



Fraunhofer

IWS



Dresden



FRAUNHOFER INSTITUTE FOR MATERIAL AND BEAM TECHNOLOGY IWS

ANNUAL REPORT

2014

www.iws.fraunhofer.de



ANNUAL REPORT 2014



**EXECUTIVE DIRECTOR
PROF. DR. RALF ECKHARD BEYER**



FOREWORD

"We cannot change the wind, but we can change the sails."

Aristotle

In 2014 Germany's economic situation was characterized by stability and IWS' business result was positive. The institute was able to secure the high level of external contracts (about 80 percent) which has been achieved in recent years. The IWS continues its application oriented work; more than 40 percent of the revenues originated directly from industry. The remainder of the other projects had indirect industry involvement. In 2014 IWS deployed new processes and systems in industrial manufacturing. Some companies have kindly given us permission to talk about their projects in this 2014 Annual Report.

One of this year's highlights was the installation of a Laser-Arc system at an industrial customer. This project was carried out in collaboration with a partner company in Dresden. IWS developed the Laser-Arc technology to apply diamond-like coatings for wear reduction. A particular feature of these coatings is their extremely low friction coefficient, which ultimately reduces energy consumption.

IWS engineers succeeded in improving the efficiency of transformers, electromotors and generators by tailoring the magnetic flux in electrical sheets. Another exceptional result was accomplished in the area of battery development. The cycle stability was markedly increased for lithium sulfur-batteries and also for the less costly sodium-sulfur batteries, which are used in stationary applications.

The IWS also works intensively on significant future topics such as additive manufacturing and Industry 4.0. Foci are component generation and sensor technologies. Sensors are a key element of the concepts in Industry 4.0.

IWS engages in many efforts. To even further increase the visibility of our efforts we have bundled our knowhow in competence centers. Internationally outstanding are:

- the center for joining technology – tailored joining,
- the center for battery technology,
- the center for energy efficiency and
- the center for additive manufacturing and printing.

Various works performed within these competence fields are presented in this Annual Report.

To express it with the words of Andreas Tenzer: "Success means moving the potential in the right direction."

The IWS is moving and we are optimistically looking forward to 2015.

Prof. Dr. E. Beyer

CONTENTS

THE FRAUNHOFER IWS

FOREWORD	3
CONTENTS	4
HIGHLIGHTS	6
FROM THE BOARD OF TRUSTEES	10
INSTITUTE PROFILE	12

BUSINESS UNITS

JOINING	20
JOINING TECHNOLOGIES FOR METALLIC AND NON-METALLIC MATERIALS	
THERMAL COATING AND ADDITIVE MANUFACTURING	42
SYMBIOSIS OF COATING TECHNOLOGY AND MATERIALS SCIENCE	
SURFACE TECHNOLOGY	56
HOLISTIC APPROACH TO MATERIALS, PROCESSES AND SYSTEMS	
ABLATION AND CUTTING	68
THE LASER TOOL FOR CUTTING AND MICROMACHINING	
PVD VACUUM COATING TECHNOLOGY	88
NOVEL COATING SYSTEMS EXPAND THE APPLICATION SPECTRUM	
CHEMICAL SURFACE AND REACTION TECHNOLOGY	106
NEW TECHNOLOGIES IMPROVE SURFACE FUNCTIONALITY	



CENTERS, NETWORKS, AWARDS

CENTERS	122
TAILORED JOINING	124
BATTERY RESEARCH	125
ENERGY EFFICIENCY	126
ADDITIVE MANUFACTURING	127
NANOTECHNOLOGY	128
NANOTUBES AND NANOPARTICLES	129
CARBONTECHNOLOGY	130
FIBER COMPOSITE TECHNOLOGY	131
LASER INTEGRATION	132
PROCESS MONITORING AND SENSOR TECHNOLOGY	133
DATA MANAGEMENT	134
MEDICAL AND BIOSYSTEMS ENGINEERING	135
DORTMUNDER OBERFLÄCHENCENTRUM (DOC®)	136
LASER INTEGRATED MANUFACTURING IN WROCŁAW (PCW)	138
COATINGS AND LASER APPLICATIONS (CCL)	140
NETWORKS	142
THE FRAUNHOFER-GESELLSCHAFT	143
FRAUNHOFER-GROUP LIGHT & SURFACES	144
EXCELLENT COOPERATION PARTNER: TU DRESDEN	146
SPECIAL EVENTS	148
AWARDS AND HONORS	150
PUBLICATIONS	152
ADDRESS AND DIRECTONS	158
IMPRINT	159

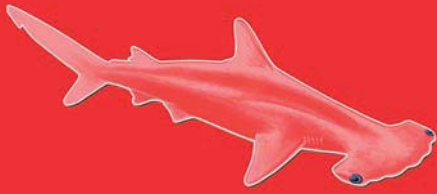

AEROSPACE RESEARCH AT FRAUNHOFER IWS

Laser beam welding of airplane fuselage structures has long been a research subject in Fraunhofer IWS business unit "Joining". In close cooperation with the Airbus Group the process has matured throughout the years to a level of industrial readiness. The next development phase focuses on the implementation of friction stir welding processes to join large and limp 3D hull sections. This technology requires a new system concept involving intelligent clamping fixtures. The Fraunhofer IWS in Dresden participates in the aerospace research programs IV and V under which the new machine concept is being developed. The concept encompasses fixtures, positioning, milling and friction stir welding processes to join the large and limp hull sections in a single machine setup (pages 30/31).

EFFICIENTLY WELDING THICK SHEETS

Many high tech applications depend on components made from thick sheet metal. Often the welding of such sheets is challenging and has become a major factor contributing to manufacturing costs. The Fraunhofer Institut für Werkstoff- und Strahltechnik, IWS Dresden, has developed a new welding process for metal sheets as thick as 50 mm. The process was developed with the goal to reduce manufacturing costs. The new VDI funded project "SIGEFILAS - New processes to overcome technical limitations of laser beam deep-welding of aluminum lightweight construction alloys" aims at applying the existing know-how to aluminum alloys of up to 200 mm sheet thickness.

BATTERY RESEARCH MOVES INTO NEW FACILITIES

In the spring of 2014 the Fraunhofer IWS acquired new laboratory space as part of the third construction phase on campus. Since then all research activities on new battery

materials and related manufacturing technologies have been concentrated in a single location. IWS research focuses on lithium-sulfur and sodium-sulfur batteries. Substantial progress was made in the area of material development. A new strategic project LiScell was started in 2014 to further ramp up development work in this technology field.

ADDITIVE MANUFACTURING LAUNCHED WITH THE STRATEGIC PROJECT AGENT-3D

Led by Fraunhofer IWS, more than fifty partners aim to transform additive manufacturing into a key technology. The Federal Ministry of Education and Research invests 45 million Euros to support the 3D revolution of product manufacturing in the digital age. In 2014 Fraunhofer IWS and other Fraunhofer institutes collaborated in a strategic project to lay the foundation for following technology projects starting in 2015. The results and novelties in the field of generating will be presented at the International Symposium Additive Manufacturing ISAM on February 26th and 27th 2015, in Dresden (www.iws.fraunhofer.de/isam).

FIRST STAGE BUILDOUT ACCOMPLISHED OF THE CENTER FOR RESOURCE-SAVING ENERGY TECHNOLOGIES - RESET

The fourth construction phase of the Fraunhofer research campus was completed near the end of 2014. Over the coming months the Fraunhofer institutes IWS and FEP will establish a Center for Resource-Saving Energy Technologies. One of the IWS operated laboratory sections is about 500 m². This laboratory will house additive manufacturing technology to continuously generate objects with powder or wire materials. Additional installations will include powder-bed based processes and analytics. The second IWS laboratory in the new building will house combined technologies for constructive and structural lightweight fabrication. Here IWS expands its competencies in polymer-metal joining and fiber composite materials.



FIRST INDUSTRY IMPLEMENTATION OF LASER MAGNETIC DOMAIN REFINEMENT WITH THE HELP OF FIBER LASERS

IWS collaborated with its industrial partners Rofin-Sinar Laser GmbH and Karl H. Arnold Maschinenfabrik GmbH & Co.KG to implement a fiber laser based process improving the properties of grain-oriented magnetic sheet steel. These electrical sheets are manufactured at an overseas customer for the purpose of building transformers. The “laser magnetic domain refinement” process markedly reduced transformer losses. The fiber laser treatment reduces such losses by up to 15 % compared to the untreated sheet metal. CO₂ laser processes achieve a reduction of about 10 %. The current system concept combines four fiber lasers with 3 kW each replacing the CO₂ lasers, which simplifies the system concept.

SUSPENSION DELIVERY SYSTEM FOR THERMAL SPRAYING

Suspension spraying is a new thermal spray technology that makes the deposition of coatings possible with a wide range of properties such as variable thicknesses and morphologies and properties. Partnering with GTV Verschleisschutz GmbH yielded a delivery system for aqueous solutions containing the spraying additives. This suspension feeder has a set of two separate pressure vessels. One vessel contains the suspension with the spraying additive and the other holds a cleaning fluid. The suspension is delivered to the spray gun by pressurizing the vessel, which guarantees a continuous delivery of the fluid free of pulsations. After finishing, the deposition process follows a rinse cycle.

The suspension feeder can be directly fitted to an already existing spraying machine and provides long-term stable spraying capabilities. Performing atmospheric plasma spray and novel gas driven high velocity flame spray processes validated the system. The International Thermal Spray Conference 2014 in Barcelona was used as a platform to first publicly present this technology. Fraunhofer received much resonance, and GTV meanwhile sold several systems to international customers.

ADDITIONAL INDUSTRIAL IMPLEMENTATIONS OF REMOTE CUTTING TECHNOLOGY FOR AIRBAG FABRICS

The Fraunhofer IWS and Held Systems have developed a compact and flexible system to laser cut airbag material. In 2014 two additional customers in Romania and Mexico received their systems. These were the 13th and 14th installations of IWS developed laser remote technology to cut single and multilayer fabrics with high productivity.

WEAR RESISTANCE DUE TO LASER-ARC MODULE

Super hard amorphous carbon coatings (Diamor®) for tools and components are deposited using IWS developed LAM500 technology. Another system was delivered to industry partner Vakuumtechnik Dresden (VTD). This system will be installed at an end user in Russia to coat various components with friction reducing ta-C coatings.

2014 HIGHLIGHTS



COATING ANALYSIS USING SOUND WAVES

In 2014 a LAwave® measurement system was delivered to Zholdau L.L.C., Kazakhstan, providing the capability to measure the properties of nanometer thin films.

MEASUREMENT AND CONTROL SYSTEMS FOR INDUSTRIAL LASER MATERIAL PROCESSING

In 2014 several E-MAqS® temperature measurement systems and the corresponding LompocPro software were delivered to customers for industrial laser materials processing applications. IWS and ALOtec Dresden GmbH integrated this control system for the first time into 4 mobile laser beam hardening systems. The mobile application is to perform on-site hardening on very large parts; impossible in the past.

These control systems were also used for the first time to selectively monitor laser buildup welding or laser hardening processes. The systems were integrated into 8 milling centers of the industry partner Sauer GmbH / DMG MORI. This concept enables the customer to explore completely new market segments that have enormous development potential. Integrating temperature controlled laser buildup welding and hardening in a milling center creates a very efficient and shortened process chain in a market that is dominated by high volume and small part manufacturing. The delivered technology package included the control system as well as powder nozzles and a process for buildup welding and generating at DMG Sauer. In addition IWS scientists performed training sessions for operators and sales personnel.

COATING OF LARGE PARTS

Fraunhofer IWS collaborated with its industrial partner GTV Verschleisschutz GmbH to deliver a large machine providing surface coatings to parts used in energy generation. The customer is NAMRC in Sheffield, UK. The machine performs high power laser buildup welding processes with a 15 kW laser and offers a working space of 10 x 10 x 5 m³. IWS provided the powder nozzle COAXpowerline, the broad jet head COAX11, the DCAM offline programming software package and a high performance coating process for nickel super alloys. NAMRC uses the machine to coat parts of up to 1000 kg with a deposition rate of up to 12 kg/h.



FROM THE BOARD OF TRUSTEES



The Board of Trustees consults and supports the institute's management and the bodies of the Fraunhofer-Gesellschaft. The 24th Board of Trustees meeting occurred on March 21st, 2014 at the Fraunhofer IWS in Dresden. The following members were active in the Board of Trustees during the reporting period:

FRANK JUNKER, DR.

Chairman of the Board of Trustees,
Independent Consultant,
Radebeul

REINHOLD ACHATZ, DR.

Manager Corporate Technology, Innovation & Quality,
ThyssenKrupp AG,
Essen

DIETER FISCHER

Chief Executive Officer,
EMAG Leipzig Manufacturing Systems GmbH,
Leipzig

PETER KÖSSLER

Plant Manager Ingolstadt AUDI AG,
Ingolstadt

UWE KRAUSE, DR.

Karlsruhe Institute of Technology,
Project Management Agency Karlsruhe,
Production and Manufacturing Technologies,
Branch Office Dresden

HANS MÜLLER-STEINHAGEN, PROF. DR.

Rector (President), Technische Universität Dresden

PETER G. NOTHNAGEL

Chief Executive Officer,
Saxony Economic Development Corporation GmbH,
Dresden

MARKUS RALL, DR.

Chief Executive Officer,
Adolf Mohr Machine Factory GmbH & Co. KG,
Hofheim/Taunus

HERMANN RIEHL, MINR

Federal Ministry of Education and Research,
Head of Department Production Systems and Technologies,
Bonn

CHRISTOPH ULLMANN, DR.

Chief Executive Officer,
Laserline GmbH,
Mühlheim-Kärlich

RENÉ UMLAUFT, DR.

Speaker of the Board of Directors, MAN Diesel & Turbo SE,
Augsburg (05/2014)

FRANZ-JOSEF WETZEL, DR.

BMW Motorrad,
Munich

PETER WIRTH, DR.

Guest of honor
Rofin-Sinar Laser GmbH,
Hamburg

REINHARD ZIMMERMANN, MINR DR.

Head of Unit Principle Affairs, Division: Research
Saxony State Ministry of Science and the Arts,
Dresden



In 2014 we enjoyed a strong economy. Some “clouds” appeared during the middle of the year, however, the fourth quarter delivered a positive surprise showing overall cautious but good developments. Two reasons are often cited:

- a slightly improved world economy and
- the lower Euro exchange rate.

Some people had concerns about the crisis in the Ukraine and Russia, however, the effects on the German economy are not yet clearly visible. The federal government expects a “black zero” (flat to minimal) for economic growth. This would be the first time since 1969 and may lead to the allocation of ten billion Euros for investments. A promising proposal from the BDI industrial association are taxpayer funded research and development investments. Considering the current figures and innovations Germany's economy is solidly positioned.

The Fraunhofer-Gesellschaft with its applied research institutes and the best possible research offer is clearly focused on industry.

The Fraunhofer Institut für Werkstoff- und Strahltechnik IWS continued in 2014 to deliver a high level of scientific performance. The scientific and economic research results follow the goals of innovation, excellence and economic efficiency. The institute pursues challenging scientific areas and has a clear focus on user benefits, which places IWS in a very good position for the future.

IWS remote locations in the USA and project partners in Poland contribute to the successful international orientation of the institute.

The DRESDEN-concept collaboration with the Technische Universität Dresden, the Max-Planck Institutes, the Leibniz Institutes and the Helmholtz Center promotes Dresden as a scientific location with much young talent.

The Board of Trustees carefully follows the positive development of the IWS and supports the institute's strategic orientation. We thank our customers, the employees, the management and all partners for the collaboration, the achieved results and your engagement. We wish you continuing success for the future.

Sincerely yours

Dr. Frank Junker

INSTITUTE PROFILE

CORE COMPETENCES

The transfer of current research results into industrial practice is an essential driving force for research efforts at the institute. To adequately meet this "mission" we have developed and continually expanded core competences in the following areas:

LASER MATERIALS PROCESSING

- high speed cutting of metals
- cutting and welding of plastics and other non-metals
- welding processes for hard-to-weld materials
- laser buildup welding
- additive manufacturing
- laser surface hardening, remelting and alloying in particular for highly stressed and complex components
- rapid heat treatments
- laser hybrid technologies, e.g.
 - laser induction welding and buildup welding
 - plasma, TIG or MIG assisted laser beam welding and buildup welding
- ablation, cleaning and structuring
- process specific monitoring and control

SURFACE FUNCTIONALIZATION AND COATING

- plasma, arc and flame spray processes with powder and suspensions
- high rate coating processes (vacuum arc, electron beam evaporation)
- laser arc process as a hybrid technology
- plasma and chemical etching, ablation, cleaning
- chemical vapor deposition
- paste deposition (also in roll-to-roll process)
- spray deposition of ultrathin coatings
- nano and micro structuring

SYSTEMS TECHNOLOGY

- implementation of process know-how in development, design and fabrication of components, machines and systems including associated software
- systems solutions for cutting, welding, ablation, deposition, surface refinement and characterization with laser, e.g.
 - processing optics, sensorics, beam scanning and monitoring systems including control software for high speed and precision processing
 - beam shaping systems and process control for surface refinement with high power diode lasers
- coating heads for the continuous free-directional powder or wire delivery as well as process monitoring and CAM control software
- process oriented prototype development of components and coating systems for the PVD precision and high rate deposition, the atmospheric pressure CVD as well as chemical and thermal surface refinement processes
- measurement systems for coating characterization, nondestructive component evaluation with laser acoustic and spectroscopic methods
- systems for the spectroscopic monitoring of gas mixtures
- software and control technology

"Success is having exactly the right skills in the right moment."
Henry Ford



MATERIALS SCIENCE / NANOTECHNOLOGY

- determination of material data for material selection, component design and quality assurance
- metallographic, electron microscopic and microanalytical characterization of the structure of metals, ceramics and coating compounds
- failure and damage analysis
- thermal shock characterization of high temperature materials
- property evaluation of surface treated, coated and welded materials and components
- optical spectroscopic characterization of surfaces and coatings (nm through mm)
- mechanical and tribological characterization
- coating thickness and Young's modulus measurements of nm to mm coatings with laser acoustics
- ellipsometry, X-ray reflectometry and diffractometry
- imaging surface analysis
- electrochemistry and electrode chemistry
- fabrication, functionalization and processing of nanoparticles and nanotubes

SPECIAL JOINING TECHNOLOGIES

- electro magnetic pulse welding
- 3D friction-stir welding
- adhesive bonding, including laser cleaning and rapid hardening

PROCESS SIMULATION

- in-house development of simulation modules for
 - thermal surface treatments and laser hardening
 - laser powder buildup welding
 - vacuum arc deposition
 - laser cutting and welding
- calculation of optical properties of nanocoatings with internal simulation tools
- use of commercial simulation modules for
 - laser beam welding and cutting
 - optimization of gas and plasma flows during coating processes and laser materials processing

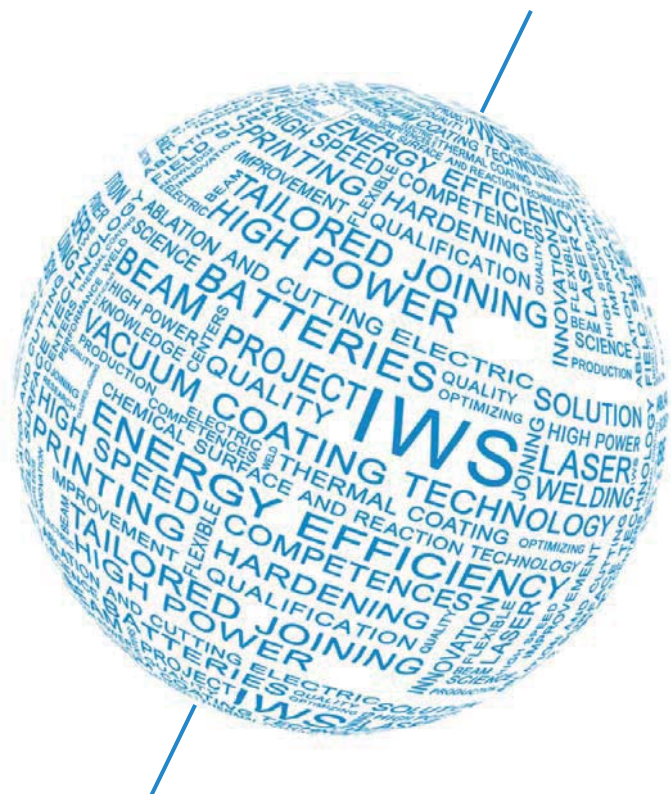

**DEPUTY DIRECTOR
DR. ANJA TECHEL**



"An idea not capable of realization is an empty soap bubble."
 Berthold Auerbach

INSTITUTE DATA

IWS EMPLOYEES

	number
Staff	199
Scientists / Engineers (TU/FH)	143
Skilled workers with technical or mercantile education	48
Trainees	8
TU Dresden employees (working at the IWS)	48
Scholarship holders and external colleagues	9
Research assistants	210
TOTAL	466

IWS PUBLICATIONS

	number
Dissertations	2
Diploma theses	18
Master's theses	8
Journal papers	89
TOTAL	117
Patents (first filing)	18

43 % Staff

10 % TU employees

2 % Scholarship holders and external colleagues

45 % Research assistants

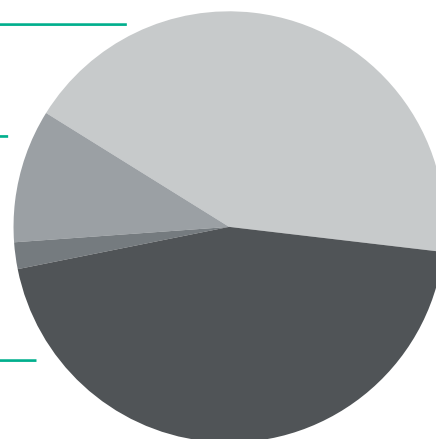

EMPLOYEES AT THE FRAUNHOFER CCL (USA) 21

Revenues 2014 (Mio. €)*	Operation	Investments	Total
Project revenues from industry	10.4	0.2	10.6
Project revenues from federal, state and European sources	7.9	0.3	8.2
Base funding and Fraunhofer internal programs	5.8	2.4	8.2
	24.1	2.9	27.0

Expenditures 2014 (Mio. €)*	
Personnel costs	12.6
Material costs	11.5
Investments	2.9
	27.0

Fraunhofer industry $\rho_{Ind} = 43.8 \%$

*JANUARY 2015

GEOGRAPHICAL ORIGIN OF INDUSTRIAL REVENUES

Germany 80 %

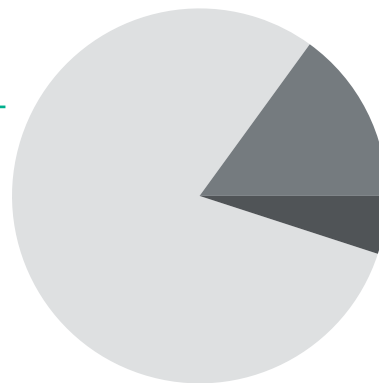

Europe 15 %

Asia 5 %

ORIGIN OF REVENUES FROM FEDERAL, STATE AND EUROPEAN SOURCES

BMBF 35 %

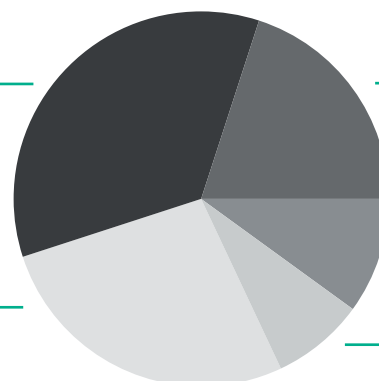

State 20 %

EU 10 %

Governmental agencies 27 %
(BMBF excluded)

Other 8 %

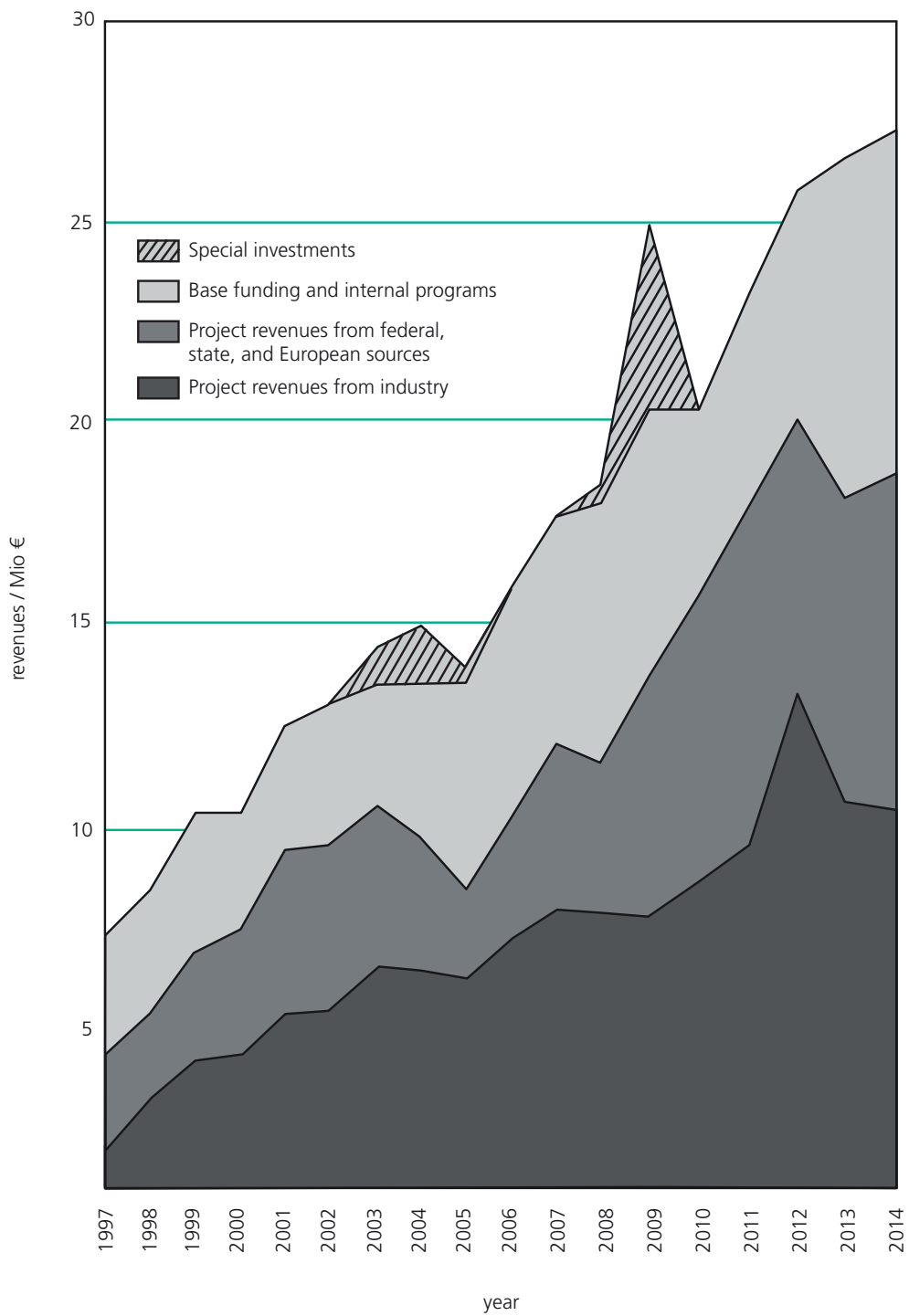

*"There will always be a frontier where there is an open mind
and a willing hand."*

Charles Kettering

THE MANAGEMENT TEAM



ORGANIZATION AND CONTACTS

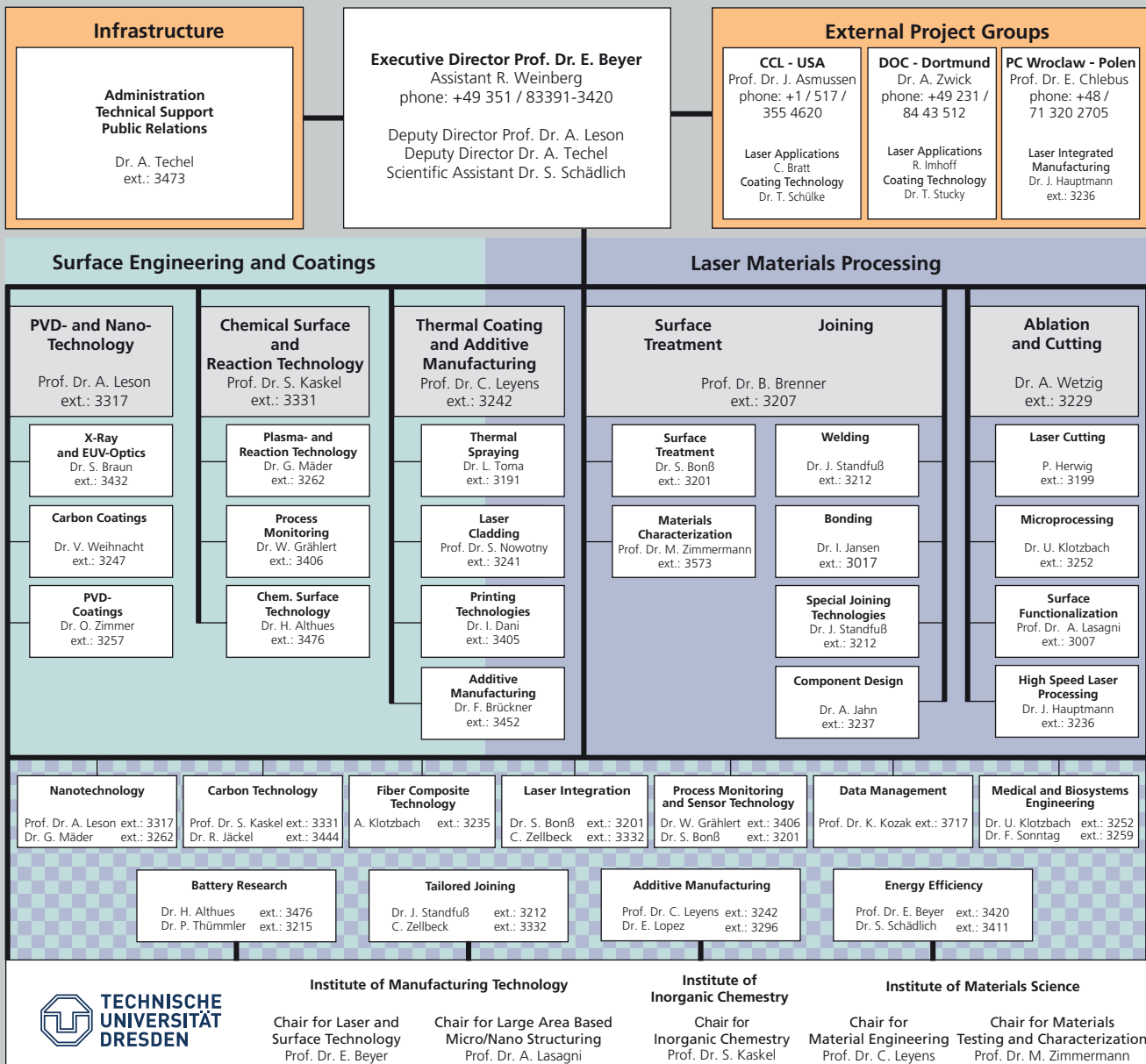

**HEAD OF DEPARTMENT
PROF. DR. BERNDT BRENNER**



"Those who reach no further than they can, always remain below their possibilities."

Herbert Marcuse



BUSINESS UNIT JOINING

Editor: In recent interviews we have frequently discussed the joining of mixed materials. How do you rate this topic today?

Prof. Brenner: The needs for cost-efficient lightweight construction, saving of material resources and mixed material designs have become even more important. We are experiencing an increasing industrial demand in these areas. At the same time only a few technologies have been thoroughly researched in their complexity or have found their way to industrial manufacturing. We will continue to deliver results based on customer requests and we will further expand our portfolio of joining technologies (pages 24-41) as well as finding opportunities to deploy them in industry. Synergies are emerging as we serve different industrial branches such as the automotive and aerospace industries, manufacturers of railroad vehicles, semi-finished products and other suppliers. Technologies such as the double-sided simultaneous welding of T-joints have been developed for the aerospace industry but these processes and systems can also be used in other industries. One example is the welding of lightweight sidewalls in trams (pages 28/29).

Editor: How far has the development of novel joining processes progressed?

Prof. Brenner: The development of joining processes so far without existing industrial system solutions requires novel and process tailored systems technology. Therefore we have started work on system solutions and special concepts for joining processes. An exceptional example is the so-called MUVAX system. This unique solution is designed to join large limp 3D aluminum parts. It replaces extremely large and stiff

machines that were based on 5-axes systems. With this new technology we expand our activities in developing joining technologies for aerospace fuselage structures to also handle 3D-shaped panel sections. This represents a new development step for the assembly of large components of airplane fuselage structures.

Editor: What are your future development goals for laser-based multi-pass narrow gap welding processes?

Prof. Brenner: Laser-based multi-pass narrow gap welding is a very promising technology to overcome the limits of conventional laser welding processes. This is especially true for hard-to-weld materials. Our development efforts aim at increasing efficiencies and welding depths. The goal is to deep-weld material combinations, which are very difficult to join. So far we have achieved a welding depth of 50 mm in precipitation-hardenable aluminum alloys. We continue to work on naturally hardened alloys in a project funded by VDI-TZ Düsseldorf. A Fraunhofer internal project aims at welding depths of 100-200 mm in nickel super alloys to meet the needs of industrial high technology branches. For thin sheet metal joining we are increasingly employing new technologies such as web-slot connections. This approach allows us to efficiently join more material combinations including Al/steel, Al/Cu and Al/CFC. The mechanical strength of such joints substantially exceeds that of riveted connections.



COMPETENCES

WELDING OF HARD-TO-WELD MATERIALS

Laser welding is a broadly established manufacturing technology; particularly for high volume production. Laser welding processes are available with integrated short-term heat treatment, with specially adapted filler materials and with high frequency beam manipulation. Such process capabilities facilitates a new approach to welding crack free joints in hardenable and high strength steels, cast iron, aluminum and special alloys, hot crack sensitive alloys and components with high stiffness. The group has a strong background in systems as well as in metal physics, and its offer includes the development of welding technologies, prototype welding, process and system optimization and the development of welding instructions.

SURFACE CONDITIONING AND CONSTRUCTIVE ADHESIVE BONDING

Plasma and laser surface conditioning is frequently used to prepare surfaces for better wetting behavior for adhesives, which ultimately results in higher bond strengths. Contact angle, roughness and coating thickness measurements are used to characterize such surfaces and adhesive bonds. Optical microscopy, SEM/EDC and spectroscopic methods are applied as well. The integration of carbon nanotubes into adhesives can increase the bond strength and also makes the adhesive bond electrically conductive. The group offers conditioning processes and characterization of surfaces used in adhesive bonding. Constructive adhesive bonding is offered for various materials. Bond strength measurements and ageing studies can be performed. Consulting is offered on all topics of adhesive bonding.

SPECIAL JOINING PROCESSES

Conventional standard melt based welding processes often reach their limitations when it comes to welding of modern functional materials. For metals, this is for example the case for welding high strength aluminum alloys. The problem is even more critical when a joint is desired between different metals such as aluminum and copper. In such a case the melt during the welding process forms intermetallic phases, which severely reduce the mechanical strength of the joint. The group therefore focuses on developing joining processes that do not require melting the materials and thus avoid the associated problems. The primary focus is on friction stir welding, laser beam soldering, laser induction roll plating, and electromagnetic pulse welding. The offer includes process development, prototype welding and systems development.

COMPONENT DESIGN

The combination of increasing application requirements for components, the use of innovative materials and of new manufacturing processes, usually also demands new component design approaches. The group supports the customer to successfully implement Fraunhofer IWS developed joining and heat treatment technologies by offering structural mechanical FE simulations, thermo-mechanical calculations as well as experimental verification. The goal is to tailor and optimize the component design to best suit the customer's processing and application specifications and load conditions. Such solutions are closely connected with process development and materials characterization.



**GROUP LEADER
WELDING**

DR. JENS STANDFUSS
phone +49 351 83391-3212
jens.standfuss@iws.fraunhofer.de



**GROUP LEADER
BONDING**

DR. IRENE JANSEN
phone +49 351 83391-3017
irene.jansen@iws.fraunhofer.de



**GROUP LEADER
SPECIAL JOINING TECHNOLOGIES**

DR. JENS STANDFUSS
phone +49 351 83391-3212
jens.standfuss@iws.fraunhofer.de



**GROUP LEADER
COMPONENT DESIGN**

DR. AXEL JAHN
phone +49 351 83391-3237
axel.jahn@iws.fraunhofer.de



**HEAD OF DEPARTMENT
PROF. BERNDT BRENNER**

phone +49 351 83391-3207
berndt.brenner@iws.fraunhofer.de



2014 PROJECT EXAMPLES

- | | |
|--|----|
| 1. Roll plated Al-Cu joints – ductile and high strength | 24 |
| 2. Fabricating steel-aluminum hybrid sheets suitable for forming | 26 |
| 3. Laser beam welded lightweight sidewalls for railroad vehicles | 28 |
| 4. New joining technologies for future fuselage metal structures | 30 |
| 5. Adhesive bonding of metal conductors to transfer electric energy | 32 |
| 6. Magnetic pulse welding – a new joining process with potential | 34 |
| 7. Laser MSG hybrid welding of mobile crane booms | 36 |
| 8. Laser multi-pass narrow gap (MPNG) welding of aluminum alloys of up to 50 mm thick sheets | 38 |
| 9. Joining of metal foams for energy storage devices | 40 |



ROLL PLATED AL-CU JOINTS – DUCTILE AND HIGH STRENGTH

THE TASK

In vehicle electric engineering copper is the established material for electronic components. Despite the fact that the price for copper is three times that of aluminum, most of the connectors in cars are made from copper or copper alloys. This nonferrous metal contributes substantially to the overall weight of the vehicles.

In recent years the requirements to reduce CO₂ emissions have led to steadily reducing vehicle weights. This trend affects electrical components as well. With respect to weight, aluminum is the better conductor and it is also less costly. A future trend will be to replace copper wiring with aluminum in car electrics.

Connecting an electrical component with copper to an aluminum wire requires low contact resistances as well as some way to prevent the creeping of aluminum. This can be accomplished by welding the connections. However, welding copper and aluminum using melt-based processes forms brittle phases in the material joint, which reduce the strength of the connection.

This situation requires a better solution to connect aluminum with copper.

OUR SOLUTION

Our solution is to use semi-finished Al/Cu parts. They can directly connect the Al/Cu bimetal or they can be inserted as a coupling transition joint.

Engineers at the Fraunhofer IWS Dresden collaborated with an industrial partner to develop a roll plating process, which enables the joining of hard-to-weld material combinations including aluminum and copper. Laser radiation is applied to heat the facing surfaces to the temperature required for joining. This heat occurs directly in front of the roll gap. Thus the heat deformation is limited to the surface region near the joining zone.

Aluminum and copper behave differently under deformation. This leads to a different material flow at the transition between the metals. These differences in material flow suppress the local stoichiometry required to form brittle phases. Subsequently there are no or only minor brittle phases developing near the joint. These occur close to the interface of the aluminum side in the mixed crystal. Roll plating fabricates high-strength material compounds capable of being cold formed.



2

RESULTS

Fraunhofer IWS' laser roll-plating machine is designed to join material strips. Fig. 1 shows the principle of the plating process and the arrangement of typical machine components. The two metal strips to be joined are fed at angles of 45° toward the gap where they meet up to be roll plated together. When passing the laser focus line, the surfaces of both strips are heated to the necessary temperature just prior to running into the roll-plating gap.

The machine also integrates high frequency generators, which heat both strips to affect the forming behavior and to accelerate the plating process. During the process the heated strip sections and the roll plating gap are flushed with protective gas to suppress oxidation.

Additional system components include the strip reels, fixtures and brushes to clean the surfaces prior to joining. The system integrates an 8 kW disk laser. It is also possible to use other or multiple lasers. The width of the line focus is adjusted via special optical components.

Typical for this process is a very localized energy deposition and deformation. Therefore the overall distortions are minimal and yet the process yields a high strength material compound. The process is suitable for near net shape plating and also allows for a wider range of strip thickness combinations compared to conventional roll-plating processes.

The possible width of the strips to be joined depends on the available laser power. Fig. 2 shows some typical semi-finished products coming out of this process. The joints are of very high strength and can be cold formed up to 90° off the original orientation of the plating plane. This way it is possible to fabricate very thin butt joints for example for transition joints.

- 1 *Laser roll-plating machine, region in front of the rolling groove*
- 2 *Semi-finished products*

CONTACT

Dipl.-Ing. Volker Fux
 phone: +49 351 83391-3243
 volker.fux@iws.fraunhofer.de



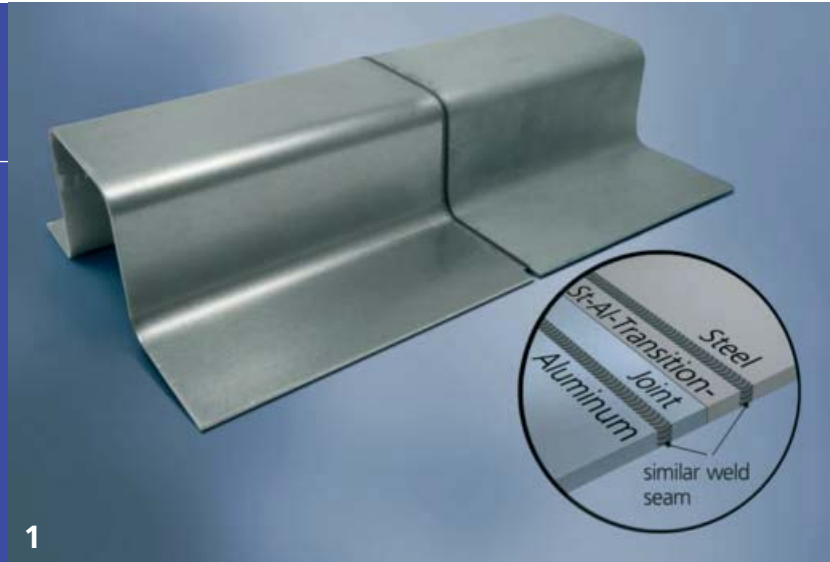

1

FABRICATING STEEL-ALUMINUM HYBRID SHEETS SUITABLE FOR FORMING

THE TASK

Lightweight construction solutions benefit from the flexibility of selecting materials that best match the desired application. The automotive industry is particularly interested in hybrid material constructions made from metals such as aluminum and steel. Thus safely bonding different materials poses a key challenge. The metals need to be firmly bonded since sheet metal components will undergo forming processes during production and final concepts are often exposed to high thermal and mechanical loads as well. Many metal combinations are hard to weld with conventional processes. Intermetallic brittle phases tend to form in the welded joints. This is undesirable since such joints are then difficult to deform, which ultimately limits the usability of the multi material sheets. The task is to develop welding processes that suppress intermetallic phase formation so that the multi-material metal sheets are suitable for subsequent forming processes. The weld has to be fabricated in a butt joint layout so that conventional forming tools can be used.

OUR SOLUTION

A two-stage process was developed to firmly bond different metals such as steel (DC04) and aluminum (AlMg₃). The first step is a laser induction roll-plating process (Fig. 2a, pages 24/25). This process creates a bimetal band of the desired material combination. Two metal strips are inductively preheated and by means of laser radiation, heated to joining temperature. Then both strips are pressed together via roll plating to bond over a large surface area. The result is a semi-finished product with little intermetallic phases that is malleable and can be subjected to forming processes. This part serves as the transition joint to connect two different metal sheets. These are laser welded whereby each metal is joined with its own kind to the transition joint (Fig. 2b, c). Such transition joints can be fabricated by many designs including overlapping and butt joints. Traditionally the joint would have to be made from more similar metals that can be joined via welding, such as in tailored blanks.

Process schematics of the fabrication of steel-aluminum hybrid sheets suitable for forming

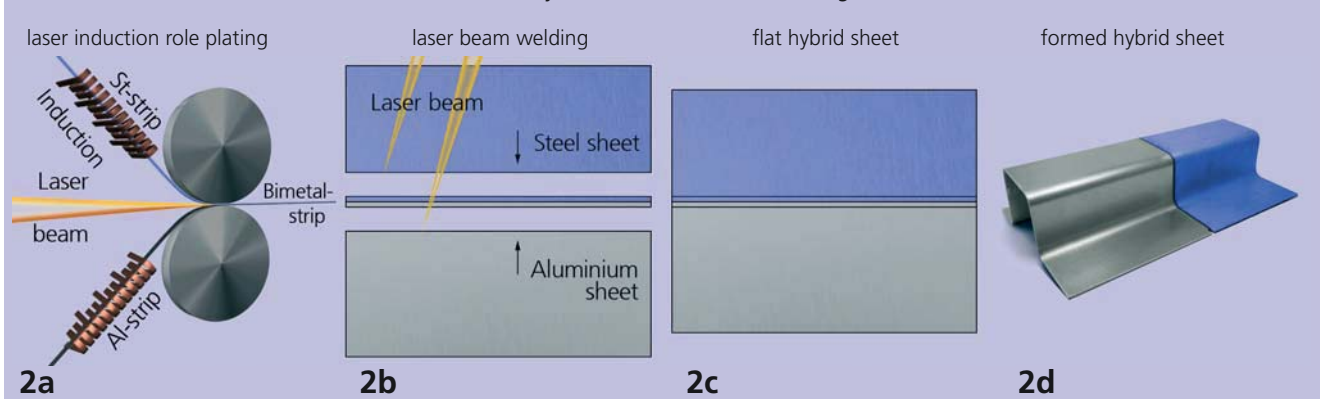



RESULTS

Several tests were performed to judge the strength and quality of the transition joints. Metallographic analysis (SEM) showed that the laser induction roll plating process forms intermetallic phases, however, this zone is less than 1 μm thick (Fig. 4). The energy input of subsequent treatments such as laser welding and cathaphoretic painting (180 $^{\circ}\text{C}$, 20 min) does not significantly influence the intermetallic joint zone. Therefore the dimensions of the zone containing intermetallic phases remain small. Such a thin seam presents a high-strength and yet ductile joint.

Polished cross sections of the joint zone in SEM (top) and microscope images (bottom)

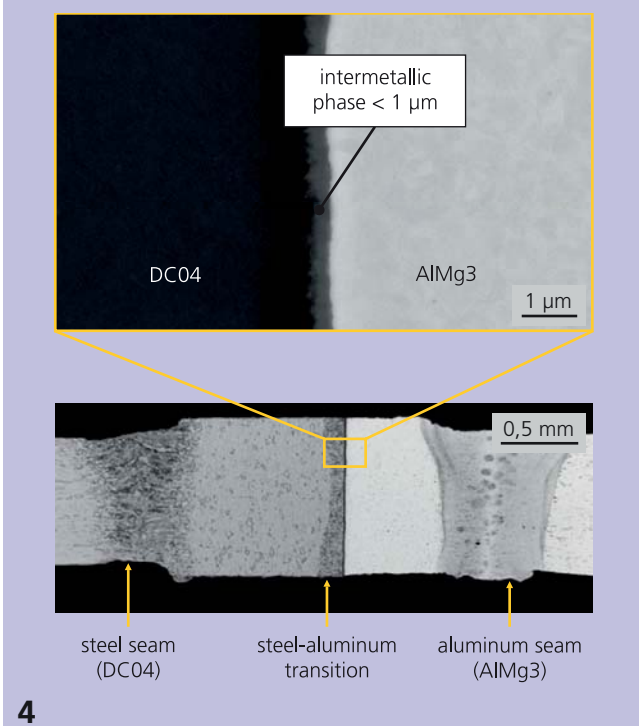

Tensile testing showed that the joint is as strong as the aluminum itself. The excellent ability to deform the joints was shown in various tests (Fig. 4). In addition, crash tests were performed with box sections made from steel and aluminum sheets. The results indicate that these multi metal constructions are well suited for vehicle structures that may experience sudden impact, such as crossbars. The multi metal construction saves 30% in weight compared to conventionally spot-welded steel sections. And yet, the increased stiffness of the structure guarantees sufficient crash safety despite the use of lightweight aluminum. Designing such structures requires knowledge about the load distribution within the components. These data were obtained via FE simulations. The techniques can also be applied to analyze the fabrication and application performance of specific customer designs. The institute offers to analyze realistic application requirements, to select the appropriate materials and to design the hybrid components. In addition we offer the development of laser induction roll plating and laser welding process as well as testing the joints.

- 1 Bent steel-aluminum hybrid sheet
- 3 Steel-aluminum deep drawing part

CONTACT

Dr. Axel Jahn
 phone: +49 351 83391-3237
 axel.jahn@iws.fraunhofer.de



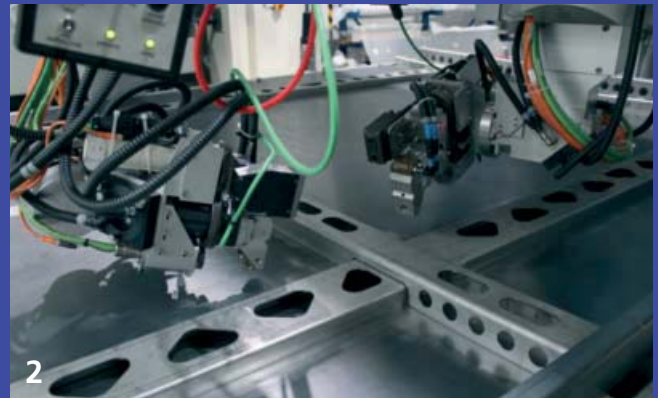

LASER BEAM WELDED LIGHTWEIGHT SIDEWALLS FOR RAILROAD VEHICLES

THE TASK

Railroad vehicles would greatly benefit from inexpensive and lighter sidewalls. The manufacturing of such sidewalls requires new designs and new manufacturing concepts. A promising lightweight manufacturing concept is the fabrication of welded and fully connected integral structures. This approach requires a highly efficient welding process with low heat impact such as offered by laser beam welding using modern brilliant beam sources. The process in combination with new sidewall designs reduces the number of individual parts, weight and manufacturing times.

Developing such a sidewall was the objective of a publicly funded project. The project partners primarily aimed at a strategy to weld the U-shaped longitudinal and horizontal stiffeners to the thin and curved outer skin panels. An actual welding experiment had to demonstrate the feasibility of this novel sidewall concept.

OUR SOLUTION

The first step was to mathematically estimate the strain that the welded joints would have to withstand under realistic conditions. The required input data were obtained from cyclic force tensile fatigue testing. The goal was to find suitable geometries for the start- and endpoints of the seams. These have to be insensitive to cyclic loading, which is a permanent condition during operation of railroad vehicles.

The efficiency of laser welding increases with seam lengths since handling and positioning times become less relevant. Therefore the sidewalls were designed to maximize seam lengths.

The actual manufacturing process consists of two steps. First the continuous longitudinal stiffeners are welded followed by welding the interrupted horizontal stiffeners. Prior to welding the stiffeners, they are tacked to the panel with high accuracy applying low laser power. The Fraunhofer IWS welding system is equipped with two DC045 CO₂ lasers. Tacking and welding can be simultaneously performed from both sides of the wall (Fig. 1 and 2). This approach reduces the risk of tilting the sections, as could occur if the welding is performed one side at a time.

Optical sensors monitor the position of the seam during the laser welding process. The welding of the longitudinal stiffeners is monitored online. The sensor runs ahead of the laser and detects intersections of stiffener section and skin panel. Geometric data analysis reveals the desired seam location to position the welding optics. Online monitoring does not work for the interrupted cross stiffener sections. Here the optical sensors detect the welding position offline. The data are first stored and then processed via NC software.

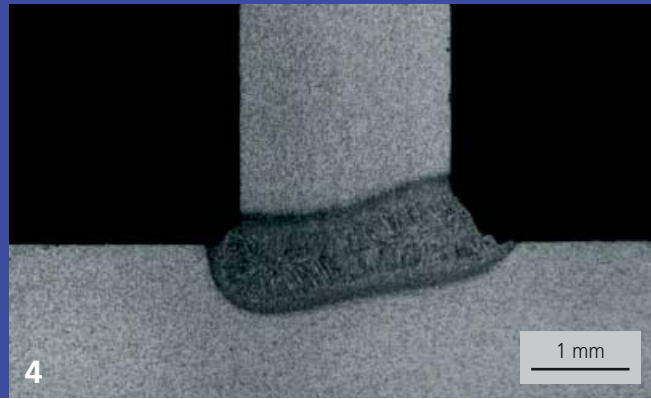
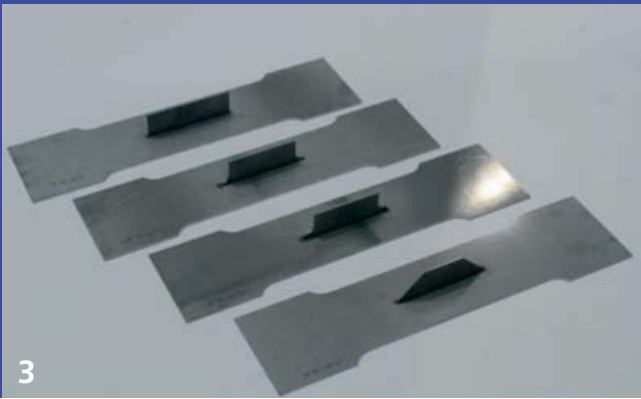

RESULTS

Samples were prepared using the welding process for longitudinal stiffeners and then subjected to fatigue testing. Steel S355 served as the reference material. Stiffener sheets were welded to flat samples aligned along the direction of fatigue strain. The stiffener panels were rectangular and trapezoidal sheets of identical overall length and height. The test sample batch with rectangular stiffeners had two additional variations with different transition radii (Fig. 3). Metal inert gas welded reference samples with rectangular stiffeners were also tested.

An important result of the fatigue test was that all laser-welded stiffeners yielded substantially higher fatigue strengths than the metal inert gas welded samples (Fig. 5).

The project also demonstrated the feasibility of building the complete sidewall structures using laser welding. The optimized design, the precision of the fabrication of the individual parts and the use of flexible fixtures allow for an almost gap-free welding of the stiffeners to the outer skin

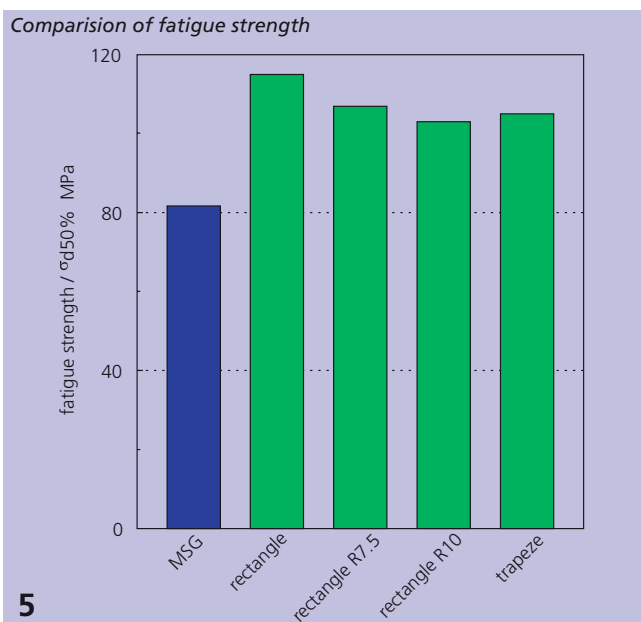

panels. Since high quality laser beam sources were used, it was not necessary to apply filler wire to close gaps during the welding process.

Based on redesigning the overall fabrication process of such sidewall structures it was possible to produce them with little distortions. The number of individual parts, the weight and the manufacturing times were reduced. Manual post-treatment is usually very expensive and time consuming. The developed process drastically reduces post-treatment requirements in series production of railroad vehicles.

The project "Segmented trams in ultra lightweight construction and structurally integrated design" was funded by Saechsische Aufbaubank (project number: 100508762).

- 1 Laser beam welded sidewall
- 2 Section of the sidewall with welding optics for cross stiffeners
- 3 Test specimen for fatigue testing
- 4 Polished cross sections of single-side welded T-joint

CONTACT

Dipl.-Ing. (FH) Jens Liebscher
 phone: +49 351 83391-3288
 jens.liebscher@iws.fraunhofer.de





NEW JOINING TECHNOLOGIES FOR FUTURE FUSELAGE METAL STRUCTURES

THE TASK

Since decades multi row riveting has been the established process to assemble fuselage metal structures. Despite the fact that this process is mostly automated, it is still expensive due to long cycle times. An additional problem is that the riveted sections have to overlap, which add unnecessary weight and material costs. This situation implies an enormous cost and weight savings potential. However, this potential can only be exploited through new joining technologies including alternative joining processes, adapted and intelligent systems and clamping fixtures. The large three-dimensional metal sheets of fuselages are floppy. Precisely positioning them for reliable processing poses particular challenges.

OUR SOLUTION

For many years Fraunhofer IWS engineers have been researching joining technologies for the aerospace industry. Friction stir welding is becoming ever more important in addition to laser beam welding for joining airplane components. As part of the Aerospace Research Program IV effort, IWS engineers have developed intelligent machine concepts to handle large and floppy three-dimensional components and join them via friction stir welding.

Friction stir welding generates enormous forces by default. Typically these forces are balanced with a support structure that is underneath the fixture holding. This approach is too costly for the aerospace industry since here the components are very large and of varying geometries. Thus each part would require its own unique large fixture and support structures. Therefore the team designed a friction stir welding process using flexible fixtures that do not require fixed counter points. The approach makes use of the so-called Bobbin-Tool or DeltaN-Tool. The tool's double shoulder design does not require additional support structures underneath the joining point (Fig. 1). Overall these tools substantially reduce the forces that have to be handled by the parts as well as the welding system.

Principle of the Bobbin-Tool

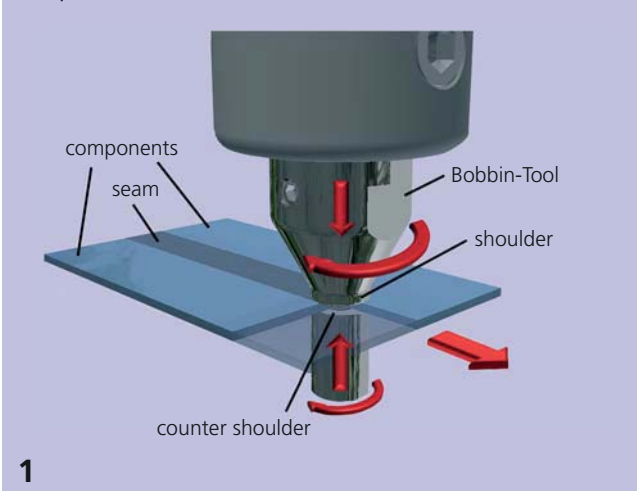

This machine concept was first implemented as a pilot system to build demonstration parts up to a size of 2.5 m .

RESULTS

The aerospace industry uses ever more non-weldable aluminum alloys. Such alloys need to be joined without melting. Friction stir welding joins materials in their solid-state phase and is therefore increasingly employed. The high forces and the solid-state phase processing form a fine-grained and thermo-mechanically reinforced seam structure. The project partners performed extensive testing of the seam quality and confirmed the extraordinary properties of such welds.

Fraunhofer IWS engineers developed a welding robot, which autonomously moves on a three-dimensional rail system using an internal drive. The system also has an intelligent clamping concept. The fixture clamps and aligns the curved parts and positions them for cutting of the joining edges as well as the actual joining processes. The required tolerances are reliably achieved.

First test samples of a fuselage were successfully welded using this new process (Fig. 3). The application of the double shoulder tool and the accompanying technical advantages avoid the need for process control.

These works were performed within the subproject "New joining technologies for future fuselage metal structures" as part of the BMWi effort ECE "Economical metal fuselage generation Best-Eco-Mix". (project number: 20W111C).

The work will be continued within the Aerospace Research Program V, subproject FUTURE II (project number: 20W1302C). The project will address new developments and optimizations of the machine concept. In particular it is planned to increase the part dimensions to 5.0 m length and to redesign the drive strategy. Achieving these goals will approach realistic airplane dimensions and geometries. Thus the result will be more valuable to judge the feasibility of the technology for future fuselage assembly.

- 2 *Passenger airplane (metal fuselage construction)*
- 3 *Friction stir welded test carrier with 3D welds, material: Al 6xxx*

CONTACT

Dipl.-Ing. Andreas Grimm
 phone: +49 351 83391-3378
 andreas.grimm@iws.fraunhofer.de



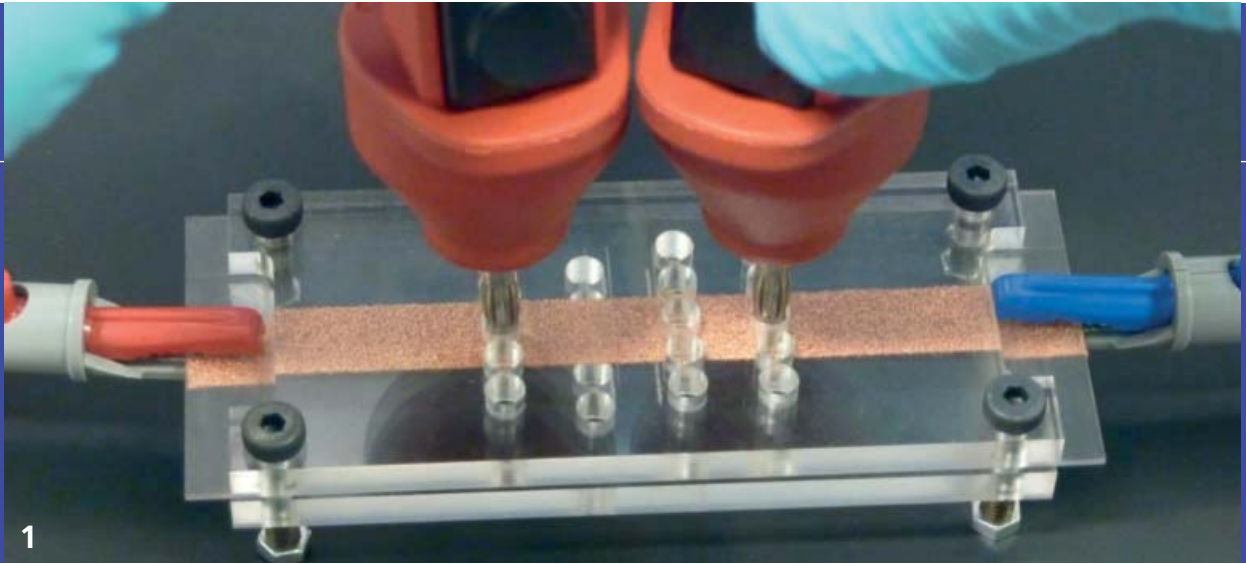

ADHESIVE BONDING OF METAL CONDUCTORS TO TRANSFER ELECTRIC ENERGY

THE TASK

The development and integration of efficient, safe and low-cost electrochemical energy storage devices is a key technology for applications in electro mobility and the use of alternative energy sources. To guarantee reliable power delivery, such devices store energy to balance strongly fluctuating electricity loads.

Typical energy storage devices consist of several cells, which are connected with each other. The contact resistance of these connectors should remain very low over the lifetime of the device to maintain device performance, safe and reliable operation.

The cells are connected in parallel. During the assembling process the anode and cathode tabs are mostly ultrasonically welded. The ultrasonic welding process introduces mechanical vibrations, which can cause "soft-shorts" between the electrodes, when parts of the active material peel off.

All known processes to fabricate and join such cell stacks require complex fixtures and positioning of the current collector plates and tabs. Solutions are sought to simplify this process and to make it more reliable for use on an industrial scale.

OUR SOLUTION

Fraunhofer IWS offers alternative solutions to achieve low contact resistances for applications where other joining methods are only of limited use due to technological or economic reasons.

The IWS process combines a custom-tailored surface treatment of the joining parts with the application of a special adhesive that is adapted to the particular application. After depositing the adhesive, pressure is applied to plastically deform the micro contacts until the adhesive is cured. The electrically conductive surface between the contacts is several times smaller than the apparent contact area. The remaining surface that did not form micro contacts is then available for adhesive bonding.

One application is the connection and fixuring of current collector foils and the tabs during the stacking process of lithium ion cells. The adhesive was selected so that it is chemically resistant to the electrolyte. The adhesive itself is electrically insulating (conductivity of $5 \cdot 10^{-12}$ S/m) and cures within seconds. The adhesive was purposely not modified by adding electrically conductive additives to avoid particle migration during charging and discharging cycles of the cells.

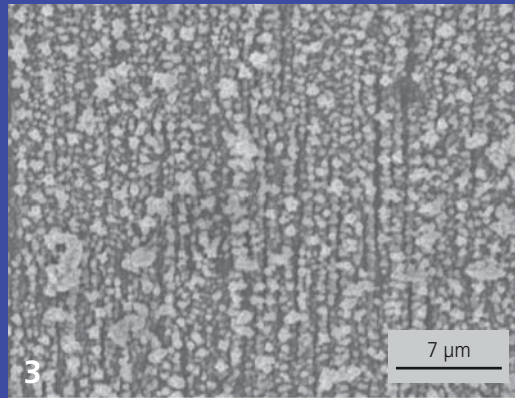
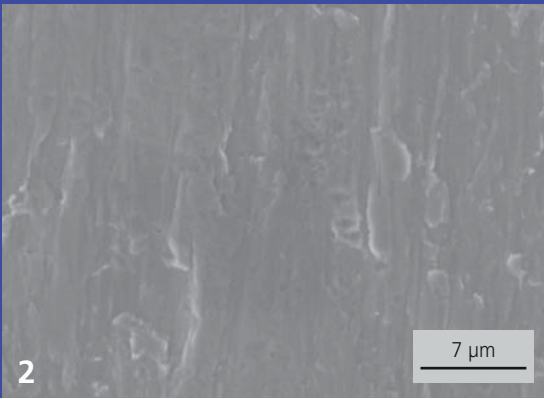

RESULTS

Adhesives are conventionally used for low current and low power contacts. The here presented method is capable to produce adhesive bonded current-carrying contacts, which meet the much higher requirements of energy power supply technologies. The total connection resistance of such adhesive bonds is a few $\mu\Omega$ and the joining process is very fast.

In addition, the method can easily join different conductor materials and geometries over a wide temperature range (e.g. from liquid nitrogen at $-196\text{ }^\circ\text{C}$ to $100\text{ }^\circ\text{C}$ and higher). The method also protects the contact surfaces from a variety of media influences.

Decisive factors to achieve low connection resistance are the selection of a suitable adhesive, the surface preparation of the contacts and the applied joining pressure. Fig. 4 shows the influence of these factors for copper anode foils, which were bonded with and without surface modification.

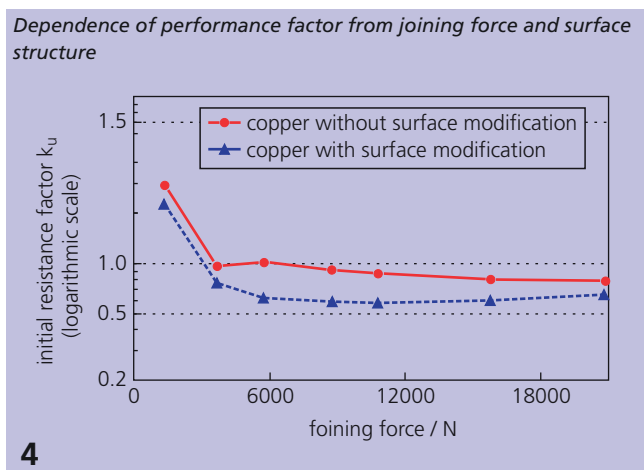

The quality of a connection is evaluated by the performance factor k_u , which allows a comparable representation of different materials and contact cross sections. This factor is the ratio of the resistance of the connection R_v measured over a length l_v to the resistance R_L of the homogenous conductor material with the same geometry and length l_L . If $k_u = 1$ then the power loss and heating over the connector is equal to the power loss over the regular metal conductor.

The results show that it is possible to achieve electrically conductive adhesive joints with a performance factor $k_u \leq 1$ when the joining force exceeds a specific threshold. When using surface-modified anode foils, the results improve further and the process window can be shifted to lower joining pressures.

This work was funded by the BMBF (BamoSa project number: 03X4637A). The IWS is grateful for support from the Chair of High Voltage Technology and High Power Engineering at the Technische Universität Dresden.

- 1 Setup for the determination of connection resistances
- 2/3 SEM images of the surface structure of a virgin (left) and a modified (right) copper foil

CONTACT

Dipl.-Ing. Maurice Langer
 phone: +49 351 83391-3852
 maurice.langer@iws.fraunhofer.de



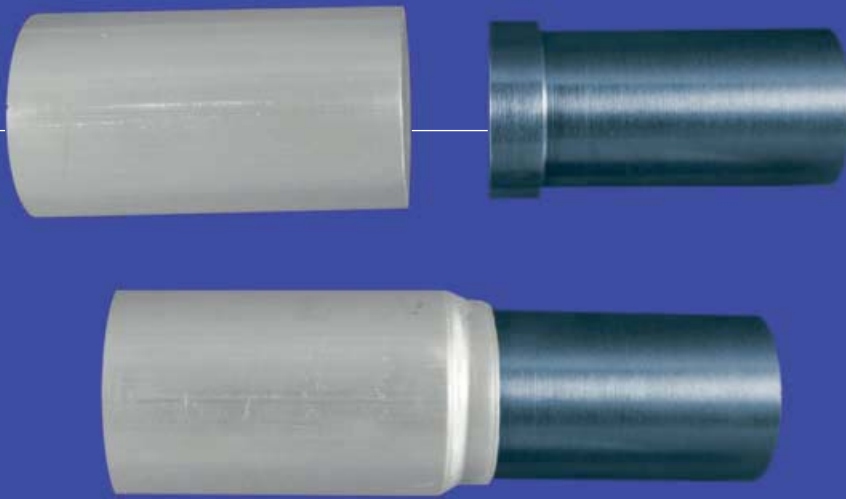

1

MAGNETIC PULSE WELDING – A NEW JOINING PROCESS WITH POTENTIAL

THE TASK

High-speed metal joining processes are increasingly important to industry. High-speed processing implies low thermal loads, which makes them especially suitable for the joining of dissimilar materials.

Magnetic pulse welding (MPW) exposes the part to a transient magnetic field resulting in strong Lorentz forces acting upon the joining region. This process has many advantages over the widely used process of explosive welding. It is a safer and contactless method. The variety of weldable parts is larger and pre- and post-processing steps are simpler. A so-called jet current builds up during the process, which cleans the surfaces from oxides and other contaminations. Collision pressures exceed one thousand MPa to firmly bond mixed metal combinations. Partial melting and the formation of brittle intermetallic phases are subdued and the resulting joints are of high mechanical strength.

Solid-state shock welding processes require accelerations, which can be applied in several ways. The process inherent ever-changing collision conditions make it difficult to achieve homogenous joining regions. However, homogeneous conditions are absolutely necessary to achieve high quality bonding. The task is to find optimal welding parameters as a function of materials and given geometries.

OUR SOLUTION

Fraunhofer IWS engineers have three machines to study magnetic pulse welding processes. A wide parameter range can be applied to identify the most suitable welding setup for a given part. The maximal charge energies of the pulse generators are 32 kJ, 40 kJ and 160 kJ. The corresponding discharge frequencies are 25 kHz, 12 kHz and 20 kHz.

The electric current rises in fractions of a second and causes a strongly changing magnetic field inside an inductive coil where a conductive tube is located with a part inside of it. Following Lenz's rule, a current is induced inside the conductive part as well. This current carries a magnetic field opposite the magnetic flux of the coil, which results in a mechanical force. This Lorentz force acts towards the coil as well as toward the part.

The deformation velocities can reach several hundreds of meters per second. The kinetic energy of the accelerated tube is sufficient to firmly bond it with a part inside of it. An important parameter is the position of the tube, which was studied in a DFG project (Priority Program 1640). The varied working length l_w denotes the axial position of the tube towards the edge of the coil.

RESULTS

The study analyzed data from numerical magnetic field simulations, velocity measurements and metallographic studies of the joining zone. Several dependencies became apparent. The energy input is important and needs to be adjusted accounting for the stiffness of the material. The working length l_w is also critical. For example, a variation of l_w for a coil of a width of 15 mm yields clear differences in the crimping behavior of the tube.

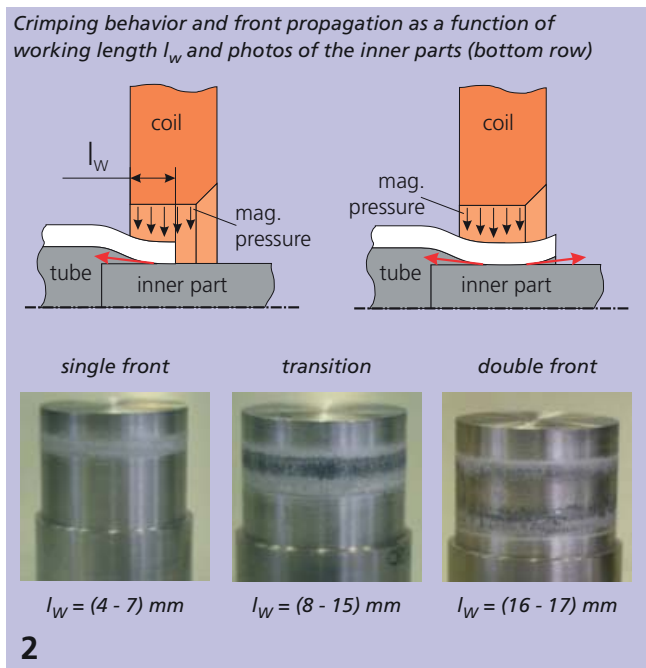

Increasing working length causes a transition from single to double front lines (Fig. 2). The red arrows show the jet current. In the transition region (middle of Fig. 2) there is no jet current since the materials collide flat. The collision front does not propagate sideways as in the other cases. This suppresses the formation of a firm bond.

The opposing propagation directions of the collision fronts can be advantageous. They reduce the risk of shearing during the crimping process. Therefore adjusting the effective length helps to tailor the process to different material combinations. This technique was used to create special joining processes for industrial applications with high requirements for leak tightness and electric conductivity.

1 *Magnetic pulse welded mixed material joint (bottom) consisting of steel and aluminum tubes*

CONTACT

M.Sc. Amanda Leigh Lorenz
 phone: +49 351 83391-3716
 amanda.leigh.lorenz@iws.fraunhofer.de





LASER MSG HYBRID WELDING OF MOBILE CRANE BOOMS

THE TASK

Mobile cranes with their telescoping booms reach lifting heights of 100 m and, with a luffing jib, extend to 195 m. They can lift up to 1200 tons (Fig.3). Driving such cranes on regular roads requires lightweight designs. Those use fine-grained structural steels of the highest strength. Fabrication tolerances have to be low and welded components have to be as flat as possible.

The core components of such cranes are the telescoping boom sections. They consist of 2 to 16 m long edged and laser-cut half shell sections with sheet thicknesses of 3 to 12 mm. The two sections are welded along their length with two seams to build a boom section. Previously this weld consisted of two layers. A root weld was performed using MSG welding. Then the top weld was done using a UP welding process. Both processes were performed on different welding machines at welding speeds of less than 0.5 m/min. The process combination also caused large warpage due to the long and thin sheets, which in turn require much time for alignment.

An IWS industry partner funded the process development to reduce warpage and alignment time without sacrificing the performance of the welded parts. A requirement was to fabricate up to 7 segments of a single boom without the need for complicated retooling and costly clamping fixtures.

OUR SOLUTION

The solution applies a fully automated single layer laser-MSG hybrid welding process. The process combines high speed and deep laser beam welding with safely supplying the molten filler material.

The technology was developed at the Fraunhofer IWS Dresden (branch Dortmund) to weld steel constructions. Welding gaps between 0 mm (for stitching) and 1 mm are typical for steel constructions, which also may require welding sheets of different thickness in butt joint or fillet weld configurations. In steel construction, instead of being milled as is common in the ship building industry, the sheet edges are laser cut instead.

The solid-state laser has 12 kW of power to weld fine-grained construction steel sheets of 3 - 15 mm (welding gap 0 - 1 mm) at speeds of 1 - 6 m/min. The sheets are welded in PC position without bath support in a single layer. The energy input of the MSG process into the part is minimized using modified pulsed arc technology.

Prior to the laser-MSG hybrid-welding, one can use an autogenous laser welding process to hand-stitch the sheets (Fig. 1). The hybrid process welds directly over the stitches.

Naturally it is also possible to weld aluminum and stainless steel sheets that are thinner than 3 mm. Single-sided fillet welds can be made as well.



RESULTS

At a customer site Fraunhofer engineers constructed a complete manufacturing plant for hybrid welding of mobile crane boom sections using the IWS process. Three laser-stitching booths are used to pre-attach the shell segments prior to applying the laser-MSG hybrid welding process. Therefore no expensive clamping fixtures are required.

A single production lot can consist of up to 7 different mobile crane boom sections. The lot is processed without changing the machine setup. The upper and lower edged section halves are up to 16 m long. By pressing them together, the local welding gap is reduced to less than 0.3 mm. Then they are stitched together using a 4 kW fiber laser with a handheld stitching head.

Polished cross section and strength values of a MSG/UP weld seam compared to a laser hybrid weld (SZW Union NiMoCr).



	MSG / UP	Hybrid
Re _H [N/mm ²]	950 - 971	1247 - 1255
Rm [N/mm ²]	983 - 998	1268 - 1262
A [%]	24/10 - 23/11	7/11 - 7/10

4

Double-sided rail systems and a crane are used to insert the stitched segments into the hybrid-welding machine. The laser-MSG hybrid welding machine is equipped with a 12 kW fiber laser. It is a large gantry plant with a work volume of 19.5 m x 3.5 m x 2.5 m. An industry partner developed this system especially for this application. The laser hybrid-welding head is automatically positioned using a weld seam-tracking sensor (Fig. 2).

A test series of 1000 sections was welded to demonstrate that all warpage and weld seam quality (Fig. 4) requirements were exceeded by the plant.

- 1 Tack welding of mobile crane segments
- 2 Hybrid welding process
- 3 Modern mobile crane with telescopic section boom

CONTACT

Dr. Axel Zwick
 phone: +49 231 844-3512
 axel.zwick@iws.fraunhofer.de



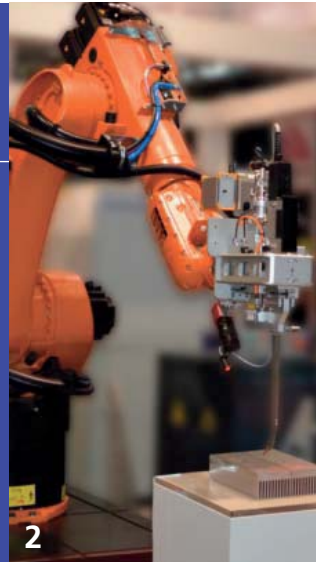
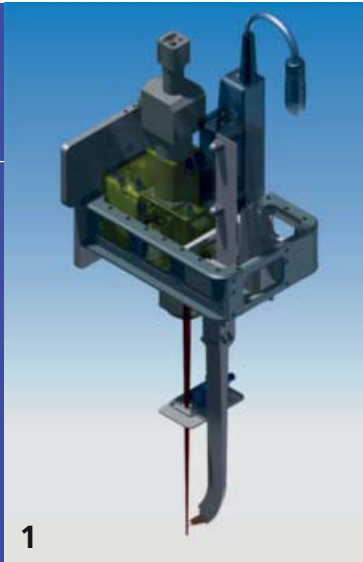

LASER MULTI-PASS NARROW GAP (MPNG) WELDING OF ALUMINUM ALLOYS OF UP TO 50 MM THICK SHEETS

THE TASK

Aluminum is economically the most important lightweight metal. The metal offers very high specific strength, very good corrosion resistance and excellent formability. Its properties make it suitable for an increasing application spectrum of highly loaded lightweight constructions. Aluminum is commercially available in the form of extruded profiles or cast semi-finished products. Ever more applications require aluminum welding.

The high thermal conductivity, heat capacity and large coefficient of thermal expansion of aluminum make it to a hard-to-weld material. With the availability of multi kilowatt lasers it became possible to extend the weldability of aluminum sheets up to 10 mm thickness. However, additional difficulties arise due to insufficient dilution of weld filler materials in the seam root, especially for deeper weld seams. This increases the risk of hot crack formation especially for heat treatable aluminum alloys (e.g. 6082).

The task for Fraunhofer IWS scientists was therefore to develop an industrial solution to laser beam weld thicker aluminum sheets (of up to 50 mm).

OUR SOLUTION

A new welding technology was developed. The so-called laser multi-pass narrow gap welding (MPNG) process works with affordable laser sources to produce deep welds with homogeneously distributed alloying elements.

Solid-state lasers are used with brilliant beam quality. The beam is very well focusable and thus reaches deep into narrow gaps with large aspect ratios. For typical gaps of 2 - 3 mm the beam reaches down to the bottom of the gap. A multi-pass welding process is applied with lower laser power to weld sheets of up to 50 mm thickness.

The homogenous dilution of alloying elements is achieved by oscillating the beam at high frequency perpendicular to the flanks.

The new solution overcomes three traditional limitations for thick sheet welding processes:

- absence of a technical solution,
- insufficient process safety due to hot crack formation and
- high investment.



RESULTS

The laser MPNG process was tested welding AlMgSi alloy sheets with thicknesses up to 50 mm. The resulting high quality welds were crack-free and nearly flaw-less. The process results were reproducible. The MPNG process ensures homogenous melting of the component flanks, guarantees high aspect ratios and thoroughly mixes the melt with the weld filler material AlSi12. The Si content is on average 7.5 % across the weld seam, which is prone to hot crack formation. The Si content is also sufficient at 3 % in the root of the weld seam.

Tensile strength comparison of MPNG welded test samples from heat treatable aluminum 6082

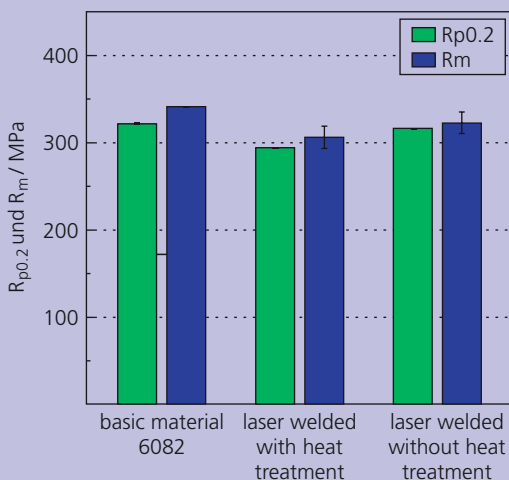

4

This process requires only 2 - 4 kW laser power to weld 50 mm sheets. Therefore the heat impact on the workpieces is low and distortion is substantially reduced.

Of particular advantage is that the distortion does not increase for thicker sheets. In the studied case it was actually shown that the distortion was reduced (Fig. 3). The porosity corresponds to class B (DIN 13919-2). The weld seam therefore meets the highest performance level. There are also no cracks in the weld material.

The very good weld seam quality leads to high static performance numbers (Fig. 4). For welded and polished samples these correspond to 90 % performance of the basic material. Heat-treating the welded material increases the strength of approximately 94 % of the basic material.

- 1 Laser MPNG laser welding head (CAD drawing)
- 2 Prototype of a MPNG laser welding head
- 3 Cross section of weld seams
 - a) conventionally welded
 - b) laser MPNG welded

CONTACT

Dr. Dirk Dittrich
 phone: +49 351 83391-3228
 dirk.dittrich@iws.fraunhofer.de



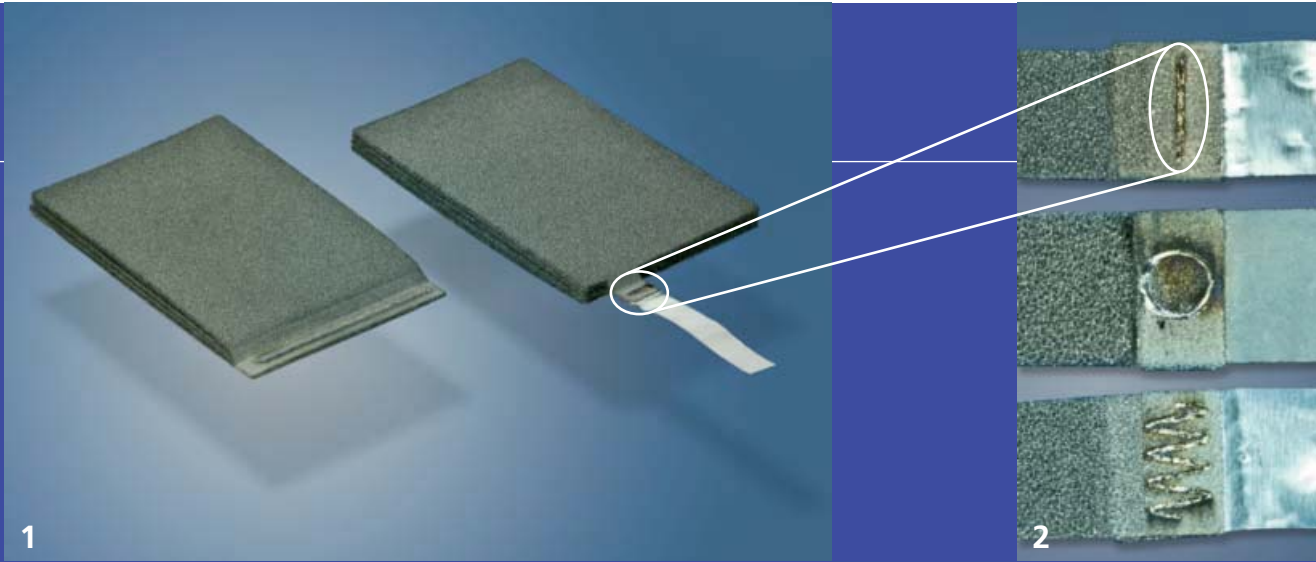

JOINING OF METAL FOAMS FOR ENERGY STORAGE DEVICES

THE TASK

The demand for energy storage devices continuously increases due to the rising electrification of private and public transportation and the transition of Germany's energy policy. The performance of electrical energy storage devices needs to be improved for mobile and stationary applications. Fraunhofer IWS engineers in Dresden work on novel electrochemical, material and manufacturing concepts for battery cells.

Using metal foams as electrodes offers a very high specific active surface area with respect to material volume and weight. However, such open and more than 90 % porous cellular materials pose a challenge in terms of connecting them to the battery tabs. In addition to mechanical strength requirements, such connectors need to have low contact resistance and they have to be chemically stable. The foam structures are loaded with active material. Therefore they need to be processed in an inert gas environment.

OUR SOLUTION

Chemical, materials science and process technology competences in battery research are bundled and expanded within the federally funded research projects "BamoSa" (BMBF, project number: 0344637A) and "BaSta" (BMW, project number: 0325563A).

The metal foams were studied for applications in three-dimensional current collectors. To connect the metal foams with the tabs, a joining technology is required which ensures a firm bond and which does not deposit too much heat into the electrodes. The joining process must also be performed in an inert gas environment. Therefore laser beam welding is the technology of choice since it features small spot diameters and low linear energy deposition densities.

The battery tabs are made from nickel, copper or aluminum. The metal foams are nickel, nickel-based alloys, copper or stainless steel. To connect them the first step is compressing the materials to stacks. The applied mechanical force strongly reduces the porosity of the foam material.

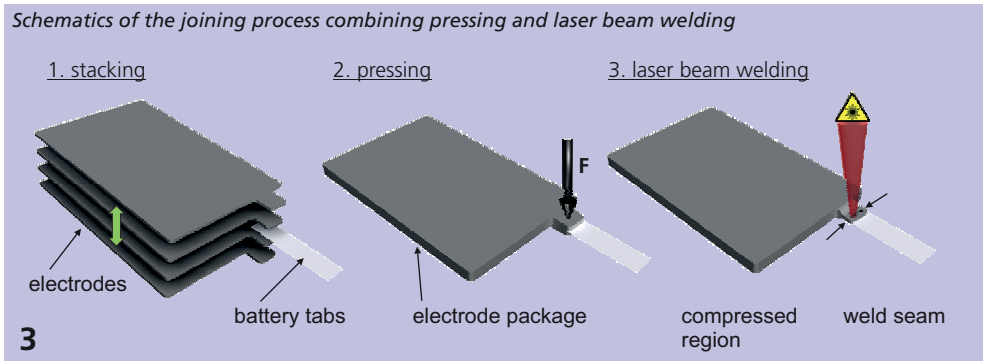



4

An additional form-fitting connection is introduced for thicker battery tabs (> 50 µm). These tabs have pre-punched holes to receive the foam when pressed. This technique provides both a form fitting and a frictional connection between metal foam and tab.

A laser beam welding process finally firmly bonds two materials in their compressed state. No filler material is required. The fiber laser beam is coupled via a protective window into the glove box, which holds the electrodes. Highly dynamic scanner technology is used to control the laser beam path to match the desired weld seam shape of the battery electrode (Fig. 2).

RESULTS

Experiments were performed with numerous connections and material combinations. As expected the cellular materials with smaller pore sizes are more stable during the welding process and also have a lower porosity in the resulting weld seam. This is caused by a stronger material accumulation during the compression of materials with smaller pore sizes.

The weldability of different materials depends on the metallurgical behavior of the melts and the coupling conditions of the laser radiation into the cellular material (Fig. 5).

The connections were mechanically tested and showed excellent tensile strength. Ultimately all samples failed in one or the other base material, not in the joint.

The electric conductivity of the connections was measured with a four-point probe setup. The contact resistance was always lower than the resistance of the metal foams.

By tailoring the battery tabs and combining compression and laser welding it is possible to firmly connect open cellular materials to foils. Typically the mechanical strength and electric conductivity of the joints exceeds those of the basic foam materials.

- 1 Battery electrodes with welded aluminum tab
- 2 Different seam geometries
- 4 Polished cross section of a welded joint with 4 layers of stainless steel (1.4404), metal foam and battery tab

Weldability of different material combinations

foam material	tab material		
	nickel	copper	aluminum
nickel	very good	good	limited
nickel-based	very good	good	limited
copper	limited	limited	very limited
stainless steel	good	medium	medium

5

CONTACT

M.Sc. Thomas Feustel
 phone: +49 351 83391-3665
 thomas.feustel@iws.fraunhofer.de



HEAD OF DEPARTMENT
PROF. DR. CHRISTOPH LEYENS



"Ideas are nothing unless acted upon."

Alfred North Whitehead



BUSINESS UNIT THERMAL COATING AND ADDITIVE MANUFACTURING

Editor: Prof. Leyens, thermal spraying with suspensions is an area where IWS is internationally leading. What are the success factors?

Prof. Leyens: Suspensions have a number of technological advantages over powders. Suspension spraying with very fine particles can produce novel coatings, which are superior to conventional coatings in many ways. Thin and thick coatings can be deposited just as porous and dense coatings. Certain materials which are important for the application and not sprayable by conventional means, can be made with phase compositions. In recent years we have developed a comprehensive understanding of the mechanisms linking the spraying process with the material structure and the coating properties. This know-how allows us to develop tailored coating solutions, which are highly appreciated.

Editor: How much have the recent developments of system technology contribute to the success of this technology?

Prof. Leyens: The stability of suspension spraying processes relies on the uniform delivery of the suspensions. We have developed a production-compatible suspension feeder to supply a continuous spraying process using its three reservoir vessels. These vessels can also be filled with different suspensions to develop new material combinations or graded coating systems. We also developed nozzle systems to inject the suspensions. This way it is possible to retrofit conventional spraying guns with suspension spraying capabilities.

Editor: IWS frequently offers innovative systems technology for buildup welding and additive manufacturing processes. What is the status?

Prof. Leyens: Our special strength is the development of custom-tailored solutions, which require substantial know-how of materials and manufacturing technologies. Technically mature and economically meaningful results are finally only achievable if the system technology is ready to meet process and product needs. Consequently IWS offers a family of robust powder nozzles, which cover a wide range of applications. Our customers are using these sophisticated systems for generating structure widths from 30 μm to 20 mm. The youngest member of this family is a wire based coaxial head for laser powers up to 4 kW. This head uses 100 % of the feedstock material and is completely 3D capable.

Editor: What is the progress in the field of functional materials, which are processed via aerosol and dispenser printing technologies?

Prof. Leyens: Special functional materials can be combined to form thermoelectric generators (TEG), which directly convert heat to electricity. The scientific challenge is to evaluate materials with high conversion efficiencies which are also inexpensive and environmentally compatible. Here we collaborate with partners from industry and science. On the processing side we recently demonstrated the fabrication of flexible TEGs, which are suitable power sources for sensors.



COMPETENCES

THERMAL SPRAYING

The group offers atmospheric plasma spraying (APS), flame and high velocity flame spraying (HVOF and HVAF) technologies using powders and suspensions to coat parts made from steel, lightweight metals and other materials with metals, hard metals and ceramics. Core competences include the development of appropriate coating solutions that match application requirements, the development and fabrication of system components and their integration into adapted machine concepts. The implementation of technologies at the user is an important aspect of know-how transfer activities.

BUILDUP WELDING

The competences of this group include the application of laser wire and powder buildup welding processes for coating tasks and surface functionalization. The engineers focus in particular on the customized development of coating heads, component technologies and CAM software. Industrial customers benefit from the long-term experience of our group in the areas of process development, systems technology and onsite support during technology transfer. We also provide comprehensive consulting, education and training services.

PRINTING TECHNOLOGIES

Printing is a high precision and very reproducible process to deposit 2D and 3D structures on surfaces at low costs. The precise and flexible application of multi material systems and the additive generative building of micro components make products with radically new functionality and property profiles possible. Such innovative fabrication technologies are used, for example, to integrate printed electronics such as sensors, thermoelectric generators or energy storage devices into components.

ADDITIVE MANUFACTURING

The group concentrates on the development of additive manufacturing processes for the efficient and flexible manufacturing of customized products. Modern metal and non-metal materials are processed into functional components and structures. The procedures are applied for repair and new part manufacturing, which have to meet complex wear requirements. The unique feature is a comprehensive multi-scale and material product engineering approach, so that customers from the most diversified sectors will benefit from our tailored solutions.



GROUP LEADER
THERMAL SPRAYING

DR. FILOFTEIA-LAURA TOMA

phone +49 351 83391-3191
filofteia-laura.toma@iws.fraunhofer.de



HEAD OF DEPARTMENT

PROF. CHRISTOPH LEYENS

phone +49 351 83391-3242
christoph.leyens@iws.fraunhofer.de



GROUP LEADER
LASER CLADDING

PROF. STEFFEN NOWOTNY

phone +49 351 83391-3241
steffen.nowotny@iws.fraunhofer.de

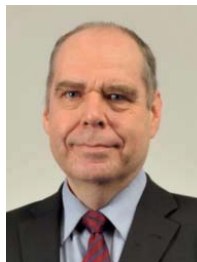

2014 PROJECT EXAMPLES

GROUP LEADER
PRINTING TECHNOLOGIES

DR. INES DANI

phone +49 351 83391-3405
ines.dani@iws.fraunhofer.de



- | | |
|---|----|
| 1. Laser based manufacturing of metal fiber composite joints | 46 |
| 2. Laser wire buildup welding with coaxial processing optics | 48 |
| 3. Suspension spraying – Components for industrial deployment | 50 |
| 4. Electricity from the roll – materials for flexible thermoelectric generators | 52 |
| 5. Additive manufacturing of thermally highly stressed components | 54 |

GROUP LEADER
ADDITIVE MANUFACTURING

DR. FRANK BRÜCKNER

phone +49 351 83391-3452
frank.brueckner@iws.fraunhofer.de



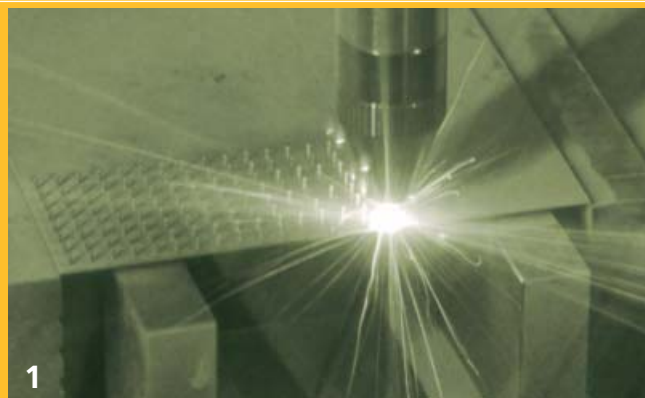

LASER BASED MANUFACTURING OF METAL FIBER COMPOSITE JOINTS

THE TASK

Automotive and aerospace companies increasingly integrate lightweight materials into their products to sustain energy efficient mobility. One example is the use of lightweight fiber reinforced composite materials in bodywork, enclosures and drivetrain components. However, integrating such materials into the overall concept is difficult due to the substantial deviation of their properties from the other materials, which are mostly metals. So far these materials have been incorporated through adhesive bonding, by laminating them with metals and by using additional mechanical connections such as rivets. However, such connections are often only local and of relatively low strength.

Rivets and screws often damage the fibers, which weakens the entire composite in areas of high mechanical loading. The precise positioning of connectors during the manufacturing process requires substantial effort. In addition the functional elements such as hinges or clamps have to be separately fabricated.

Eliminating these drawbacks implies the opportunity to reduce the manufacturing times of such components. Lightweight materials would become more efficiently usable in the industry. In some cases overcoming these deficits would enable certain lightweight design solutions to be manufactured. Therefore current research focuses on improving the fabrication efficiency and on the use of lightweight components made from fiber reinforced composite materials.

OUR SOLUTION

Fraunhofer IWS engineers apply high precision laser powder buildup welding to create special surface structures on metallic parts (Fig. 1). A large number of the structures (shown in Fig. 3) contribute to displacing exposed fibers during the joining process without destroying them. These fibers are then safely anchored during the subsequent lamination process.

High precision laser powder buildup welding is used to generate cylindrical structures and can also create geometric undercuts. These undercuts are critical to positively interlock the fiber composite (Fig. 2).

The process-intrinsic geometric flexibility permits the three-dimensional arrangement of individual structure elements on spatially curved connecting surfaces. The structure elements can be scaled from micro- to millimeters so that

they can meet various requirements such as material thickness, fiber content and fiber orientation.

A novel approach to connect fiber-reinforced polymers with metals is based on a laser process that combines metal infiltration with structure generation. During this process the generation of metallic functional elements

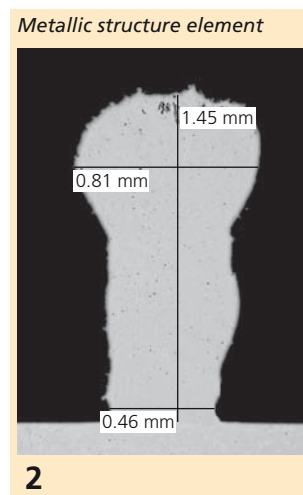

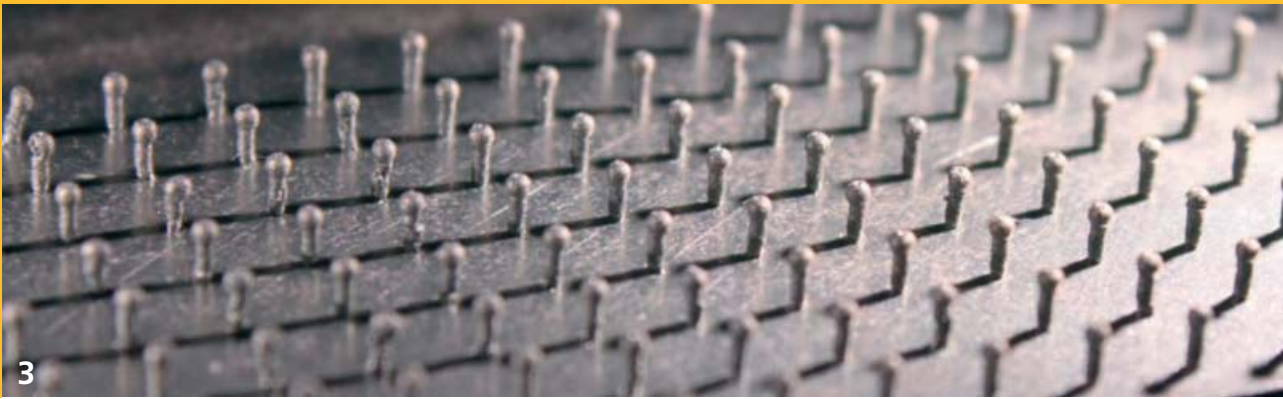

on the fiber composite material directly creates a high-strength material and interlocking bond with the structural component (Fig. 4a).

The laser melts the metal, which penetrates into the exposed volume between the fibers while forming a weld seam. The subsequent buildup process gradually transitions from the metal required for the joint to the metal building the functional elements. The properties of the metallic functional element can be tailored to the application.

Mechanism of forming a strong material interlocking connection across several fiber layers (a) and polished cross section of the metal – CFC connection (b)

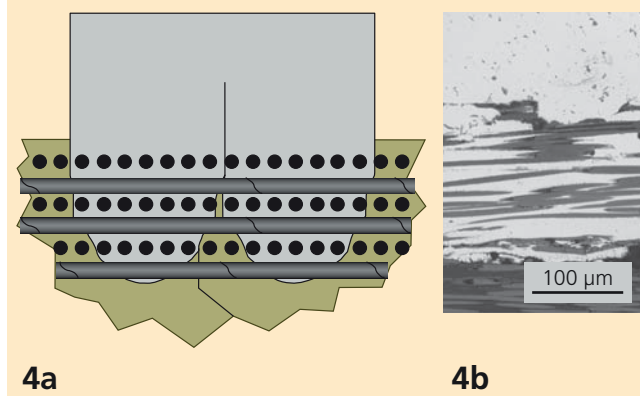

to metal. The test results demonstrated the outstanding potential of such structures and by far surpassed the strength of adhesively bonded connections.

Direct metal infiltration was achieved by depositing metal weld seams onto carbon fiber reinforced composite materials. The polished cross section of the weld seam (Fig. 4b) illustrates the high-strength connection between the fiber reinforced polymers and metal, which was achieved by displacing the matrix. Thermal damage to the composite material remains minimal.

- 1 High precision laser powder buildup welding during the generation of filigree surface structures
- 3 Surface structures applied over a large surface area

RESULTS

High precision laser powder buildup welding can be used to generate structural elements on substrates, which are tailored to specific loading conditions. The cross section of the structure is adjusted to either enable an easy fiber displacement or to create the best possible interlocking. Tensile strength testing was performed with polyamide joined

CONTACT

Dipl.-Ing. Mirko Riede
 phone: +49 351 83391-3188
 mirko.riede@iws.fraunhofer.de





LASER WIRE BUILDUP WELDING WITH COAXIAL PROCESSING OPTICS

THE TASK

Laser based surface coating and functionalization processes are demanding production applications of modern laser technology. The filler material is provided as metal powders or wires. There is a recent trend to more frequently use wires. Wire is 100 % utilized in the process on any given workpiece. Gravity is not an issue that would limit the wire delivery and the welding process is clean and much less hazardous for the operator and the machine.

It is also much less likely that the wire will be subject to undesirable chemical reactions with the surrounding atmosphere since its specific surface area is much smaller than that of powders. This is very advantageous for processing materials such as titanium and aluminum, which would be affected by such reactions. Filler wires further expand the spectrum of available alloys and hard materials.

Today the wire is often laterally delivered. This method limits the coating capabilities for contours and 3D objects. It also restricts the overall process window. The goal is to deposit coatings with very high surface quality that follow exactly the contours of the substrate surface in three-dimensional space. Moving the processing optics along such complicated paths would tremendously benefit from a wire delivery mechanism that can be equally freely moved in space without directional limitations.

OUR SOLUTION

The Fraunhofer IWS offers a practical solution to this issue in the form of the new laser wire coaxial processing optics **COAXwire** (Fig. 1). This optics is suitable for all applications, which demand precise two- and three-dimensional material deposition.

The system uses fiber or disk lasers of up to 4 kW power. The initial beam is collimated and split into three partial beams. These three partial beams are then focused into a circular focal point (Fig. 4). The diameter can be adjusted by selecting the fiber diameter while the optics has a constant imaging ratio of 1:3. The optical elements are arranged so that the wire moves directly along the central laser beam axis. Finally the wire tip advances into the laser-generated melting pool. This way the wire can be delivered in any direction that makes technical sense for a welding process.

The wire optics is equipped with collision protection and emergency shutoff features in case of errors or process issues. The compact design allows for easy CNC or robot integration. It is also highly suitable for processing large and complex workpieces.



2

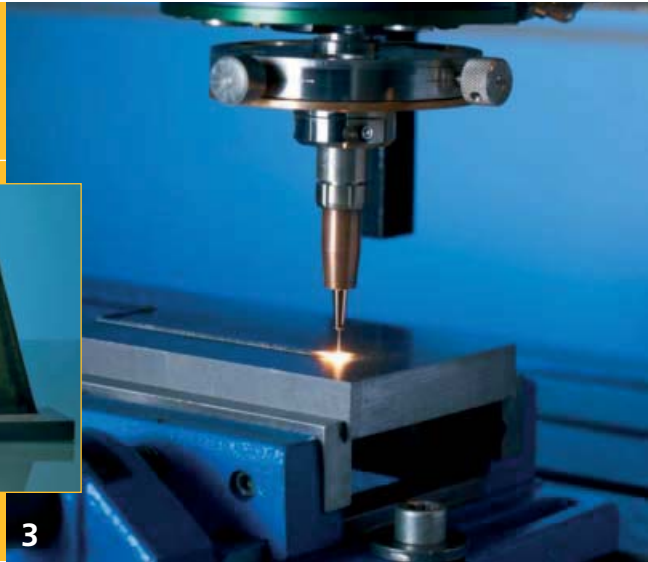

3

RESULTS

Fig. 3 illustrates the typical welding process. In arc-based processes the solid feedstock material transitions into the melt by forming droplets. This is not the case here. During the laser welding process the metal continuously melts off the wire tip and adds to the melt pool. The final geometry of the deposited metal depends on the metal's properties as well as the laser focus diameter.

Typical tracks have a width of 1 - 3 mm and a thickness of 0.3 - 1 mm. Wire diameters are between 0.8 and 1.2 mm. It is principally also possible to use finer wires down to 300 µm or thicker wires of up to 1.6 mm. Process control hardware includes a wire feed sensor, integrated safety shutoff electronics and optionally, a camera-based melt pool monitoring systems.

Schematics of a coaxial processing optics

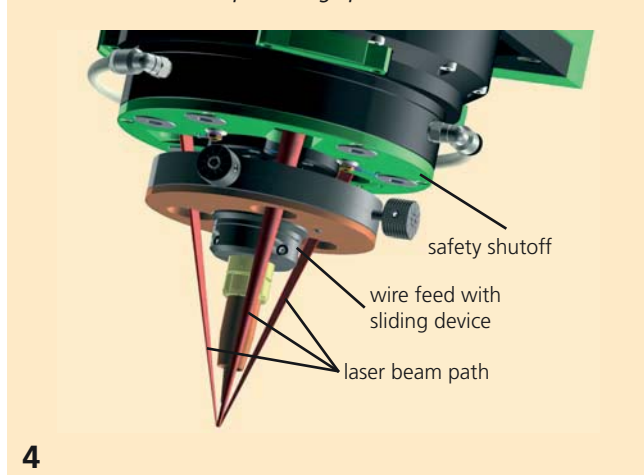

4

Applications benefit from a large spectrum of commercially available metal alloys to fabricate coatings and defect-free complex 3D structures (Fig. 2). Representative examples include the tool steel 1.2343, the nickel alloys Inconel 718 and 625 and the cobalt-based alloys Stellite 21. Also available are the lightweight construction alloys TiAl6V4 and AlMg5. The deposition rates depend on workpiece geometry, material and wire dimensions. The typical areal coverage rates are up to 0.5 m²/h and the volume buildup rate can be as high as 250 cm³/h.

Laser buildup welding processes with wires show the tendency to generate better surface qualities than powder based processes. For example, a wire deposition of Inconel 625 has a surface roughness of $R_z < 45 \mu\text{m}$ when measured perpendicularly to the welding direction. The smoother deposition results in lower oversize and reduced costs for finishing the part.

- 1 Coaxial laser wire processing optics COAXwire
- 2 Workpieces created by generative deposition
- 3 Buildup welding process with coaxial wire optics

CONTACT

Dipl.-Ing. Sebastian Thieme
 phone: +49 351 83391-3076
 sebastian.thieme@iws.fraunhofer.de





1



2

SUSPENSION SPRAYING – COMPONENTS FOR INDUSTRIAL DEPLOYMENT

THE TASK

Suspension spraying techniques enable thermal spray coatings of very high quality. The spraying powders are of sub-micron or even nanometer size and finely suspended in a liquid. Conventional thermal spray processes use powder sizes from 5 to 50 μm . Compared to conventional coatings, suspension sprayed coatings have a much smoother surface and a more homogeneous microstructure.

Suspensions can be sprayed using conventional thermal spray technologies such as high velocity oxygen flame (HVOF) spraying and atmospheric plasma spraying (APS). However, special suspension feeders and injectors are required so that the suspension can be delivered to the plasma or to the HVOF flame.

So far such hardware components have only been available on a laboratory scale. The task is to develop a cost effective set of components that can be used in existing thermal spray systems. This should be attractive to companies that are interested in the benefits of suspension sprayed coatings.

OUR SOLUTION

Fraunhofer IWS engineers developed a modular set of components for industrial use. The set consists of an automatically operated suspension feeder, a connector box and various suspension injectors for APS and HVOF processes (Fig. 3).

The suspension feeder has three separate pressure vessels (Fig. 1). Two vessels contain the desired suspensions and the third provides a cleaning fluid. The system offers advantages

in particular for continuous deposition processes. While the suspension is delivered from one vessel, the second can be refilled. Alternatively it is possible to use two different suspensions to deposit multilayers or composite coatings.

The suspension feeder is operated via touch screen panel. Parameters such as flow rates and pressures can be adjusted and monitored. The amounts of suspensions are automatically and individually adjustable. At the end of the deposition or during process breaks it is possible to perform a cleaning cycle to avoid particle sedimentation throughout the delivery system.

The connector box controls the valves between suspension feeder and injector. Fraunhofer IWS injectors are suitable for APS system technology (F6 and Delta) and for TopGun HVOF systems (Fig. 2). Spraying guns readied for suspension spraying can be easily reconfigured for powder spraying by swapping the injectors.

System components for suspension spraying: Suspension feeder, connector box and injector.

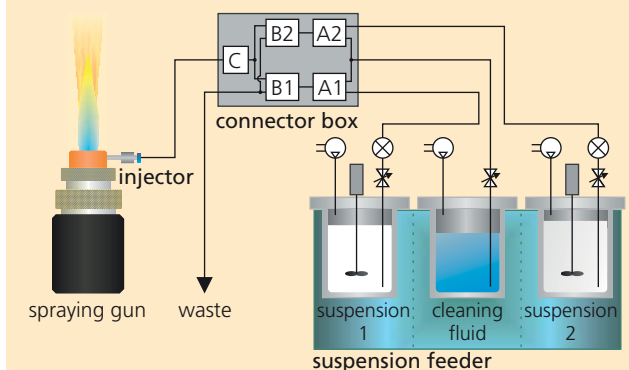

3

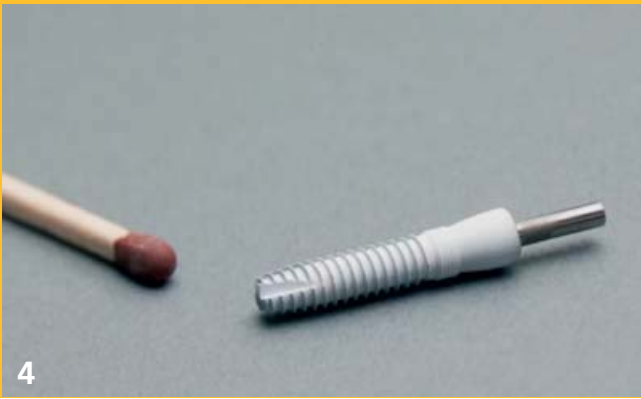

RESULTS

The modular set of suspension spray components enables the deposition of coatings that cannot be generated by other thermal spraying processes. An example is the coating of dental implants with thin, smooth, stable, biocompatible and white suspension sprayed films (Fig. 4). Under industrial production conditions the continual suspension spraying process would increase throughput since it does not have to be interrupted.

The suspension feeder enables the direct deposition of composite coatings (ceramic-ceramics, ceramic-metal) and multilayer coatings (Fig. 5). During the deposition of composite coatings the different suspensions are simultaneously injected into to the spraying process. This guarantees a homogeneous distribution of the different microstructures in the resulting coatings. When spraying multilayer coatings, the different

suspensions are simply alternated, semi-automatically and without delay. The system does not have to be shut off to create multilayer coatings with sharp transitions between the alternating microstructures.

IWS offers comprehensive services for spraying with suspensions. These include the development of hardware components, the testing of suspensions for customers and the development and characterization of tailored suspensions and coating solutions. IWS engineers also support the user to introduce the technology and to integrate it into their systems.

- 1 Suspension feeder
- 2 Suspension injectors for HVOF (bottom) and APS (top) spraying
- 4 Coated dental implant with thin ($20\ \mu\text{m}$) ZrO_2 suspension coating

Polished cross-section of a composite coating (left) and a multilayer coating (right), the coatings were made from Al_2O_3 and TiO_2 water-based suspensions.

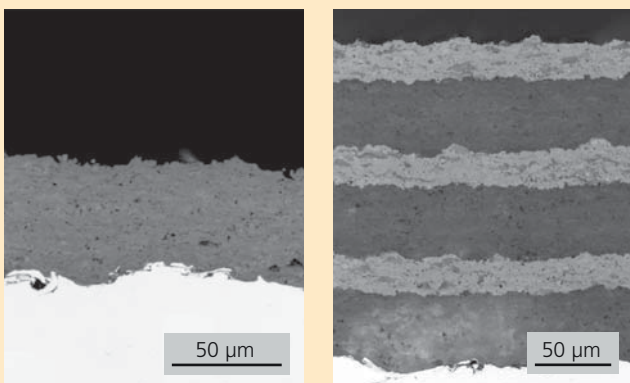

CONTACT

Dr. Filofteia-Laura Toma

phone: +49 351 83391-3191

filofteia-laura.toma@iws.fraunhofer.de





ELECTRICITY FROM THE ROLL – MATERIALS FOR FLEXIBLE THERMOELECTRIC GENERATORS

THE TASK

Thermoelectric generators directly transform thermal energy into electrical energy. Possible applications are numerous since nearly every technical process generates waste heat. Germany alone produces several petajoules of waste heat per year. Thermoelectric generators could be used to at least partially recover some of this dissipated energy.

The transformation from heat to electricity is based on the Seebeck effect. The effect describes the diffusion of charge carriers as a result of a temperature gradient across an electrically conductive material. The charge carrier diffusion in return builds up an electric potential difference, the so-called Seebeck voltage. This voltage is typically a few μV to mV. The Seebeck coefficient is a material constant for the thermo voltage obtained per Kelvin temperature difference.

A broad market acceptance of thermoelectric elements is currently inhibited by various difficulties. These include insufficient thermoelectric efficiencies of the available materials, their toxic properties, and high material and production costs to produce such generators for the industrial implementation.

Intrinsically electrically conductive polymers offer a promising alternative. Fraunhofer IWS scientists are therefore exploring p- and n-type conductive polymers. These are optimized with respect to their thermoelectric properties.

OUR SOLUTION

To expand the current application fields of thermoelectric solutions, IWS scientists develop flexible thermoelectric generators. The work focuses on the synthesis and optimization of p-type polymers such as poly(3,4-ethylenedioxythiophene):p-Toluene-Sulfonic acid (PEDOT:tos) and n-type polymers such as Poly[K_x(Ni-ett)]. Both polymers have a relatively high intrinsic electrical conductivity and offer the possibility to tailor the thermoelectric properties to different requirements. It is outstanding that both p- and n-type polymers remain chemically and electrically stable when exposed to humidity and oxygen.

Efforts to improve the thermoelectric performance of these materials aim at increasing the Seebeck coefficient and the electric conductivity, and at decreasing the thermal conductivity. These properties depend on polymer synthesis and post-processing steps. Such optimized materials are efficiently printed to build flexible thermoelectric generators.

RESULTS

To optimize the thermoelectric properties of the p-type polymer (PEDOT:tos) a solution consisting of monomer, solvent and initiator is spin-coated onto a glass substrate and polymerized using a heating plate. After washing, the obtained films are thermally treated and analyzed.



2

Thermal annealing improves the electric conductivity by 600 % to 30000 S m^{-1} (at room temperature). In its initial oxidized condition the Seebeck coefficient is typically about $15 \mu\text{V/K}$. Starting from a point of high electrical conductivity, chemical reduction processes are used to vary the Seebeck coefficient and to optimize the power factor. The oxidation state of PEDOT:tos is monitored via infrared spectroscopy (Fig. 3).

optical absorption spectra of PEDOT as a function of oxidation

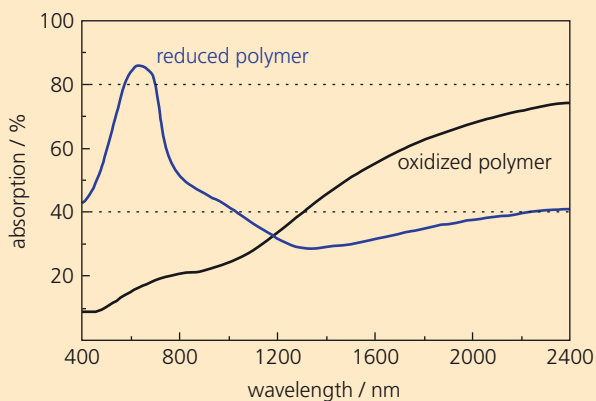

3

Synthesizing the n-type polymer (Poly[$K_x(\text{Ni-ett})$]) involves the chemical incorporation of a transition metal (nickel) into the polymer backbone. After successful synthesis, the polymer is an insoluble powder. However, a suitable dispersion process was developed using optimized binders and solvents to produce coatable dispersions. After deposition, the polymer is heat-treated at about $180 \text{ }^\circ\text{C}$ under ambient conditions, i.e., in the presence of humidity and oxygen.

Optimizing the thermal treatment processes improved the Seebeck coefficient as measured at room temperature from $-25 \mu\text{V/K}$ to more than $-70 \mu\text{V/K}$. Simultaneously the electrical conductivity of the n-type polymer increased by about 60 % to 2200 S m^{-1} (Fig. 4).

Such produced polymers are used to build flexible thermoelectric generators by depositing the suspension onto flexible fleece (patent pending).

specific conductivity of poly[$K_x(\text{Ni-ett})$] as a function of temperature during heating and cooling

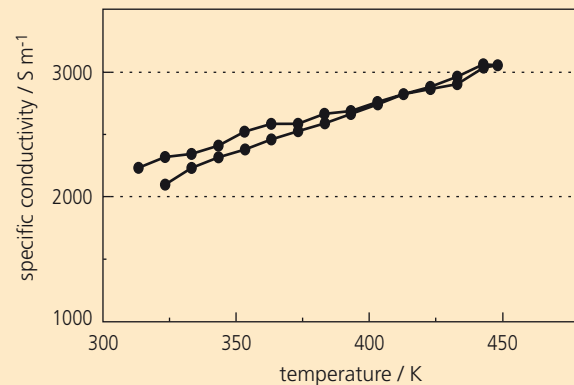

4

- 1 Equipment to synthesize Poly[$K_x(\text{Ni-ett})$]
- 2 Synthesized Poly[$K_x(\text{Ni-ett})$] polymer

CONTACT

M.Sc. Lukas Stepien
 phone: +49 351 83391-3092
 lukas.stepien@iws.fraunhofer.de





ADDITIVE MANUFACTURING OF THERMALLY HIGHLY STRESSED COMPONENTS

THE TASK

Gas turbines and jet engines are high-temperature applications for high performance materials. Operating temperatures exceed 700 °C. The materials need to be oxidation and corrosion resistant and thermally stable. Their creep and annealing properties need to be optimized. Casting and forging such high-temperature stable alloys is costly and requires enormous efforts. Even though these materials withstand high temperatures, components can still be damaged due to droplet impact or erosion. However, such impact erosion occurs only in certain regions of the part. Depositing replacement material can repair partially eroded and damaged volumes. This approach is less cost effective compared to the manufacturing a new component.

The manufacturing or repair of these parts through welding processes is challenging since nickel super alloys and novel titanium aluminides (γ -TiAl) are hard to weld.

The mentioned materials are also very hard to machine. Therefore rebuilding the structures requires to very precisely create the net shape of the original part.

OUR SOLUTION

With a tailored temperature regime, laser powder buildup welding is a suitable generative process to produce high performance materials. Precise process control and simultaneous induction heating of the workpiece suppress hot and cold crack formation. This hybrid technology is capable of processing hard-to-weld alloys with high quality.

The process is monitored using a Fraunhofer IWS temperature control system. A highly sensitive camera thermographically observes the metal surface during the process. The measured temperature dataset is compared to the desired temperature profile. If the deviations exceed the specification, the controller regulates induction and laser powers accordingly. The control system regulates the temperature over time so that the deposited material is defect-free.

In spite of the additional heat the precise process control realizes material depositions that require only minimal post processing.



2



3



4

RESULTS

Fig. 1 shows laser powder buildup welding equipment with integrated inductive heating. The machine can generate volume buildups from high temperature materials. Fig. 2 shows an example made from a γ -TiAl alloy. The sample is 65 mm tall and has a cross section of $1 \times 1 \text{ cm}^2$. The volume is free of cracks. The inner structure was evaluated using CT scans (Fig. 3) showing very low porosity.

After the laser powder buildup process (Fig. 5) there follows a heat treatment to optimize the mechanical properties of the brittle weld deposit. The microstructure of the heat-treated sample in Fig. 5 reveals γ -lamellas, which precipitated from super-saturated α_2 grains.

Microstructure of the as-generated TiAl volume (left) and after heat treatment (right)

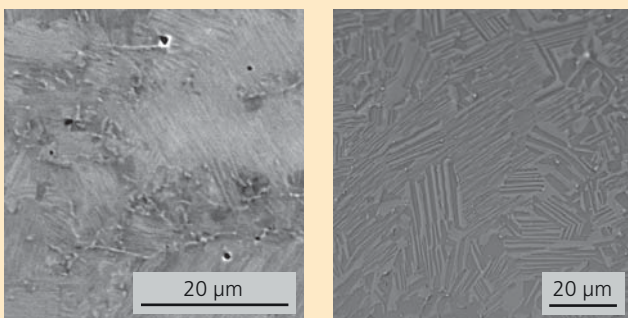

5

Another high performance material that can be processed in the described way is the nickel super alloy Mar-M247. Parts of various geometries were generated from this alloy using processes with controlled inductive heating. So far turbine blade repair relied on weldable materials, which have insufficient temperature stability. An example is the nickel base-alloy Inconel 625. In the future it will be possible to perform such repairs using hard-to-weld high temperature materials. Fig. 4 shows an example of a turbine blade, which was repaired at the tip.

- 1 Coaxial laser powder nozzle for generative deposition with added inductive heating
- 2 Laser powder welded volume buildup from TiAl
- 3 CT scan of the generated TiAl volume
- 4 Repaired tip of a turbine blade

CONTACT

Dr. Frank Brückner
 phone: +49 351 83391-3452
 frank.brueckner@iws.fraunhofer.de



**HEAD OF DEPARTMENT
PROF. DR. BERNDT BRENNER**



"The only proof of ability is in doing."

Marie von Ebner-Eschenbach



BUSINESS UNIT SURFACE TECHNOLOGY

Editor: Do you see changing customer requirements in the field of surface technologies?

Prof. Brenner: Just like in all other technology fields, our customers are driven to make their production processes more efficient, to save resources and to produce more cost-efficiently. They aim at cutting down process chains and at implementing 100% quality control of their products. That is why we have, for years, followed the approach of "integrated hardening". It is inefficient to interrupt mechanical processing lines to perform external heat treatments. Instead, we offer the integration of surface hardening directly inline. Last year we made substantial progress and collaborated with an internationally renowned manufacturer of high quality milling centers and developed modules that monitor buildup welding and laser hardening. The modules were integrated into several milling centers. This concept enables, for the first time, the direct inline combination of the milling step with laser buildup welding or laser hardening. The process is temperature-controlled and quality-assured.

Editor: What size of workpieces can be handled?

Prof. Brenner: The machine concept mentioned is designed for small to medium sized manufacturing volume parts. For larger or very large workpieces we have another concept. Laser beam shaping and temperature controlling units are combined in one model which is mounted to the arm of a robot and positioned on a caterpillar vehicle. The operator controlled robot drives to the position of the workpiece to be hardened. Here the robot is locked in position and the temperature-controlled hardening and robot motion programs are performed to harden the functional surface.

Editor: What's new in the field of technology development?

Prof. Brenner: Years ago we transferred a laser hardening process for turbine blades to industrial application. Now we are able to demonstrate the advantages of the process on three other precipitation-hardenable steels. Laser surface hardening is now available for six different precipitation-hardenable steels with different alloying concepts.

Editor: Surface hardening is one of the processes that result in materials with property gradients. In such cases the question becomes critical how cracks may develop and propagate under fatigue loads. How do you address such uncertainties?

Prof. Brenner: Crack propagation during fatigue stress is especially critical if the material is stressed below the classic fatigue strength and the crack develops underneath the surface. Early crack detection is necessary for two reasons. On the one hand process development requires information about crack initiation. The second question is about the critical size of defects, which leads to component failure during high frequency loading. We combined three analytical methods to develop an appropriate testing protocol detecting in-situ failures during high frequency fatigue testing. The protocol was verified with laser beam welded aluminum samples (pages 66/67).



COMPETENCES

TAILORED STEEL HARDENING BY LASERS AND INDUCTION

Conventional hardening technologies often fail in cases of specific component geometries, wear situations and materials. For these cases laser beam hardening and laser beam fusion offer novel solutions for the generation of wear resistant surfaces. This is particularly true for the selective hardening of components with multidimensionally curved, internal or hard-to-reach surfaces, bores or grooves as well as components sensitive to warpage. The workgroup offers:

- development of surface hardening technologies with lasers or induction or both
- surface refinement of development and prototype samples
- development of systems technology for process monitoring and control

COMPLEX MATERIALS AND COMPONENT CHARACTERIZATION

Mastering modern joining and surface technologies requires wide knowledge, from interpreting structural changes to understanding how they affect component properties. The group offers access to modern equipment for structural analysis (metallography, SEM with EDX / WDX, HRTEM) and mechanical testing (among others, high frequency and multi-axial fatigue testing). Our customers can rely on many years of experience in the field of structural and component reliability testing. The group is a competent partner to perform property evaluation, failure analysis and application focused training.



HEAD OF DEPARTMENT

PROF. BERNDT BRENNER

phone +49 351 83391-3207

berndt.brenner@iws.fraunhofer.de



**GROUP LEADER
SURFACE TREATMENT**

DR. STEFFEN BONSS

phone +49 351 83391-3201

steffen.bonss@iws.fraunhofer.de



2014 PROJECT EXAMPLES

1. Enhanced properties of modern steels by laser surface age hardening 60
2. Networked system technology for laser processing 62
3. Deformation behavior of steels depending on strain rate 64
4. In-situ-characterization of the damage evolution during high frequency fatigue testing 66

**GROUP LEADER
MATERIALS CHARACTERIZATION**

PROF. MARTINA ZIMMERMANN

phone +49 351 83391-3573

martina.zimmermann@iws.fraunhofer.de



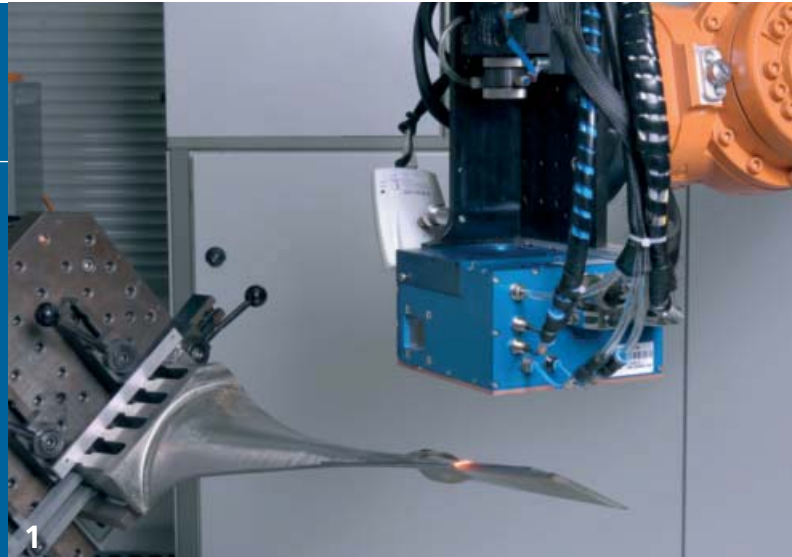

ENHANCED PROPERTIES OF MODERN STEELS BY LASER SURFACE AGE HARDENING

THE TASK

Precipitation-hardening is the most important mechanism utilized to strengthen materials such as Al-, Ti-, Ni-, Cu-alloys and specific steels. For many applications precipitation-hardening of materials must guarantee high ductility and toughness. For this reason these materials are normally used in an overaged but not in the peak aged condition. However, in an overaged condition the materials do not exhibit the maximum strength, hardness and wear resistance which would be desirable for some applications.

This limitation applies in particular for precipitation-hardening martensitic stainless steels which offer a good combination of strength, ductility and toughness, good fabrication characteristics, corrosion resistance and a superior fatigue performance. Therefore these steels are commonly used for structural components in aircraft, chemical, naval, nuclear and power generation industries. However, if the application requires a higher wear resistance commonly used thermal hardening treatments are not applicable.

To overcome this drawback an effective surface modification technique has been developed at Fraunhofer IWS Dresden, which allows the selective generation of wear resistant surface regions up to several millimeters in depth without altering the mechanical properties in the bulk of the material.

OUR SOLUTION

Our new approach assumes that the different demands on surface and bulk properties can be achieved by specifically

adapted heat treatment cycles. In the first step the whole component is solution-annealed and subsequently precipitation-hardened at relatively high temperatures (overaging) to obtain the required bulk properties optimized for the demands of strength, fatigue and toughness. The second step consists of selective short-time laser surface solution-annealing (austenitization) at unusual high temperatures to completely dissolve the precipitations in the near surface region and to maintain the solid solution condition upon rapid self-quenching and phase transformation to lath martensite. Finally, the whole component is aged at relatively low temperatures to optimally strengthen the solution-annealed surface regions.

In order to accomplish the laser solution-annealing, the process development and equipment of conventional laser beam hardening can be utilized. These include, for example, modern high power diode lasers, beam shaping optics, robots and temperature measuring and control systems.

To evaluate the capability of this novel laser based surface age hardening technique and to enable its application to several modern high performance steels, a profound knowledge of the physical and structural processes involved was achieved with a systematic investigation of hardness, microstructure and wear resistance of samples in the as-delivered and surface age hardened state.

RESULTS

The novel surface age hardening technique was adjusted and successfully applied in order to maximize the wear resistance of low pressure turbine blades made of the steel

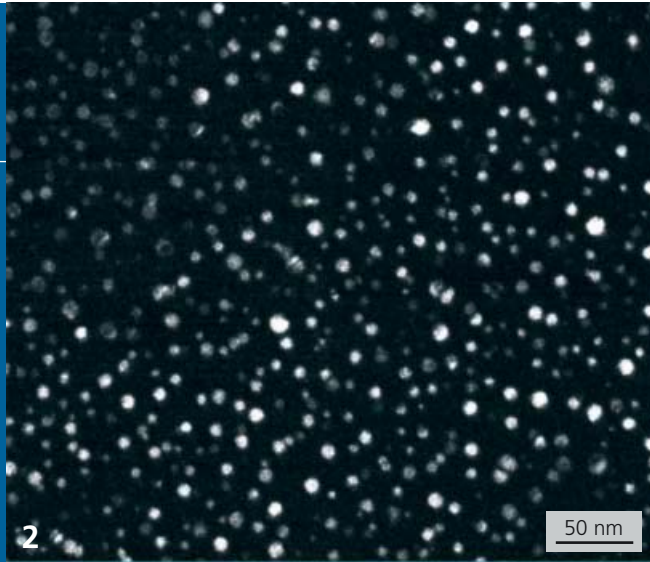

17-4 PH (X5CrNiCuNb16-4) against water droplet erosion for a series of applications of steam turbines at Siemens Power Generations (Fig. 1).

Based on this success the process was adapted and successfully transferred to two further precipitation-hardening steels: 15-5 PH (X5CrNiCuNb15-5) and PH 13-8 (X3CrNiMoAl13-8-2). By choosing the appropriate laser and aging treatment, the hardness of these steels can be increased by more than 150 HV up to a depth of 4 mm. The increase in hardness is accompanied by an improvement of the resistance against cavitation erosion. Compared to the as-delivered condition the resistance against cavitation erosion can be increased by a factor more than twice the original value. Moreover, the tensile strength of the hardened surface can be increased by more than 50 % compared to the bulk material.

Scanning and transmission electron microscopic analyses (SEM and TEM) verified that the improved properties of the age hardened surface are accomplished by a more homogenous and finer precipitation arrangement. The properties-determining Cu and Ni₃Al precipitations in the age hardened surface are generally smaller than 10 nm and thus much smaller than in the bulk (Fig. 2). Further positive effects of the laser surface annealing are the dissolution of coarse carbides and a substantially higher thermal stability of the precipitations.

The novel laser based surface age hardening allows to overcome drawbacks which are associated with the application of conventional surface hardening techniques on precipitation-hardening steels. By introducing gradients into the size and the amount of precipitations and hence producing gradual variation of mechanical properties, a selective tailoring of the materials properties can be realized. Therefore, the material is enabled to withstand severe wear loading conditions during application while preserving its

outstanding overall mechanical and environmental behavior (e.g. toughness, ductility, corrosion) provided by the accordant type of precipitation-hardening alloy. It is assessed that the technique of laser based surface age hardening can be applied to a wide range of modern precipitation-hardening alloys. Hence, an exceptional potential to provide essential improvements of mechanical performance in highly-demanding applications is waiting to be exploited.

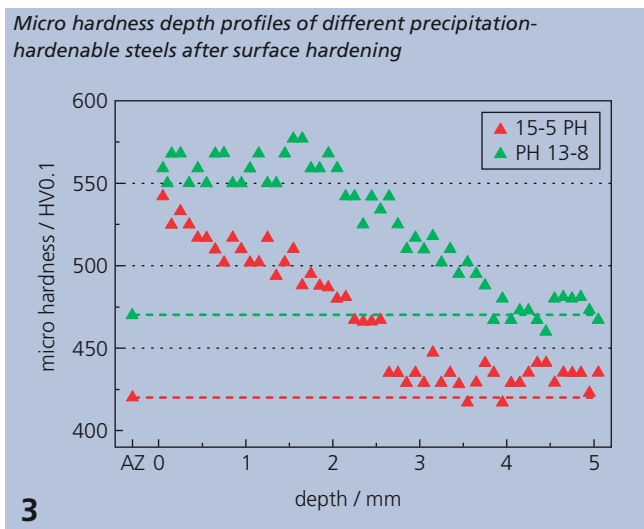

- 1 Laser surface annealing of the leading edge of a turbine blade
- 2 TEM dark field image of Ni₃Al precipitations in surface region of hardened steel X3CrNiMoAl13-8-2

CONTACT

Dr. Jörg Kaspar
 phone: +49 351 83391-3216
 joerg.kaspar@iws.fraunhofer.de



NETWORKED SYSTEM TECHNOLOGY FOR LASER PROCESSING

THE TASK

Laser processing machines are highly complex systems. Principally they consist of a motion system, a laser beam source and a process control system. However, to ensure safe processing and to set up the system for specific applications, numerous other components are added. These include, for example, measurement probes, tool changers, process gas controllers and safety relevant devices. Additional process specific devices are the temperature measurement system "E-FAqS"/ "E-MAqS", the laser beam shaper "LASSY", the laser beam monitor "LasMon" and the laser fiber breakage or bending sensor "MOPS".

Each individual system component features several input and output interfaces. The increasing complexity of combined systems results in numerous predictable and unpredictable errors of various types including component failures and operator errors. Ideally such errors just create simple error messages instead of causing component damage. An especially critical phase of deploying these systems is the initial startup followed by first application tests. During this phase operator errors are frequent. Other typical error sources include varying environmental and climatic conditions as well as specific customer setups and different technical backgrounds of the users. On the other hand, customers expect a simple user interface, high reliability and unlimited availability of the system at optimized costs.

OUR SOLUTION

It is a paradox – to meet these requirements one has to further increase the complexity of the systems. System stability is usually improved by implementing redundant sensors for each measurement. In many cases this redundancy already exists due to the presence of sensors, which are included in many individual system components.

Using such diverse redundancy is state-of-the-art in the area of functional safety technologies to protect people. However, identical principles are also suitable for error handling in non-safety oriented systems.

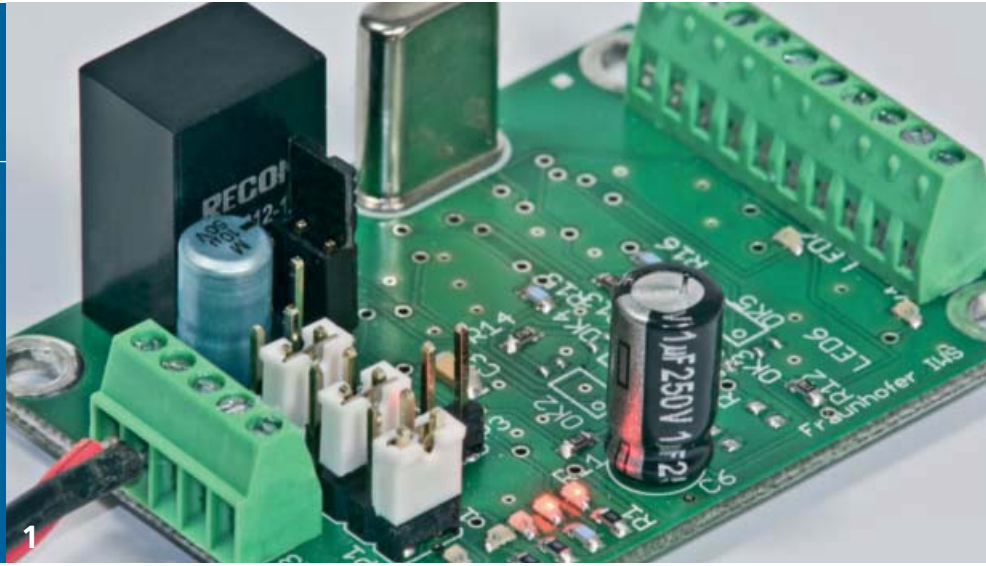

RESULTS

In addition to process relevant sensors, Fraunhofer IWS engineers use components that have no direct function for the laser process but serve exclusively to diagnose the system. Examples are the sensors included in specifically developed system components, which measure the transient behavior of the power supply, temperature and acceleration. Such sensors are inexpensive, compact and easy to integrate. Using many sensors will help to detect all possible error states.

Due to the high number of sensors and the need to process the data, Fraunhofer engineers exclusively rely on field bus sensors. Employing field buses makes systems expandable, simply by connecting other components. In-house developed components in the form of customized circuit boards are also field bus compatible.

The data volume is substantial and cannot be analyzed by the operator. The analysis is performed using IWS developed software, which diagnoses errors in individual components and also creates a customized functional model of the overall system to permanently compare all data. This software model is visualized on the field bus level. It reports the state of individual sensors but also complex error chains. This approach supports effective and fast error correction (Fig. 1).

All detected events and states are recorded. These recorded data are used to further improve the system model and to create future automated maintenance instructions. The model and all active states can also be provided online to the equipment manufacturer. This remote access is essential to provide comprehensive support during startup and training as well as during failure analysis and maintenance.

Remote access to system sensors is augmented by sound and video transmissions. Operators can be instructed via headset and live feeds of the process can be simultaneously transmitted to the support team. It is possible to remotely prepare the entire system for a specific task or a new laser process. Principally the entire process can be remotely controlled.

Consequently networking all system components is in many aspects compatible with the "Industry 4.0" concept addressing future manufacturing. Most important however is the substantially shortened response time during startup and in case of system failures. The possibility to provide comprehensive support without being on site is more effective and reduces effort and costs.

1 Controller board of the camera system "E-MAqS" with integrated ASI bus

CONTACT

Dipl.-Ing. Jan Hannweber
 phone: +49 351 83391-3360
jan.hannweber@iws.fraunhofer.de





DEFORMATION BEHAVIOR OF STEELS DEPENDING ON STRAIN RATE

THE TASK

Currently there is a strong demand for simulations predicting the forming or crash behavior of components and during the manufacturing of semi-finished product (e.g. metal sheet and massive part forming behavior). Typical for such processes is the creation of large plastic material deformations in short time intervals.

Simulation software implements specific material models, which provide elastic and plastic deformation data as a function of elongation, temperature and strain rate. In many cases these data are provided in the form of flow curves such as $\sigma = (\epsilon, T, \dot{\epsilon})$. The reliability of simulation results depends on the quality of the implemented material models and the required parameters.

The behavior of steel tubes (X39CrMo17-1) during massive forming with inside pressure is subject of a joint simulation project involving the Fraunhofer institutes IWU Chemnitz, IWS Dresden and ICT Pfinztal. The material behavior is provided by the software package "simufact", which is based on the material model of Hensel and Spittel. The task for IWS engineers is to determine the parameters for the material model addressing the deformation as a function of the strain rate.

OUR SOLUTION

Flat tensile specimens were erosively cut from X39CrMo17-1 steel tubes. A special sample shape was selected with comparatively short parallel length.

Reliable data collection at high strain rates requires a strain sensor for dynamic experiments using a servo hydraulic tensile-testing machine. This machine was used to test numerous samples. The experiments were computer controlled. The strain rates ranged from $\dot{\epsilon} < 1 \cdot 10^{-3} \text{ s}^{-1}$ to $\dot{\epsilon} > 5 \text{ s}^{-1}$. Each test involved at least three tensile strain tests to provide sufficient statistics.

The tests yielded tensile strength data, which clearly showed the influence of the strain rate on the deformation behavior. With increasing strain rate the tensile strength R_m rose, whereas the uniform strain A_g decreased. Further data processing converted the technical stress-strain diagrams to true stress-strain flow curves with about 30 data pairs per curve. The data were then used as the basis to adjust the parameters in the Hensel-Spittel material model.



RESULTS

The Hensel-Spittel material model describes the relation between yield stress σ_w and a true strain ϵ_w with the equation:

$$\sigma_w = A \cdot \epsilon_w^{a_1} \cdot e^{a_4/\epsilon_w} \cdot \dot{\epsilon}^{a_2} \cdot e^{-a_3 \cdot T}$$

This equation includes the five material parameters A , a_1 , a_2 , a_3 , a_4 , and the strain ϵ_w , the temperature T and the strain rate $\dot{\epsilon}$ as independent variables.

Since the strain tests are performed at room temperature, adjusting the model is reduced to curve fitting with two independent variables and four parameters. The fitting of these model parameters was iteratively performed using analytical software. The results in comparison to the measurements are shown in Fig. 3. The good results

prove that the parameters are useful to describe the real deformation behavior of X39CrMo17-1. These parameters are used at Fraunhofer IWU Chemnitz in multistage simulations of forming processes of thick-walled tubes. Using the simulation models minimizes the number of costly forming experiments required to develop manufacturing technologies for valve sleeves.

- 1 *Servo hydraulic tensile testing machine with high strain rates*
- 2 *Strain test sample with fast strain sensor*

Stress-strain plots for different strain rates (comparison of the Hensel-Spittel model (line) with experimental data (dots))

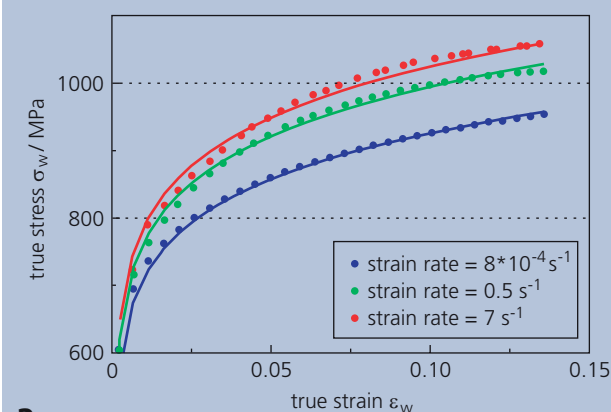

CONTACT

Dr. Gunter Kirchhoff
 phone: +49 351 83391-3225
gunter.kirchhoff@iws.fraunhofer.de





IN-SITU-CHARACTERIZATION OF THE DAMAGE EVOLUTION DURING HIGH FREQUENCY FATIGUE TESTING

THE TASK

In recent years the topic of fatigue behavior of metallic materials at very low amplitudes and as a consequence of very high cycles numbers (Very High Cycle Fatigue = VHCF) has become a significantly interesting topic and is gaining more and more attention from industry. In order to realize an utmost exploitation of the lightweight potential of modern materials an efficient design process of components and structures has become increasingly decisive. One of the principal questions is the minimum tolerable safety factor that still guarantees that a given defect size will not result in component failure.

In the past, loading amplitudes below a certain threshold value – the classical durability – were accepted as uncritical, assuming that those amplitudes do not contribute to any failure risks. However, latest research results could prove that even at amplitudes well below the classical durability fatigue cracks can initiate in defect-afflicted components and may propagate, provided the applied number of cycles is high enough. A particular challenge in this respect is introduced by the fact that crack initiation in the VHCF regime often relocates from the surface to the subsurface area of a fatigue sample or component.

In order to be able to detect crack initiation arising from internal defects or microstructural inhomogeneities at an early stage and to quantitatively describe crack growth, an in-situ-characterization of the damage evolution during high frequency fatigue testing is necessary.

OUR SOLUTION

IWS scientists have different measuring principles and devices at their disposal which can be used in combination with high frequency fatigue testing for an in-situ-damage monitoring. One of the major advantages of resonance pulsation test systems (Fig. 1) is the possibility of a very early detection of fatigue crack initiation by registering changes in the resonance frequency. Even microstructural changes, preceding the actual crack initiation, can have a significant influence on the damping behavior of the fatigue sample resulting in a registerable change in the resonance frequency. Frequency recording can be combined with a thermographic monitoring (Fig. 2), permitting a localization of the crack initiation spot. Hence, the combination of these in-situ-detection methods can be applied not only for homogeneous but also for any inhomogeneous structures such as composite materials or coated samples.

An additional IWS alternative for early damage detection during cyclic loading is based on the inherent nature of the excitation principle of the ultrasonic fatigue testing system. The sinusoidal signal, introducing the mechanical vibration in form of an acoustic wave along the sample's longitudinal axis, results in the formation of higher harmonics due to the nonlinear material behavior deriving from its microstructural inhomogeneities. The frequencies of these higher harmonics are integral multiples of the basic oscillation and are registered online as feedback signals during ultrasonic fatigue testing. Crack initiation results in an increase of the second higher harmonic and can be transferred into a so-called nonlinearity parameter acting as criterion for damage accumulation.

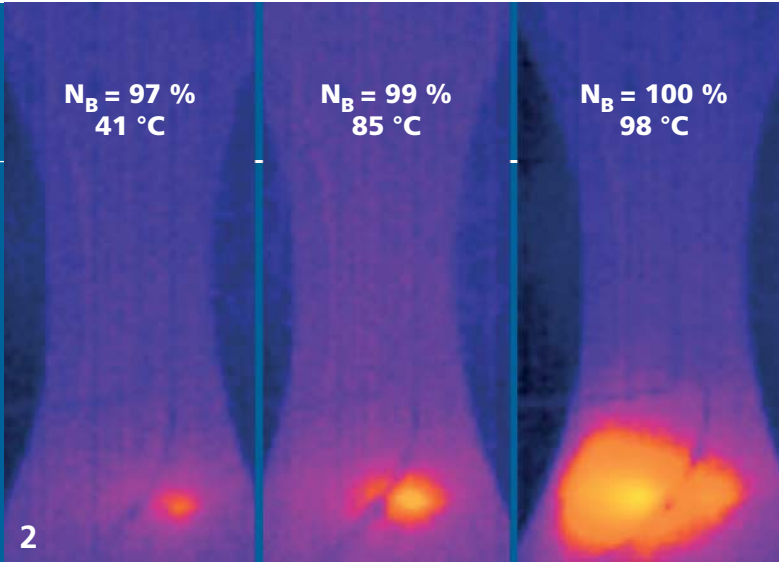

RESULTS

A reliable evaluation of defects and discontinuities is gaining importance with the increasing complexity of metallurgical and structural changes introduced by nowadays manufacturing processes. The necessary level of appropriate measures performed to ensure a fail-safe operation of safety relevant components strongly relies on this evaluation. As a consequence, the threshold value for failure-relevant defects versus still tolerable defects for the VHCF regime has to be determined carefully.

On the basis of fatigue tests carried out on aluminium welding samples significant discrepancies between the sensitivity of the earlier introduced in-situ-detection methods were observed. Analysis of the fracture surface of a fatigued sample revealed that the failure-relevant crack started from a hot crack, situated in the interior of the fatigue sample. The change in higher harmonics (in the diagram presented by the slope of the nonlinearity parameter over numbers of loading cycles) indicates a damage evolution at a very early stage of fatigue life. In contrast, the in-situ measured temperature and the resonance frequency do not show any significant changes until shortly before the overall failure of the fatigue sample.

Change of the resonance frequency, the nonlinearity parameter and the temperature during cyclic deformation of a welded fatigue test sample

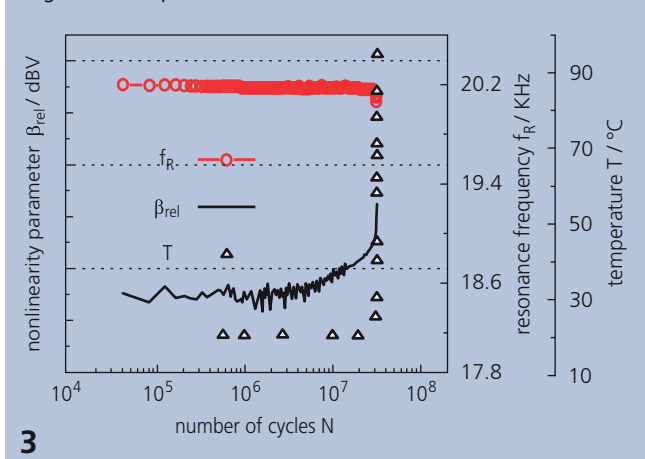

Fatigue tests carried out with the quasi defect-free base material showed that analyzed crack initiation was solely detected at the sample surface. In contrast to the welded samples, this time the earliest indication of damage evolution during cyclic deformation was given by an increase in the temperature while no significant changes in the resonance frequency or the higher harmonics could be observed.

The investigations demonstrate that the inherent signals of the high frequency fatigue testing systems based on resonance pulsation principles are well suited for an in-situ-characterization of larger, failure-relevant defects as can be found in inhomogeneous structures such as welded joints or composites. While changes in the damping and hence the resonance behavior of the fatigue specimen are reliable indicators of the point in time when the fatal damage evolution started, a thermographic monitoring during the cyclic testing permits a specification of the crack initiation spot. Hence, the measuring principles and devices available at the IWS are well suited for an in-situ-characterization of the early damage evolution during high frequency fatigue testing.

- 1 Resonance pulse test stand and infrared camera used for damage detection during high frequency fatigue testing
- 2 Locally measured maximum temperature observed during fatigue testing for a defect in the sample interior

CONTACT

Prof. Martina Zimmermann
 phone: +49 351 83391-3573
 martina.zimmermann@iws.fraunhofer.de



**HEAD OF DEPARTMENT
DR. ANDREAS WETZIG**



"You have to do something new to see something new."

Georg Christoph Lichtenberg



BUSINESS UNIT ABLATION AND CUTTING

Editor: Dr. Wetzig, Fraunhofer's central research focus is always linked to the application with the goal to generate innovations. Considering this, what happened in your business unit during the last year?

Dr. Wetzig: Ideas and inventions only promote innovations if they are implemented in new products and processes and actually successful in the market. Accordingly, I am proud that we managed this year to have driven a true innovation to market. In collaboration with German industry partners we implemented a fiber laser based process to improve the properties of grain-oriented magnetic sheet steel. These electrical sheets are used overseas for building transformers.

The process of laser magnetic domain refinement reduced the losses in transformers. For the first time a fiber laser is used, which simplifies the system. The application of the fiber laser also improves the process by further reducing the losses by 15 % compared to 10 % achievable with CO₂ lasers.

Editor: Today's ideas are tomorrow's innovations. What are the new ideas in the area of laser material processing of magnetic materials?

Dr. Wetzig: Currently we are working on the next step to extend the application of this technology for electrical sheets in motors and generators. However, these magnetic materials have a different structure, which is non grain-oriented. Therefore they differ in magnetic properties and the process

transfer is not one-to-one. Laser treatment of these non grain-oriented sheets leads to advantages, which depend on the operating point of the specific motor. In the case of high performance drives that operate at high speeds, the achieved loss reduction is a few percent. For high torque electrical drives the loss reduction can be as high as 5 %.

Editor: Process developments and subsequent system implementations are a particular strength of your business unit. Do you have more examples for system developments that are based on laser processes?

Dr. Wetzig: One of the many developments is the highly dynamic FormCutter, in short HDFC. This system was developed based on the technical potential of modern solid-state lasers, which enable the high cutting speeds.

Sometimes it is just the other way around; an in-house developed system technology enables a new process development. Nice examples originated from our research in micro technology. Our application-focused research in the area of THz technology created the necessary prerequisites to perform the current research on detecting biocides. Another example is the research into universal Lab-on-a-Chip platforms. These results open up completely new possibilities for red, white, gray and green biotechnological research not only for us but also for our industrial and scientific partners.

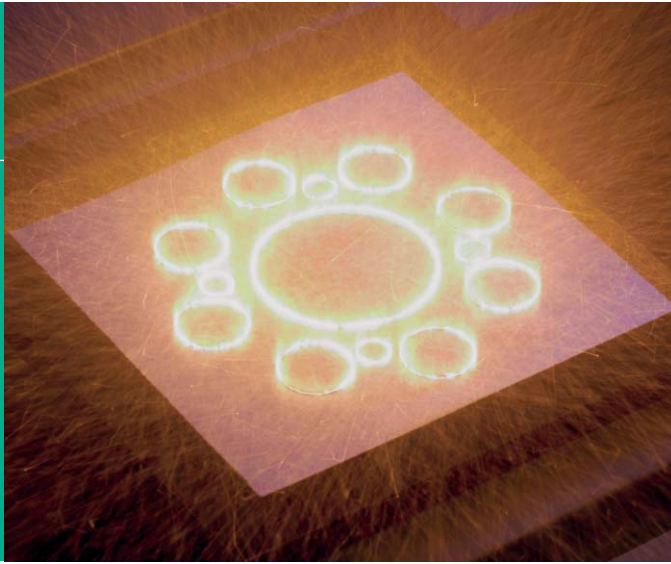

COMPETENCES

HIGH SPEED LASER PROCESSING

Our research addresses the development of process and system technologies for high-speed applications. A detailed process understanding is the basis for the successful industrial implementation of the technology. Our solutions offer the highest processing speeds. The spectrum includes remote welding, cutting and surface treatment processes for metals and non-metals. It also covers the development, setup and qualification of highly dynamic processing systems. A wide range of scanner system technologies is available, which is partially developed in-house and can be customized to meet the needs of our clients.

CUTTING

The group focuses on process developments in the field of laser fusion cutting. Topics include, for example, the improvement of the cutting quality with solid-state lasers or the optimization of electro metal sheet laser cutting without affecting the magnetic properties of the material. Another area is the qualification of novel cutting processes such as the remote laser cutting for manufacturing integration. To meet the various requirements we have a wide range of modern laser sources at our disposal.

MICROPROCESSING

An extensive and modern equipment pool and the associated know-how enable us to perform research for laser beam micro processing applications. The purpose is the miniaturization of functional elements used for the design of machines, plants, vehicles and instruments as well as in biological and medical products. Examples are the generation of 3D structures in the sub-mm range and of surface structures in polymers, metals, ceramics or quartzitic or biocompatible materials as well as laser cleaning technologies.

SURFACE FUNCTIONALIZATION

The group fabricates 2- and 3-dimensional micro- and nanostructures on polymers, metals, ceramics and coatings. New methods generate structures spanning macroscopic dimensions and yet provide micro- and nanoscopic properties over large areas. In addition to modifying topographies, it is also possible to periodically change the electrical, chemical and mechanical properties. Such structured surfaces can be used in biotechnology, photonics and tribology. Furthermore the group focusses on the development of system concepts for large area processing, including the required processing heads.



**GROUP LEADER
HIGH SPEED LASER PROCESSING**

DR. JAN HAUPTMANN
phone +49 351 83391-3236
jan.hauptmann@iws.fraunhofer.de



**GROUP LEADER
CUTTING**

DIPL.-ING. PATRICK HERWIG
phone +49 351 83391-3199
patrick.herwig@iws.fraunhofer.de



**GROUP LEADER
MICROPROCESSING**

DR. UDO KLOTZBACH
phone +49 351 83391-3252
udo.klotzbach@iws.fraunhofer.de



**GROUP LEADER
SURFACE FUNCTIONALIZATION**

PROF. ANDRÉS-FABIÁN LASAGNI
phone +49 351 83391-3007
andres-fabian.lasagni@iws.fraunhofer.de



HEAD OF DEPARTMENT

DR. ANDREAS WETZIG
phone +49 351 83391-3229
andreas.wetzig@iws.fraunhofer.de



2014 PROJECT EXAMPLES

- | | |
|---|----|
| 1. Optimal path control with superimposed axes systems | 72 |
| 2. Laser remote cutting of high porosity metals | 74 |
| 3. Large area micro structuring of transparent materials | 76 |
| 4. Structuring surfaces faster, more accurately and less costly | 78 |
| 5. Camera assisted laser remote processing for the precision cutting of fiber reinforced polymers | 80 |
| 6. Multilayer microfluidic to cultivate kidney cells | 82 |
| 7. Optical diode for multi-kilowatt laser applications | 84 |
| 8. Higher flexibility with dual core fibers | 86 |



OPTIMAL PATH CONTROL WITH SUPERIMPOSED AXES SYSTEMS

THE TASK

The path control system in conventional laser cutting machines is the dynamics limiting factor when cutting metal sheets of up to 2 mm thickness. The cutting of filigree patterns with many directional changes keeps the axes in a state of continual acceleration and deceleration. The achievable cutting speed therefore falls far behind the technical possibilities of the laser.

Increasing the average processing speed requires a machine with higher dynamic limits. One possible solution is to add a highly dynamic secondary axes system, which is superimposed to the primary system but covers a much smaller working field. The primary axes system controls the relative motion between the workpiece and the secondary system. The secondary system moves the laser beam at much higher speeds.

The key task during the implementation of superimposed axes systems is the development of the path control algorithm. The laser beam path along the desired contour has to be calculated as a superposition of the paths of primary and secondary axes systems.

OUR SOLUTION

Several path planning tools are available at Fraunhofer IWS for coupling axes mechanisms. CAD data are combined with process parameters and operating strategies. Path calculations for primary and secondary axes systems consider the overall system model, which includes the dynamic parameters of the axes. The calculations can be performed offline. The data file is then transferred to the machine controller to execute the path. It is also possible to online perform calculations at the control computer.

Offline calculations have the advantage of using greater computational resources to optimize the paths. Possible optimization criteria include minimum processing times and minimum energy consumption of the system. Parameters such as maximum values for jerk, acceleration and velocity of primary and secondary axes are always considered during the optimization calculations.

A test stand was developed to implement these strategies (Fig. 1). The secondary axes system is the highly dynamic form cutter HDFC₆₀₆₀, which can process a working field of 60 x 60 mm². The form cutter is mounted to a fixed bridge carrier. The primary axes system is a cross table that moves the workpiece. The HDFC₆₀₆₀ has a very stiff axes structure, low moved masses, a small working field and is fully equipped with linear direct motors. The combination of these factors leads to up to ten times higher accelerations. The maximal acceleration of the HDFC₆₀₆₀ is 30 m/s².



RESULTS

Fig. 3 shows a sample contour to calculate the paths for primary and secondary axes. In this case the goal was to minimize the processing time and energy consumption of the entire system.

The optimized solution is also shown in Fig. 3. The blue curve represents the primary path, which is essentially the path of the working field center point of the secondary axes system. The secondary axes system then corrects the laser path to eliminate the differences between primary axes system path and desired cutting path.

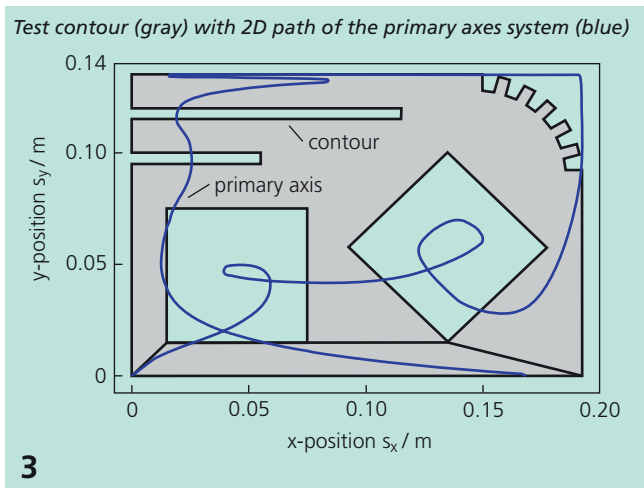

The timing of the laser beam motion relative to the contour as well as primary and secondary axes is plotted in Fig. 4. The full dynamic potential of the axes configuration is exploited to minimize the processing time. Accelerations at the workpiece reach 40 m/s^2 . The total jerk is 1500 m/s^3 (combined primary and secondary axes jerks). The superimposed axes systems achieve a 45 % reduction in processing time compared to the conventional process that uses only one axes system.

The goal of minimizing the overall energy consumption is partially achieved as a consequence of the minimized processing time. However, other degrees of freedom during path planning are applied to minimize the energy losses of the drive system as well.

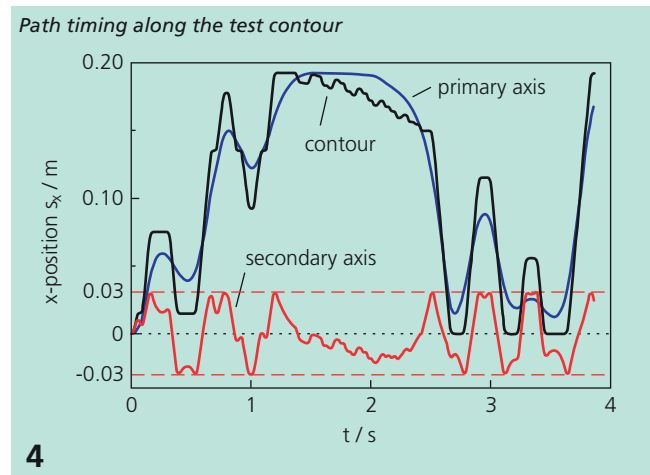

- 1 *Highly dynamic form cutter HDFC₆₀₆₀ in combination with x-y table*
- 2 *Laser beam cutting with overlaid axes system*

CONTACT

Dipl.-Ing. Frederik Klenke
 phone: +49 351 83391-3418
 frederik.klenke@iws.fraunhofer.de





LASER REMOTE CUTTING OF HIGH POROSITY METALS

THE TASK

Manufacturing costs, safety and efficiency aspects are some of the main topics worked on in the field of modern battery research. One of the goals is to achieve a higher volumetric efficiency. Porous open cell metal foams are a new class of materials of interest to battery designers apart from traditionally used foils. These metal foams vary in materials (nickel, Inconel, aluminum, copper, titanium), porosity and thickness.

An important aspect is the cutting of the anodes and cathodes. Currently mechanical cutting processes (punching, grinding, milling) are mainly used. However, issues such as high tool wear, partial clogging of the pores and crushing of the workpiece edges pose serious challenges, making these processes inefficient. In addition, manufacturing lot sizes are decreasing and increase the need for flexible cutting processes that can be easily adjusted for cutting different contours. The open cell metal foams may also be coated or filled with materials that react with oxygen. Therefore processing of such foams requires an inert environment.

The task is to cut these foam materials without affecting their function and without damaging them at the cutting edges. Conventional gas assisted laser melt cutting is not suitable. Melt cutting relies on the buildup of a sufficiently high pressure to eject the melt from the cut. At porosities exceeding 90% such pressure is not generated. Subsequently metal droplets stick to the cutting edge, which could damage ceramic separators in the batteries and cause cell failures.

In addition to quality concerns the cutting speed is crucial. Gas assisted laser melt cutting requires heavy processing heads. The associated inertia limits the cutting speed. New approaches are required to solve this task.

OUR SOLUTION

Fraunhofer IWS engineers developed processes to cut porous metal foams using high speed beam deflection systems in combination with high brilliance solid state lasers. The results clearly improved the cut quality. This laser remote cutting process uses two mirrors, which quickly scan the beam and focus it onto the material surface by means of a F-Theta objective. The mirrors are of light weight and moved by galvanometers. The path velocities can exceed 10 m/s and accelerations are as high as several 10 g. The beam path remains very precise despite such high speeds.

The short interaction times in combination with extremely high intensities cause mostly evaporation in the cut volume. Material damaging heat transfer is much lower compared to conventional gas assisted laser cutting.

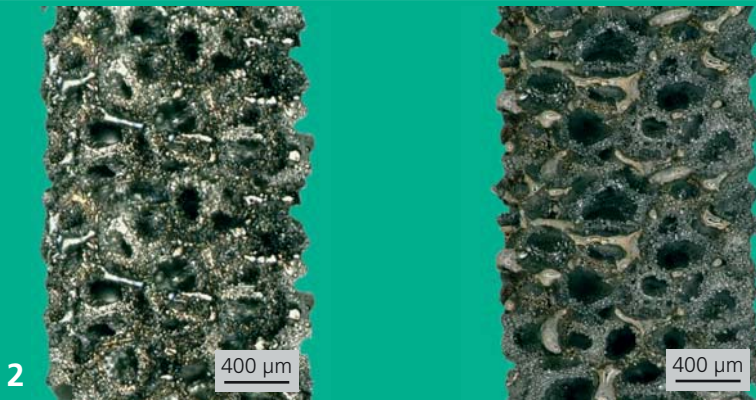

RESULTS

The investigations showed successful separation of porous metal foams with laser remote cutting. Thermal damage at the edge is less than 50 µm. Clean cuts were obtained for any material combination.

The material removal per cut with high brilliance solid-state lasers in the kW power range is 20 - 50 µm. Several runs are required to cut through millimeter thick material. However, due to the high scanning speeds the laser remote cutting process is still 3 times faster compared to conventional cutting.

Fig. 2 shows the view of cut edges from 2.6 mm thick metal foam sheets made of Inconel. The left sample was cut using laser remote cutting and the right sample is the result of conventional gas assisted laser cutting. The latter sample shows large melt agglomerates on the edge whereas no droplets can be found at the edge prepared by laser remote cutting.

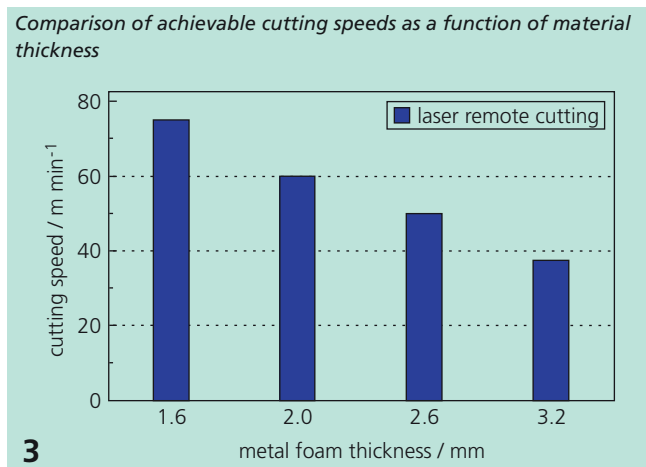

Fig. 3 plots the cutting speed versus metal foam thickness. As evident from the data, the laser remote cutting process has a clear advantage over the conventional process, which even further increases with thicker sheets.

Laser remote cutting meets the requirements for battery fabrication with respect to quality and productivity.

- 1 *Inconel foam in original form, 450 µm pore size*
- 2 *Inconel foam, left: laser remote cut, right: laser melt cut*

CONTACT

M.Eng. Robert Baumann
 phone: +49 351 83391-3423
 robert.baumann@iws.fraunhofer.de





LARGE AREA MICRO STRUCTURING OF TRANSPARENT MATERIALS

THE TASK

Building complementary functions into single objects is certainly appreciated by the end user but also poses an interesting task for designers and manufacturers. The field of functional lighting offers a variety of intriguing concepts. Lights have to be designed to fit a certain shape and to illuminate the desired area according to color and brightness specifications. They also have to meet mechanical stability specifications, need to be energy efficient and should be free of maintenance requirements. And finally they should have an attractive design.

An interesting task was the development of a lighting solution for luggage racks in trains. The solution had to combine spot and area illumination with the requirement for safe luggage storage. The concept was to have a transparent and large area self-illuminating luggage rack, which offers the traveler a selectable choice of lighting conditions. This thrilling idea implies a number of challenges for the manufacturer. For example, LED spotlights have to be integrated as well as OLED area lighting. The necessary electrical pathways must be invisible so that the luggage can be seen without impairment.

A possible solution is based on using panes of glass coated with transparent conductive oxides (TCO). The dimension of a self-illuminating luggage rack is 1 m x 0.4 m. The task is to structure the TCO layers providing safe power to all electrical components while avoiding parasitic leakage currents.

The separation of the conducting paths in the TCO coatings should be invisible and not damage the glass substrate. A luggage rack consists of two glass panes, which are bonded together by a polyurethane foil via hot pressing. This foil has to be structured as well to work for the lighting design.

OUR SOLUTION

The selective structuring of a transparent coating on a transparent substrate is in itself challenging. The approach is to use short pulsed UV and ultra-short pulsed IR laser radiation. Both offer excellent depth control of the ablation process. The absorption of the TCO coating is higher than that of glass in the UV and IR spectral ranges, which benefits this process.

An additional aspect is the need for creating most accurate microscopic structures across a large area. Typical process areas for laser micro machining systems are about 100 x 100 mm². Approaching this challenge by stitching smaller sections to cover the large working areas is limited due to optical pincushion and barrel distortions. Such distortions cause disruptions in the areal coverage leading to malfunction.

A new micro structuring machine was used to overcome these issues. This machine has ultra-accurate axes systems with enormously precise scanning field correction (Fig. 2).

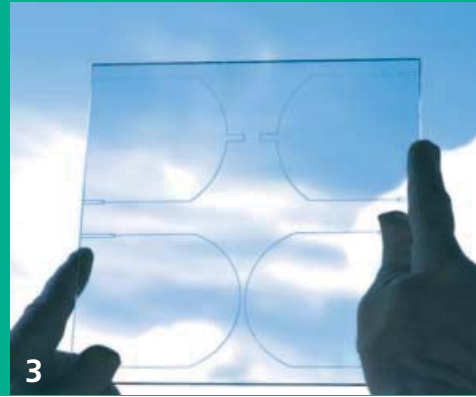
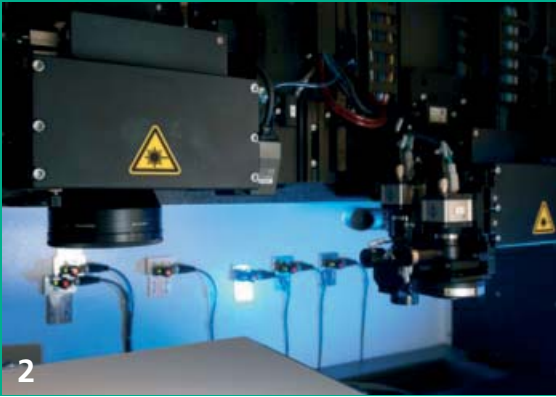

RESULTS

The feasibility of the laser processing approach was demonstrated first with smaller samples. A short pulsed nanosecond laser of 355 nm wavelength was applied to electrically disconnect TCO areas, which can conduct electricity to an LED (Fig. 3).

Even better results were achieved with the ultra-short pulsed picosecond laser at 1064 nm wavelength. Skillfully selected laser parameters lead to a complete removal of the TCO along the desired path without any damage done to the glass substrate. Therefore it was decided to use this laser when transferring the process to the final dimensions of 1 m x 0.4 m.

The complete structure had to control 6 OLED areas and 2 spotlight LEDs. The first step was to obtain the exact position of the glass pane. Then the complete structure was laser-machined by stitching together a total of 40 100 x 100 mm² segments. This way it was possible to structure the first 50 % of the area of the glass pane. Then the pane was rotated 180° and realigned to process the remaining segments.

The processing of the adhesive polyurethane foil followed the same principle. The objective is to cut out sections for areal and spotlights. To create an eye-catching design element the partner's company logo was machined into the center part of the TCO coating.

The laser track width is only 40 µm but it was sufficient to completely separate the TCO coating across all contour segments. This was also verified and documented by inspecting the sections with a microscope.

Traditionally "micro structuring" and "accuracy over large areas" are mutually exclusive constraints. However, this project demonstrated that both objectives could be simultaneously achieved. Combining process and systems know-how made it possible to create almost invisible functional structures in transparent coatings on transparent substrates.

- 1 *Large area laser micro-structured TCO coated glass substrate*
- 2 *Micro structuring system with two scanner heads to process large workpieces*
- 3 *UV laser structured surface for feasibility testing*

CONTACT

Dipl.-Ing. (FH) Thomas Kuntze
 phone: +49 351 83391-3227
 thomas.kuntze@iws.fraunhofer.de





STRUCTURING SURFACES FASTER, MORE ACCURATELY AND LESS COSTLY

THE TASK

Micro- and nanostructures improve mechanical, biological and optical surface properties, which can be tailored to customer requirements. Prominent examples in nature are moth eye structures with anti-reflective properties or shark skins with advantageous tribological properties.

Mimicking such structures is pursued with different technologies. However, nature-inspired biomimetic surfaces are hard to find in everyday life. Many examples could be shown demonstrating this function, however, conventional technologies are too expensive to create micro- and nanostructures across large areas or the surfaces of 3D parts. Often the desired structure sizes and achievable throughputs did not meet industrial requirements.

OUR SOLUTION

Direct laser interference patterning (DLIP) is a technology making a significant step forward toward the goal of reducing processing times at higher resolutions and to lower system costs (Fig. 2).

The DLIP technology splits the coherent laser beam in two or more partial beams and superimposes them on the substrate surface. The superposition modulates the laser intensity across the surface, which is exploited to create patterns (Fig. 3). A single laser pulse can structure areas from a few micrometers to several centimeters with periodic micro- or nanosized patterns.

In recent years Fraunhofer IWS engineers have researched the suitability of the DLIP process for industrial applications. The work aimed at miniaturizing and optimizing the optical components for beam splitting and superposition and to develop a compact laser processing head. The DLIP processing head was then integrated into various laser materials processing machines (e.g. Fig. 1) to demonstrate the flexible and cost effective patterning of surfaces with periodic structures of micron and submicron dimensions.

Comparison of processing speeds of different surface patterning technologies.

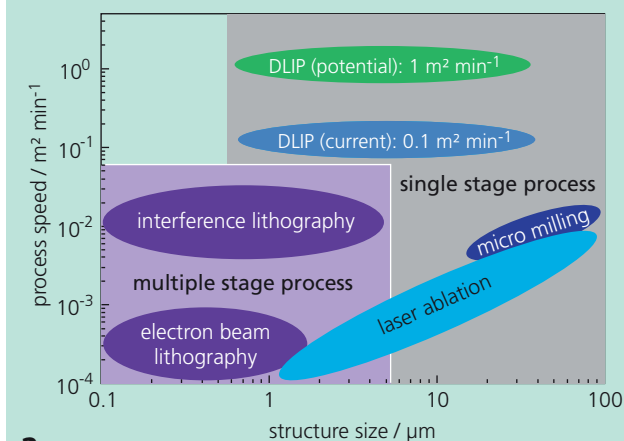



3

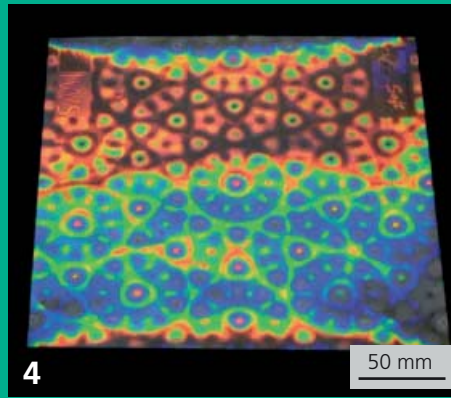

4

RESULTS

Fraunhofer IWS offers application-tailored processing optics and complete DLIP processing machines including the necessary lasers. These systems are highly automated and intuitively usable (Fig. 5). The system shown in Fig. 1 offers the following features:

- compact design (l x w x h: 1 x 1 x 2.5 m³),
- integrated laser beam source (ps or ns laser),
- variable structure sizes from 0.5 to 5 μm,
- software controlled structure size,
- structuring speeds up to 1 m²/min,
- sample sizes of up to 500 x 500 mm²,
- certified as Laser Class 1 system.

The Fraunhofer IWS offers the powerful laser system DLIP-μFab for laser surface patterning. The system is modular so that it can be configured to meet the requirement of a broad range of possible applications. Laser sources, CNC axes systems and highly precise granite supports can be selected. Even very challenging tasks can be performed with the system, e.g., patterning with feature sizes smaller than 500 nm or processing speeds exceeding 1 m²/min.

It is also possible to use the DLIP optics for the cost effective processing of roll-to-roll material, 3D workpieces and surface areas exceeding 1 m².

Software tool for DLIP system control and transfer of bitmap images



5

- 1 DLIP-μFab processing system with DLIP optics (blue) in center
- 3 DLIP structured steel sample
- 4 Structured nickel foil with large area hologram

The systems are designed for wavelengths in the IR, Vis or UV ranges. IWS engineers develop novel beam guiding concepts to automate the variation of structure sizes (interference periods).

DLIP is suitable to pattern metals, ceramics, polymers and coatings in a single process step with periodic micro- and nanostructures.

CONTACT

Dr. Teja Roch
 phone: +49 351 83391-3083
 teja.roch@iws.fraunhofer.de



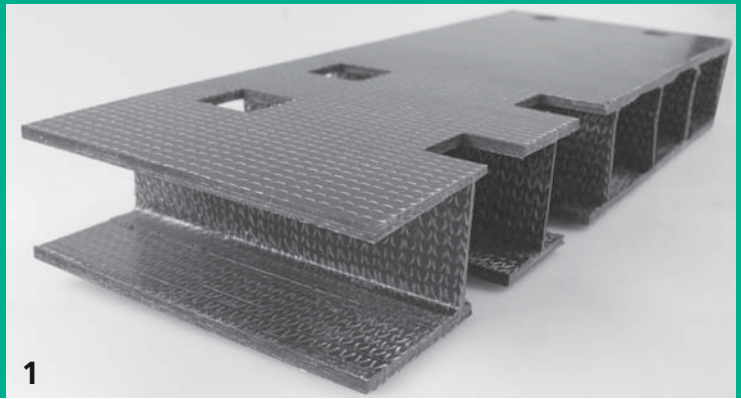

CAMERA ASSISTED LASER REMOTE PROCESSING FOR THE PRECISION CUTTING OF FIBER REINFORCED POLYMERS

THE TASK

Fiber reinforced polymers were first applied in the aerospace industry. Meanwhile they are established high performance materials for many applications. Optimized fiber placing methods such as multilayer knitted fabrics or tailored fiber placement structures make it possible to efficiently use the reinforcing glass and carbon fibers. In addition to orienting the fibers to suit the load bearing requirements, these textile fabric structures more efficiently utilize the fibers and help to reduce scrap from offcuts and thus make better use of resources.

Highly flexible fiber placement capabilities support the generation of parts of greater complexity. However, these parts in turn require complex post-processing and finishing steps. Conventional methods such as water jet cutting and milling are subject to wear. The structural strength of fiber reinforced polymers often requires larger processing forces, which reduces feeds and processing speeds. Improving and optimizing these steps are challenges which can be addressed by using laser technology.

A condition for reproducible laser cutting is an accurate alignment of the part. In addition to using brilliant laser sources and high feeds the precise positioning of the part is critical to minimize thermal damage to the composite.

OUR SOLUTION

Fraunhofer IWS engineers developed a camera assisted laser remote cutting system (remocut[®]VIS) for the post-processing of fiber reinforced polymers. During processing quickly moving mirrors guide the laser beam following the desired contour. The dynamics of the process minimizes the interaction between laser spot and part, which reduces the thermal decomposition of the polymeric matrix. Fiber reinforced polymers are cut with good quality and productivity.

The newly developed opto-electronic module remocut[®]VIS adds to IWS's remote processing systems technology. A high-resolution camera is coaxially aligned with the laser beam to accurately identify the part position. The system recognizes part shapes as well as fiber orientation. The data are used to optimize the cutting path. The system captures the manufacturing tolerances of previous processes and adjusts the cutting contour accordingly.

Remocut[®]VIS also offers the option to generate the cutting path based on images.

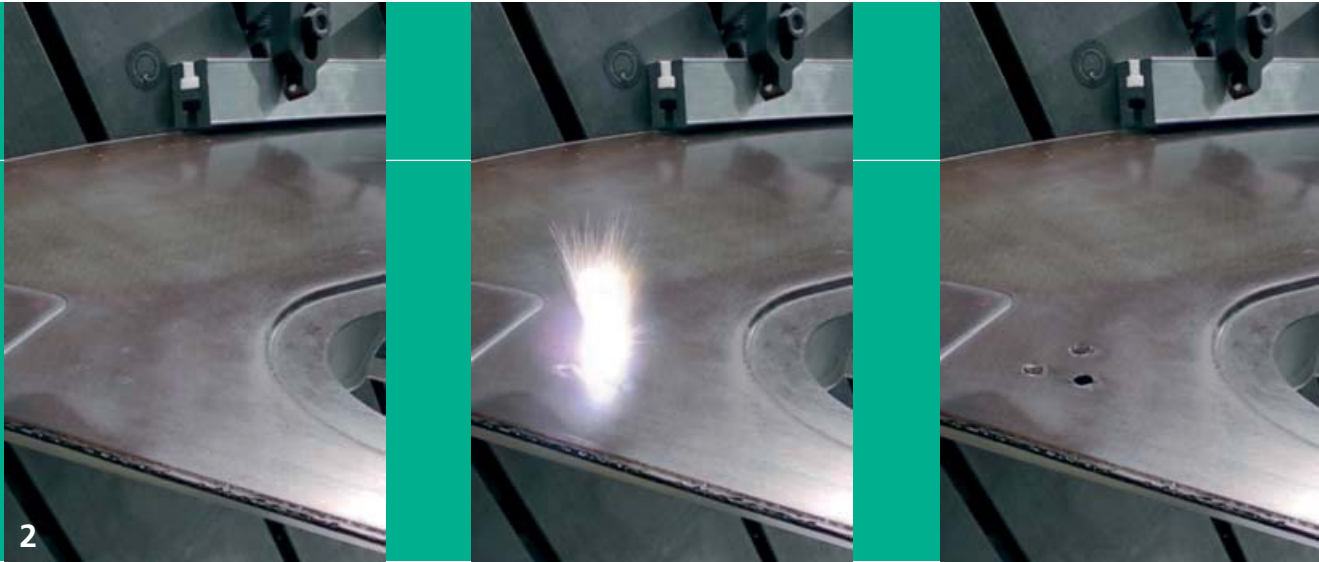

2

RESULTS

The textile-conform positioning reduces the interaction time between laser beam and material and improves the cutting results. The remocut[®]VIS technology generates material-conform cuts at minimized thermal damage.

In the case of processing voluminous consolidated workpieces the remote system can be used with industrial robots. The camera module teaches the system the processing positions (Fig. 2).

Additional applications were evaluated within a special research project SFB 639 at the TU Dresden. Cutting tests were performed with glass fiber polypropylene roved multilayer knitted fabrics. The goals were to create openings in consolidated parts and to trim the edges.

Remocut[®]VIS digitizes the contours for the sensor element that is to be embedded into the fiber reinforced structure. From these data the system calculates the laser cutting paths. The cuts for the polypropylene knitting fiber (yellow) and the glass fiber roving (blue) are marked in Fig. 3b. Processing parameters are defined with the developed CAD/CAM software following the desired material removal strategy. Finally the knitting and roving fibers are cut with adjusted parameters (Fig. 3 c).

- 1 *Spacer fabric, based on multilayer knitting*
- 2 *Technology demonstration with a helicopter door*

Twintex[®] multilayer knitted fabric to integrate sensor components

a) contour recognition of the sensor element to be embedded



b) generated power variable laser cutting path

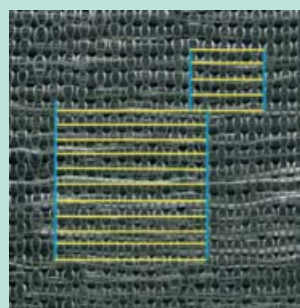

c) formed pocket

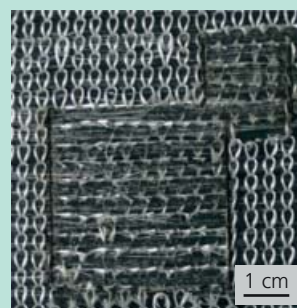

3

CONTACT

Dipl.-Ing. Andreas Fürst
 phone: +49 351 83391-3544
 andreas.fuerst@iws.fraunhofer.de



MULTILAYER MICROFLUIDIC TO CULTIVATE KIDNEY CELLS

THE TASK

Germany's changing demography and kidney insufficiencies of people over 60 has led to a continual increase of the number of patients with kidney diseases. In parallel the number of patients requiring dialysis due to kidney failures rises. The large number of patients with kidney insufficiencies shows the need for improved dialysis methods and systems to support residual kidney functions.

Currently there are no systems available that support residual kidney functions or that can be implanted to partially or completely replace the kidney. The only option is dialysis, which reduces the quality of life. There are about 6000 people, waiting for organ donations. Artificial organs or technical kidney replacement devices would be promising alternatives.

OUR SOLUTION

So far the potential of modern microfluidic organ replacement systems has been unused. This technology can build multilayer organoids of the size of a credit card that can flow liquids and simulate the function of miniaturized replacement organs. Capillary structures can be freely placed and connected by membranes to simulate the selective exchange of substances similar to the human body.

Such microfluidic systems offer the possibility to study complex cellular interactions and to modulate them. Guidelines can be developed for optimum cellular interactions in multidimensional systems.

The fast, flexible and cost effective fabrication of Lab-on-a-Chip systems is performed at Fraunhofer IWS. The institute has a special manufacturing technology to assemble multilayers of laser microstructured foils. To build a specific microfluidic system the first step is to slice the design into individual layers. Each slice is then created as a separated foil or plate.

Microfluidic system in multilayer design

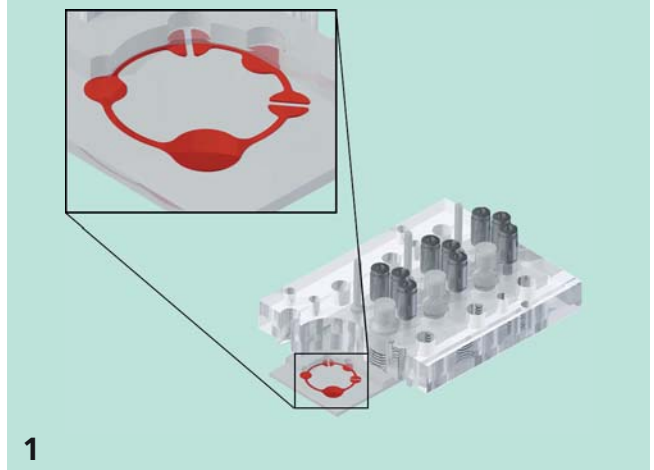

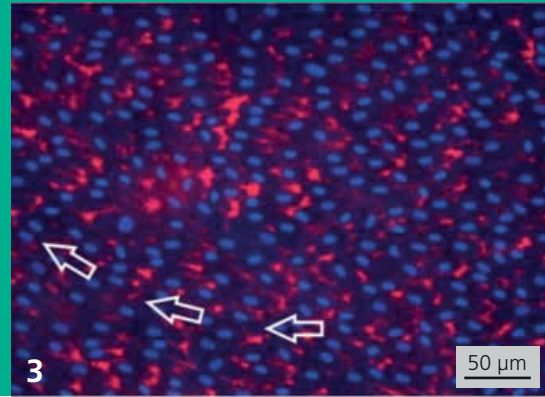
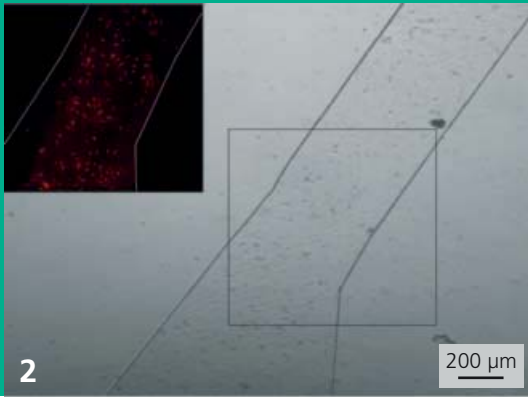

The next step is to select the application-dependent properties for each individual layer (hydrophilic, hydrophobic, transparent, permeable, porous). The third step is to structure and functionalize the plates and foils on both sides using laser micro materials processing. Finally the individual layers are connected via adhesive, plasma or thermal bonding, (pages 118/119).

RESULTS

Fraunhofer IWS engineers have developed a prototype Lab-on-a-Chip system to simulate the capillary flow conditions in a kidney. The system contains 4 parallel circuits with smallest channel volumes of 40 μl . This minimizes the number of cells in the microfluidic systems and keeps the costs for the experiments very low.

A kidney capillary was simulated by complete endothelization meaning the growth of a complete layer of endothelial cells on the inside walls of the system. Primary human endothelial cells were used from an umbilical cord (HUVEC). Perfusion led to cell alignment similar to that observed on the inside walls of human endothelia.

The developed system is used to study the interaction of kidney endothelial cells with leukocytes or thrombocytes. The goal is to find root causes and treatment options for various degenerative kidney diseases.

- 2 *Brightfield image of HUVEC covered channel one day after perfusion, the cells were vital stained with a red fluorescing dye (section)*
- 3 *Brightfield image of double fluorescently stained cells under perfusion (blue: cell nuclei; red: surface marker of endothelial cells); the white arrows show the curved flow direction and the alignment of the cells*

CONTACT

Dipl.-Ing. Florian Schmieder
 phone: +49 351 83391-3520
 florian.schmieder@iws.fraunhofer.de





OPTICAL DIODE FOR MULTI-KILOWATT LASER APPLICATIONS

THE TASK

Laser cutting and welding processes are flexible and cost effective solutions for machining metal parts. The demand for processing copper is rising in parallel with the increasing demand for electric machines. However, copper reflects more than 95 % of the laser light generated by typical CO₂ or solid-state lasers, used for cutting and welding. Due to the reflectivity energy coupling is difficult and the large amount of reflected light also presents a danger to the lasers themselves.

There is a standard solution for CO₂ lasers that minimizes this risk. Modern solid-state lasers however are the better option to process reflective materials. A protective mechanism comparable to that available for the CO₂ laser does not exist for solid-state lasers. Commercially available solutions are based on measuring the reflected laser light and shutting off the laser in case of danger, which causes an undesired process stop. This method also does not prevent damage to the end of the delivery fiber (Fig. 1). In some cases the fiber gets completely destroyed. The task is to develop a protection mechanism that works similar to that available for CO₂ lasers.

OUR SOLUTION

The only known solution to protect the system from reflected laser radiation is based on exploiting the polarization of laser light. This method is not applicable for disk and fiber lasers as the beam sources and fibers have a statistical distribution of polarization states. Avoiding the risk of damaging the laser resonator and the delivery fiber requires a safe blockage between fiber and processing zones.

Fraunhofer IWS engineers developed modules and complete processing heads to accomplish this goal. Nonlinear optical retardation elements such as Faraday rotators create, similar to the CO₂ concept, a lambda/2 delay between incoming and reflected beam and decouple the reflected beam via a polarization based beam splitter into a beam dump.

The statistic polarization of current laser beam sources requires beam splitting, rotation of the polarization and beam recombination. The resulting beam with circular polarization is similar to that of conventional processing optics.

Implementing this concept requires special optical elements. These were specified by Fraunhofer IWS engineers and fabricated by suppliers and are now commercially available.

Optical diode for polarized laser radiation (left) and for statistically polarized laser radiation (right)

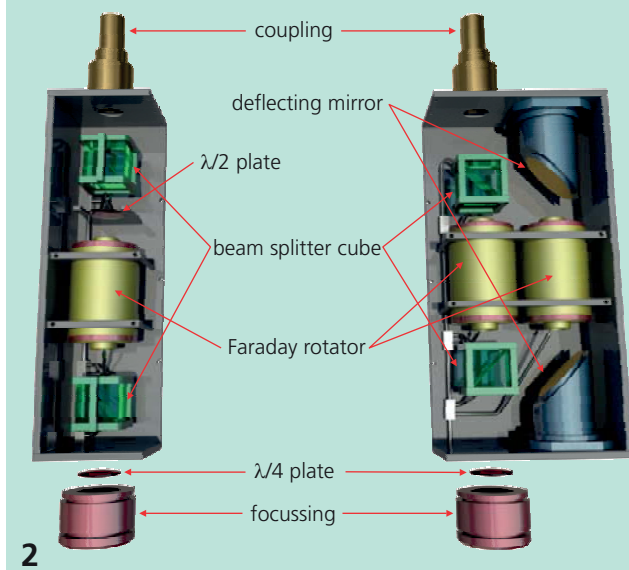

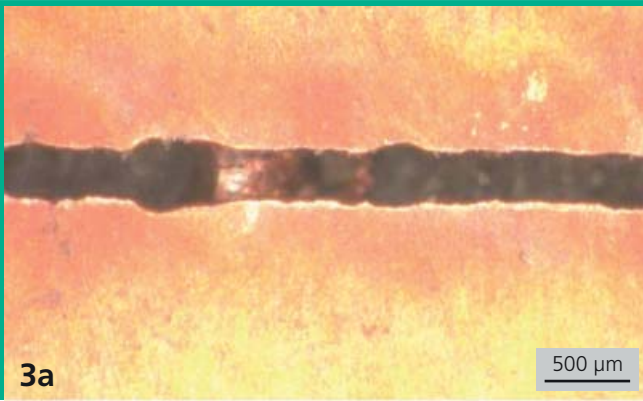

Faraday rotators, retardation plates and beam splitters are used to adjust the processing optics to the particular application (Fig. 2). Novel mechanical concepts are implemented to exactly adjust the partial beams of statistically polarized laser light. The adjustment is sufficiently accurate for diffraction-limited radiation so that there is no deviation detectable between the beam positions in the focus.

The commercial Faraday rotator concept is insufficient for diffraction-limited lasers with powers exceeding one kilowatt. The Faraday crystals absorb radiation and heat up. This results in undesired shifts of the focus position and unstable processing conditions. A completely new Faraday rotator concept had to be developed and tested (Fig. 4).

The geometry of the Faraday crystal was changed and in combination with active cooling on one side it was possible to achieve nearly linear temperature distributions in the crystal. Light passes twice through the crystal in different directions and thus compensate for the thermally induced shift of the focus position. This Faraday rotator is implemented in optical diodes so that multi-kilowatt diffraction-limited fiber lasers can be used.

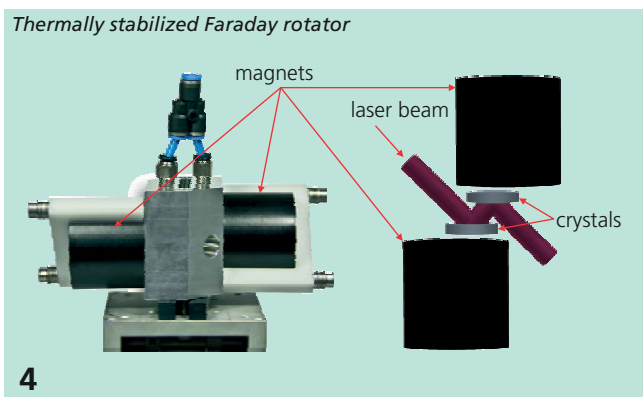

RESULTS

The processing heads (Fig. 2) were subjected to comprehensive testing. For example a test used permanent loads of 4 kilowatt laser power on a copper mirror representing an idealized processing zone. This puts an effective load of 8 kilowatts on the optical elements. The absorption of the laser power was measured with beam dumps. Beam diagnostics confirmed that the beam properties were maintained. The optics attenuates 20 dB clamping.

In field tests with copper it was impossible to trigger a failsafe shutoff of the laser. Without the diode such a shutoff would already occur with minimal process parameter deviations. With special parameter variations it is possible to determine the reflected power at the beam dump. Welding tests of copper contacts (Fig. 3) show the same results as obtained with processing heads without optical diodes. If mirrors are used instead of beam dumps it is possible to clearly improve the stability of welding and cutting process since the laser light gets immediately reintroduced to the processing zone.

- 1 Damaged fiber end due to back reflection
- 3 Cutting edge quality, using beam dumps (a) or mirrors (b)

CONTACT

Dipl.-Ing. Patrick Herwig
 phone: +49 351 83391-3199
 patrick.herwig@iws.fraunhofer.de





HIGHER FLEXIBILITY WITH DUAL CORE FIBERS

THE TASK

Service providers in the field of laser materials processing are assigned with different tasks such as laser cutting, laser welding and laser cladding. Also, in prototype production changes in production technology are often necessary. If ideal laser technology is used for each process this can be cost prohibitive. An efficient degree of machine utilization is not always possible. In fact state-of-the-art lasers offer the possibility to couple out of fibers with different fiber diameters but switching fibers frequently may cause contamination or damage of the fiber ends. A flexible machine concept is demanded which offers quick automatic changes of the fiber diameter as well as an automatic adjustment of the beam focus spot diameter.

OUR SOLUTION

The Fraunhofer CLA in Plymouth, MI, USA has put a new laser work station into operation which includes new dual core fiber technology. This 5-axis-CNC-laser work station offers a work

envelope of 4 m (13.1 ft) x 1.5 m (4.9 ft) and a motorized welding optic. It is the first of its kind in North America.

An internal laser switch automatically accomplishes changing from the inner 100 µm core fiber to the outer 400 µm fiber. Therefore a fast adjustment of the laser beam focus spot size for welding processes can be realized as well as a quick change from welding to cutting (and vice versa) without changing the actual fiber.

Principle of a dual core fiber

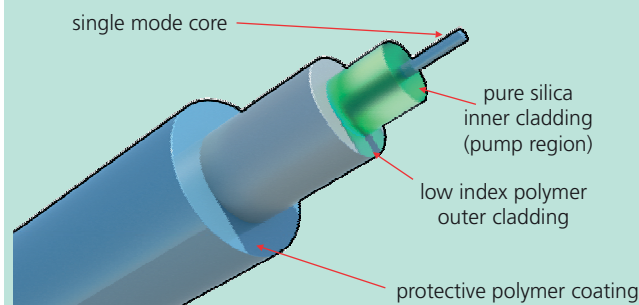

Technical data of the system

axis	work area	speed
X	4,000 mm	100 m min ⁻¹
Y	1,500 mm	80 m min ⁻¹
Z	750 mm	80 m min ⁻¹
B	± 120 °	60 min ⁻¹
C	n x 360 °	60 min ⁻¹
simultaneous	-	150 m min ⁻¹

accuracy	
smallest programmable measurement path	0.001 mm
max. spread, linear axes	0.03 mm
max. spread, rotation axes	0.005 °
max. positioning, linear axes	0.08 mm
max. positioning, rotary axes	0.015 °

TRUMPF TruDisk HLD6001	
max. laser power TruDisk	6,600 W
max. power for cutting	6,000 W



RESULTS

Figure 6 shows how the coupled laser beam is moved from the inner 100 micron core (left) to the outer 400 micron core (right) by using a wedge plate. Typically for laser cutting, the inner core is used and for laser welding the outer core is selected.

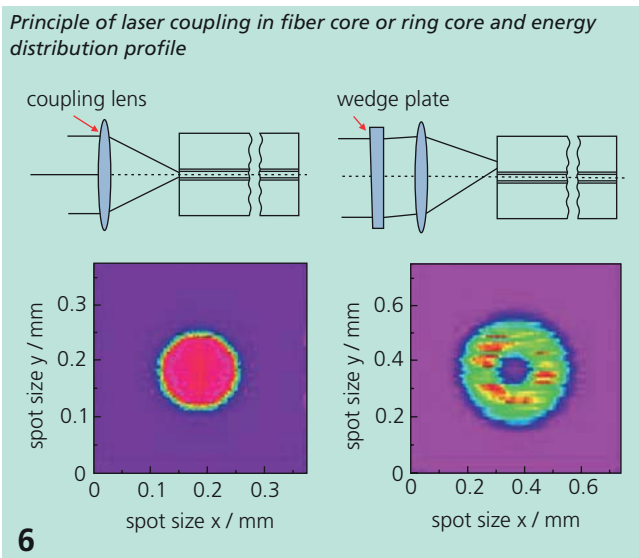

The motorized weld optic offers an additional adjustment of the spot size in the laser focus. Just by changing the settings on the CNC control panel, the spot diameter can range from 0.38 mm to 0.58 mm when using the 400 micron fiber and from 0.1 mm to 0.18 mm when using the 100 micron fiber.

Fraunhofer CLA has used the presented work station already in a variety of laser cutting and laser welding projects (see also fig. 1, 4, and 5) and significantly saved time between

changing over from one process to the other. Changing over is fairly simple and quickly accomplished and, therefore, demonstrates the potential for a reduction in efforts for service providers and prototyping job shops using this technology.

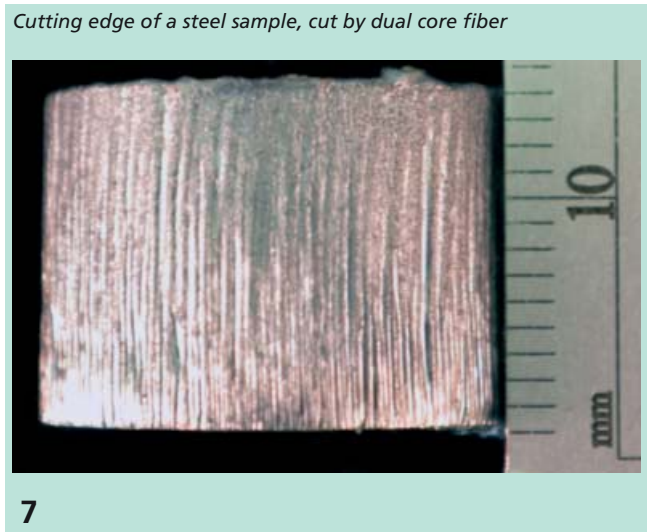

- 1** Laser welding process with integrated rotation axes
- 4,5** Laser cutting process with dual core fiber

CONTACT

Craig Bratt
 phone: +1 734 738 0550
 cbratt@fraunhofer.org



**HEAD OF DEPARTMENT
PROF. DR. ANDREAS LESON**



"The biggest mistake in life is being too afraid to make mistakes."

Dietrich Bonhoeffer



BUSINESS UNIT PVD VACUUM COATING TECHNOLOGY

Editor: EUV lithography is a promising technology for the fabrication of ever more complex integrated circuits. After some delays it is now certain that this technology will be used in future semiconductor manufacturing lines. Prof. Leson, which role does IWS play in this area?

Prof. Leson: X-ray optics is the key component. We have many years of experience and competence in the fabrication of extremely precise multilayer coatings. Thus we can provide important contributions to the production of such extraordinarily sophisticated optical systems for EUV lithography applications. There is still a high potential for improvement, which we will jointly exploit with our partners. A notable and particularly gratifying result of this year was that, thanks to new systems technology, we again scored a world record with the reflectivity of our multilayer coatings. This, once again, makes EUV lithography more productive. Our multilayer coating knowhow is also advantageous for other applications of high resolution X-ray optics such as multilayer Laue lenses. For the first time ever we managed to focus an X-ray beam to less than 45 nm by using crossed Laue lenses.

Editor: The manufacturing and deployment of extremely hard and low-friction carbon coatings has long been an especially important topic for you and your colleagues. What are the reasons for this great interest?

Prof. Leson: Friction reduction is directly linked to reducing CO₂ emissions and improving energy efficiency, which is of central interest to our society. Our IWS developed superhard carbon coatings offer a tremendous potential as they are extremely wear resistant and also drastically reduce friction. In addition we have developed our Laser-Arc technology, which is now sufficiently mature to be deployed in industrial manufacturing. This technology has nearly no competition with respect to productivity and stability. Jointly with our partners we are intensively working on additional system deployments to industrial sites to exploit the full potential of these coatings. A special focus is the automotive industry and their suppliers. New concepts for two-wheeled vehicles which is interesting to me personally, will be explored.

Editor: In addition to all the work on friction reduction, are there other approaches that your department pursues?

Prof. Leson: Certainly. We have just finished, for example, a project that had the opposite goal, namely, to markedly increase the friction. This is in particular important for frictionally engaged force transmission or mechanical component connections. We demonstrated suitable PVD coatings which sharply increase friction. There are many applications that benefit from such high friction surfaces since these transmit higher forces and moments, implying the possibility of reducing the amount of required materials. These applications are in our focus to further explore with our partners.



COMPETENCES

X-RAY AND EUV OPTICS

Individual and multilayer nanometer coatings for EUV and X-ray optics are deposited using magnetron and ion beam sputter deposition as well as pulsed laser deposition techniques. The deposited coating systems meet the highest specification requirements with respect to film thickness accuracy, roughness, chemical purity, lateral homogeneity and reproducibility. Such coatings are used in X-ray optics and X-ray optical systems. In addition, we are developing reactive multilayers, which are applied in high-precision and reproducible joining processes. They are highly suitable for the joining of temperature-sensitive components. Apart from the development and fabrication of precision coatings we offer our long-term expertise in the field of characterization and modeling of nanometer coatings.

CARBON COATINGS

This group developed superhard ta-C carbon coatings (Diamor®), which are excellent protective coatings reducing friction in lubricated and non-lubricated application conditions. The coatings are deposited on various tools and components and with a wide range of possible thicknesses. The associated deposition process is the Laser-Arc technology, which was especially developed to produce ta-C coatings. Fraunhofer IWS engineers work on deploying Diamor® coatings in the market place. IWS and partners also offer the coating plasma sources and machines as well as the laser acoustic analysis technique LAwave® for quality control and coating optimization.

PVD COATINGS

Physical vapor deposition (PVD) techniques enable the deposition of high value added tribological and functional coatings covering a thickness range from a few nanometers to some hundreds of micrometers. The group has PVD processes at its disposal, e.g. high rate evaporation, highly activated plasma processes and their combinations. A special focus is the application of arc discharges, which most efficiently produce energetic vapor jets. Very thick PVD coatings are offered as well, which are suitable for many applications.



HEAD OF DEPARTMENT

PROF. ANDREAS LESON

phone +49 351 83391-3317

andreas.leson@iws.fraunhofer.de



GROUP LEADER

X-RAY AND EUV OPTICS

DR. STEFAN BRAUN

phone +49 351 83391-3432

stefan.braun@iws.fraunhofer.de



2014 PROJECT EXAMPLES

- | | |
|--|-----|
| 1. Corrosion protection for metallic bipolar plates | 92 |
| 2. Reducing sliding friction with Diamor® and lubricant | 94 |
| 3. Energy efficient window glazing through cost-effective retrofitting | 96 |
| 4. PVD coatings to optimize frictional power transmission | 98 |
| 5. Ion beam processing for highest precision optics | 100 |
| 6. Reactive multilayer systems for joining applications | 102 |
| 5. Nano in focus – multilayer Laue lenses focus X-rays | 104 |

GROUP LEADER

CARBON COATINGS

DR. VOLKER WEIHNACHT

phone +49 351 83391-3247

volker.weihnacht@iws.fraunhofer.de



GROUP LEADER

PVD COATINGS

DR. OTMAR ZIMMER

phone +49 351 83391-3257

otmar.zimmer@iws.fraunhofer.de



CORROSION PROTECTION FOR METALLIC BIPOLAR PLATES

THE TASK

Our society places a high value on individual mobility. Satisfying this demand in the face of limited resources requires new and sustainable mobility concepts. Therefore the Fraunhofer IWS is engaged in several research activities involving battery (pages 40/41 and 110/111) and fuel cell powered vehicles.

A fuel cell converts oxygen and hydrogen to water. This process yields a usable voltage of about 1 V per cell. Since this voltage is insufficient for automotive applications, these cells are combined to stacks containing up to 400 individual cells in series. The so-called bipolar plates limit the performance that a fuel cell stack can achieve. These plates have fine channel structures to deliver the gases and to remove water and electrical current as reaction products (Fig. 1). Simultaneously the bipolar plates cool the stack.

So far graphite has been the material for making bipolar plates. Graphite is a good electrical conductor and it is also resistant to the electrolyte, which is sulfuric acid. Since graphite is mechanically not very stable the plates are relatively thick. However, space is tight in vehicles. Therefore most automotive manufacturers produce the bipolar plates from thin formable foils made from corrosion and acid resistant steels. Stainless steel has a chromium oxide passivation layer, which protects it from corrosion but chromium oxide is a poor electrical conductor. This reduces the efficiency of steel foil bipolar plates.

OUR SOLUTION

The solution is to coat the stainless steel foils with a graphite-like film. This approach maintains the excellent properties of the stainless steel substrate in terms of formability, mechanical stability and low thickness and adds the high electrical conductivity and corrosion resisting properties of graphite.

The stainless steel foils are exposed to a vacuum plasma process to diffuse nitrogen and carbon into the surface layers (plasma nitro carburizing, PNC).

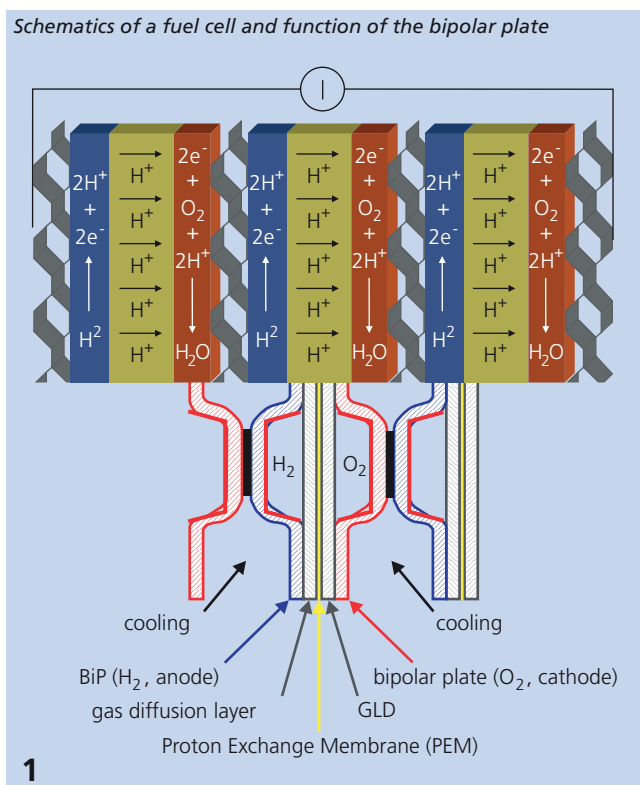

2



4



Fraunhofer IWS engineers have also developed and patented a hydrogen-free amorphous diamond-like carbon (DLC) coating, which has been successfully deployed in many applications (pages 94/95 and 98/99). The knowhow to correlate coating properties with processing conditions is used to engineer this material for more graphite-like behavior, i.e., to increase the amount of graphitic atomic bonding and to reduce the diamond character of the film. Such films are referred to as graphite-like carbon (GLC) and are electrically very conductive.

RESULTS

Both surface modifications immediately reduce the contact resistance by several orders of magnitude compared to untreated stainless steel, which makes it comparable to gold plated bipolar plates (see Fig. 3).

Contact resistance versus contact pressure for untreated stainless steel and several surface modifications

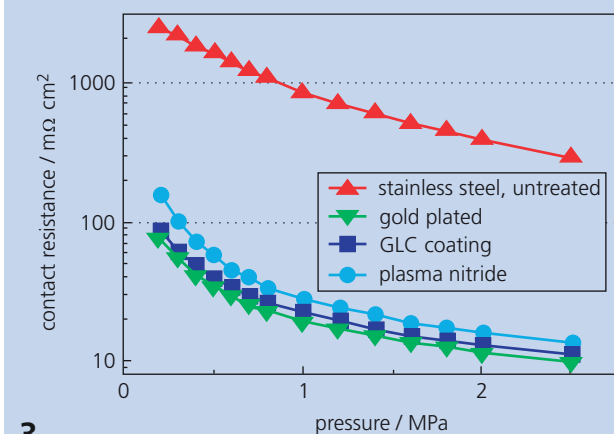

3

Potentiodynamic measurements in diluted sulfuric acid show five to ten times reductions of the passive current for PNC and GLC treated samples compared to stainless steel. Fuel cell stack endurance tests with treated bipolar plates proved sufficient long-term stability. Coated sheets can be formed into bipolar plate halves without delamination of the coating. The plate halves can then be joined to bipolar plates without difficulty.

The project was funded by the BMBF (MiniBiB project number: 0ET045A). The results show great potential to implement the developed solution into continuous industrial process. Treating the stainless steel material in an inline band process with subsequent forming and joining steps will be especially important to handle the required quantities.

2 *Stainless steel bipolar plate (demonstrator)*

4 *Bipolar plate consisting of two plate halves that were GLC coated, formed, laser cut and laser welded (demonstrator)*

CONTACT

Dr. Thomas Stucky
 phone: +49 231 844-3888
 thomas.stucky@iws.fraunhofer.de





REDUCING SLIDING FRICTION WITH DIAMOR® AND LUBRICANT

THE TASK

New materials and technologies help to address challenges such as resource shortages and climate change. An important goal is to improve efficiencies of machines, systems and vehicles. The consumption of resources needs to be reduced during manufacturing and operation of these products. Such goals imply the need to reduce weight, energy and fuel consumption.

Inevitable friction is a key factor during manufacturing as well as using mechanical systems. Mostly friction converts mechanical energy to undesirable heat. For years efforts have been made to reduce friction. Technical accomplishments include the development of high performance engine oils and precision ball bearings. In internal combustion engines, for example, the friction between metal surfaces in sliding contact is reduced by oil lubrication. The savings potential of this approach, however, is mostly exploited. Improvements can only be expected from new approaches.

OUR SOLUTION

Fraunhofer IWS Diamor® coatings are superhard hydrogen-free amorphous carbon coatings that are also referred to as ta-C coatings. Their extraordinary properties exceed those of traditional hydrogen containing carbon coatings in many areas. Diamor® coatings further reduce the friction in oil lubricated systems. Wear is minimized due to Diamor®'s extraordinary hardness.

The coating material is also chemically inert, which translates to outstanding emergency and dry run performance in direct contact with steel surfaces. An especially exceptional potential for further friction reduction is expected from the in recent years researched effect of **superlubricity**, which occurs when ta-C is combined with specific lubricants. In these optimized circumstances the resulting coefficient of friction can be lower than 0.01. For many applications this effect provides a friction reduction of about 90 %. Under such conditions expensive ball bearings can be replaced by much cheaper coated plain bearings.

Besides known model lubricants, systematic research found additional environmentally harmless materials. The project was funded by the BMWi (PEGASUS project number: 0327499B). The starting point of the investigations was a conventional steel/steel contact lubricated with motor oil. The influence of the Diamor® coating in combination with different lubricants was studied. The deposition and post-processing of the Diamor® coatings were performed with industrial processes at Fraunhofer IWS. These have recently been commercially deployed.



2

RESULTS

The economically preferable solution is to coat just one surface of a friction pair. This solution reduces friction by 20 % compared to the motor oil reference. The use of model lubricants as suggested in the literature further reduces friction. Systematic research with lubricants of similar chemical classes revealed that nearly all vegetable oils and their fatty acid-based modifications show the effect.

Fig. 3 shows that rapeseed oil reduced friction by 65 %. Using untreated vegetable oils is a very attractive option as it is environmentally favorable and cost-effective. Applications are possible in agriculture, forestry, food processing and low-tech machinery.

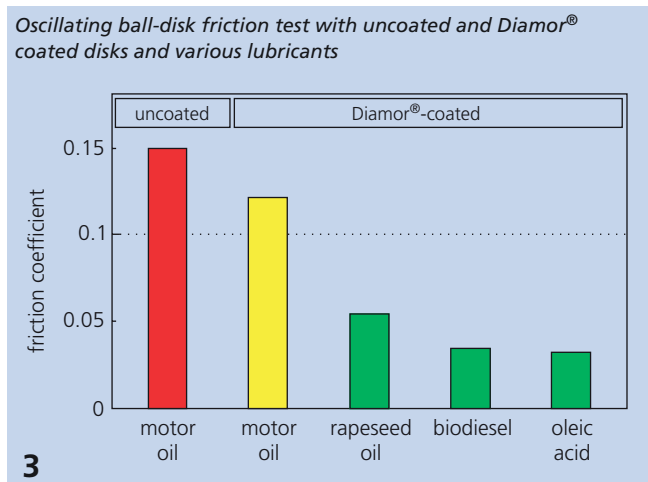

3

Biodiesel and fatty acids such as oleic acid even reduce friction by 80 %. Biodiesel is not only a common fuel for diesel vehicles, it also serves as the lubricant in high pressure diesel pumps for diesel vehicles, which makes coated components for more powerful pumps a possible application.

The strong influence of process temperature, surface condition, coating properties and the occurrence of so far unknown wear phenomena indicate that chemical reactions may be responsible for superlubricity. Mechanical models fail to predict this behavior.

Successful results were also achieved under application-near conditions. Diamor® coatings in combination with environmentally harmless lubricants based on renewable raw materials promise a new approach to reduce resource and energy consumption. Fraunhofer IWS scientists have developed the Laser-Arc technology, which is an industrial tool to manufacture ta-C coatings and, novel friction reduction solutions.

- 1 Model test stand to study sliding friction
- 2 Diamor® coated components of high pressure diesel pumps

CONTACT

Dipl.-Ing. Stefan Makowski
 phone: +49 351 83391-3192
 stefan.makowski@iws.fraunhofer.de





ENERGY EFFICIENT WINDOW GLAZING THROUGH COST-EFFECTIVE RETROFITTING

THE TASK

In the United States architectural glass windows account for 15 - 20 % of the building envelope areas. The US Department of Energy estimates the energy losses through windows to be approximately 50 - 60 %. This means that more than half of all heating and cooling energy gets lost through windows. This energy waste costs the nation approximately 50 billion dollars per year.

Currently the best commercial solution to reduce thermal energy losses through windows is to install multi pane windows with so-called "Low-E" coatings. Low-E or LE glass is coated with a thin and optically transparent film, which features low thermal emission properties in the infrared spectral region. Many applications of LE glass use very thin metal films such as silver. Disadvantages of this solution include the high weight of double or multi pane windows and the high costs of replacing them when they start to fail. This can happen when air penetrates in-between the panes and corrodes the Low-E coating.

Other approaches such as adhesive foils mounted directly to the glass pane are often not effective, hard to install, optically not attractive and in many cases expensive, so that installation costs cannot be recouped by energy savings within 10 years. The task is therefore to develop a simple retrofit solution for already existing windows, which provides substantial energy savings yet does not diminish the optical appearance of the window.

OUR SOLUTION

In collaboration with an industry partner, scientists at the Fraunhofer USA Center for Coatings and Laser Applications in East Lansing, Michigan, developed a cost effective and adaptable solution to make already existing windows substantially more energy efficient.

The concept is based on a very thin, lightweight, optically transparent and UV stable polymer film that is coated with a wavelength selective and nonmetallic Low-E coating. In the range of visible wavelengths the coated polymer film is completely transparent. This polymer film is not adhering to the glass surface. Instead the film is installed as an insert in a lightweight frame, which attaches to the existing window frame on the inside of the building. It can easily be configured, installed and removed (Fig. 1). This approach allows for retrofitting already existing window installations. The simplicity of the retrofit solution is also suitable for installing several Low-E films with one insert and thus connecting low emissivity functions in series to further reduce thermal transport (Fig. 2).

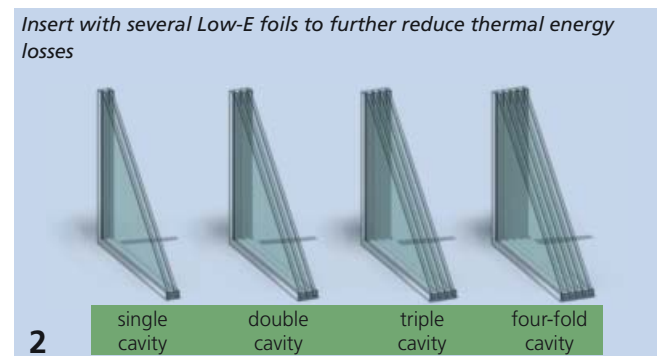

RESULTS

The proposed retrofit solution was selected as a winning idea in a competition addressing the energy efficiency of buildings. This competition was sponsored by US energy giant DTE Energy Company and the winning proposal was awarded funding to demonstrate feasibility and build prototypes. The industry partner used Fraunhofer CCL coated foils and mounted them in inserts, which were then performance tested under real world conditions by an independent third party research institution (Calvin College, Engineering Department in Grand Rapids, Michigan).

Fig. 4 (left) shows a photo of the test window with four main segments. Fig. 4 (right) shows infrared images. The photo was taken during winter months just prior to sunrise. The outside temperature was 24 °F (-4.4 °C) and the inside temperature was 68.5 °F (20.3 °C). The heat loss is highest in the upper right segment, which is equipped with just a single glass pane. Much less heat gets lost through the upper left segment. This segment has in addition to the single glass pane a one-foil Low-E coated polymer insert installed. The lower segments are retrofitted with 2 (left) and 3 Low-E polymer foil inserts, which further reduce the energy loss.

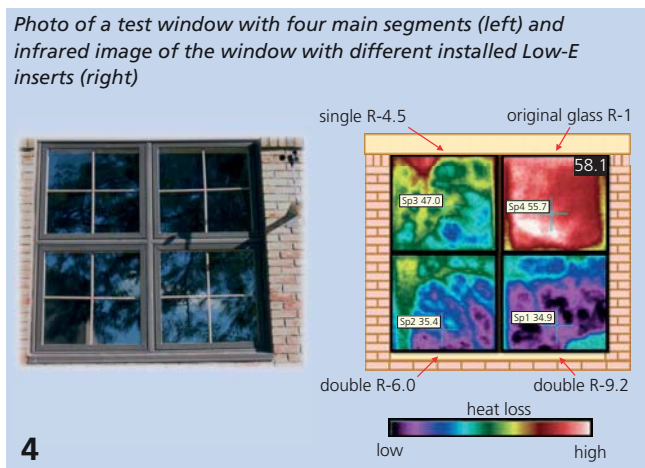

The R-values in Fig. 4 represent the thermal resistance and are typically used in US units of BTU/(h °F ft²). These can be converted to SI units of W/(m² K) by dividing the numerical values by 5.7. The thermal resistance is a typically measure in the construction industry and represents the reciprocal value of the heat transfer coefficient. Higher R-values mean better insulation. The US Department of Energy aims for R-values of 10 for windows to achieve energy neutrality with minimal heating and cooling losses while simultaneously maintaining sufficient daylight transmission. This R-value was almost achieved by the triple Low-E insert with Fraunhofer coating (Fig. 4, lower right window segment R = 9.2). For comparison Tab. 1 compiles a list of R-values for various solutions.

R-values in BTU/(h °F ft²) for typical window glazing (<http://www.coloradoenergy.org>)

window type	R-value in BTU/(h °F ft ²)
single pane glass	0.91
double pane glass, 3/16" spacing	1.61
double pane glass, 1/2" spacing	2.04
double pane glass, 1/2" spacing with single Low-E coating	3.13
triple pane glass, 1/2" spacing	3.23
Fraunhofer single pane glass with single Low-E insert	4.5
Fraunhofer single pane glass with triple Low-E insert	9.1

- 1 Single Low-E insert retrofit installation of the Low-E polymer film in front of the actual window

CONTACT

Dipl.-Ing. Lars Haubold
phone: +01 517432 8179
lhaubold@fraunhofer.org





PVD COATINGS TO OPTIMIZE FRICTIONAL POWER TRANSMISSION

THE TASK

Frictionally engaged component connections such as clamp, flange or screw connections are present in nearly all technical applications including mobile powertrains, steel constructions and wind energy systems. Such connections can transmit more power and higher torques if the static friction between the connecting surfaces is increased or if more connection elements (e.g. screws) are installed. Alternatively, higher static friction would be beneficial to maintain power transmission with reduced dimensions of connection elements and thus improved volume efficiencies.

There were approaches to increase static friction in the past. One solution was to attach hard particles to foils and place these between the engaging surfaces. Another solution is based on thermal spray coatings with a metal matrix and embedded ceramic particles, which were deposited on one of the engaging surfaces. In both cases the thickness (in the range of 1/10 of a millimeter) of either the foil or the thermal spray coating has to be considered during the design phase of the component. Thin film hard coatings for tools and components are deposited using PVD processes. These coatings are known for their wear resistance and tendency to not adhere to the counterpart. There are no known solutions to purposely increase the friction of these coatings. However, if this were possible it would offer a space saving solution to reliably increase static friction in diverse environments.

OUR SOLUTION

Arc-PVD process is an industrial standard process to coat tools. A specialty of this process is the emission of microscopic droplets in addition to the coating plasma. These droplets are incorporated into the coating.

By means of a suitable coating design, IWS engineers were able to use of the droplet-induced roughness to create surfaces with very high static friction. Combined with the high wear resistance and good adhesion to the substrate this system offers an excellent solution to create reliable and long-term stable static friction performance for a given friction couple.

RESULTS

Initial experiments indicate two possible coating systems, which could be suitable to increase the friction coefficient:

- hard amorphous carbon coatings (ta-C)
- Nimonic90- AlTiN

Arc deposition of such coating systems results in pronounced micro roughness. In case of the carbon coating this is the result of hard carbon particles, which form during the evaporation of graphite and incorporate structurally into the coating surface (Fig. 2). The Nimonic90- AlTiN system is built from a Nimonic layer with marked roughness (Fig. 4), which is then coated with a thin AlTiN film to stabilize the surface structure.

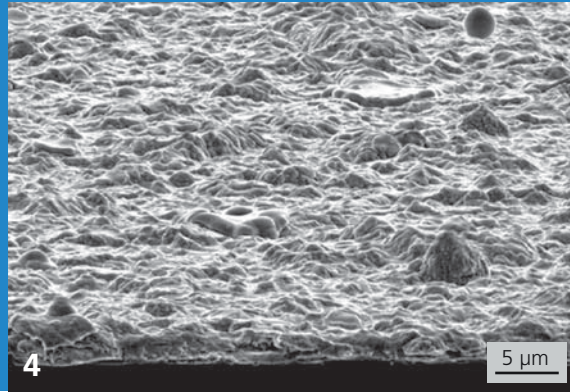
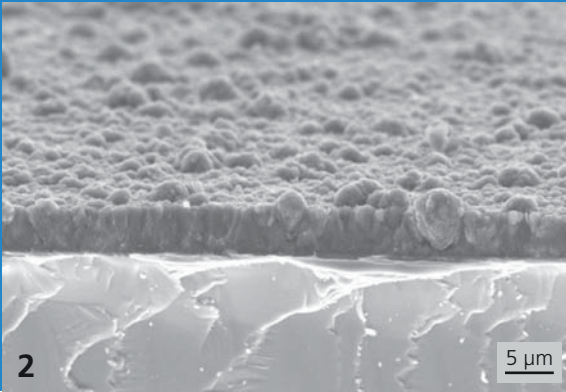

The friction behavior was evaluated in a torsion test stand. The friction couple is pressed together at various pressures and then twisted. The torsional moment is measured as a function of the twist angle. Various friction parameters are derived from the data such as $\mu_{0.1}$ (coefficient of friction at 0.1° torsion) μ_{max} (maximum coefficient of friction).

The torsion tests require special test specimen. One side of each friction couple was coated. The film thickness was for both coatings between 3 and 5 microns. The counter surface remained uncoated.

The measured friction coefficients are shown in Fig. 3. Both coatings achieve values between 0.5 and 0.8 (depending on experimental conditions). These data represent a substantial increase compared to mechanically processed steel surfaces (friction coefficient of about 0.2).

Additional experiments were performed to study the influence of different environments such as lubricating of the friction surfaces. The results showed only a slight reduction of the friction coefficients of about 10 - 20 %.

Coated surfaces therefore offer a high potential to reduce material and space when optimizing frictionally engaged joints. PVD coatings are especially suitable. The low thickness of the coatings makes it possible to integrate them into mechanical systems without problems.

This project was funded by the German Federation of Industrial Research Associations (AiF), project number: 17230 BR/1. We thank the Institute for Construction and Drive Technology at the TU Chemnitz for performing the torsion tests.

Friction coefficients $\mu_{0.1}$ and μ_{max} of coated friction couples at pressures of 30 MPa, 100 MPa and 300 MPa.

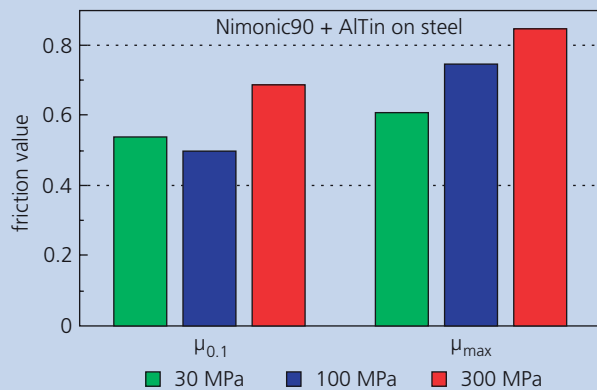
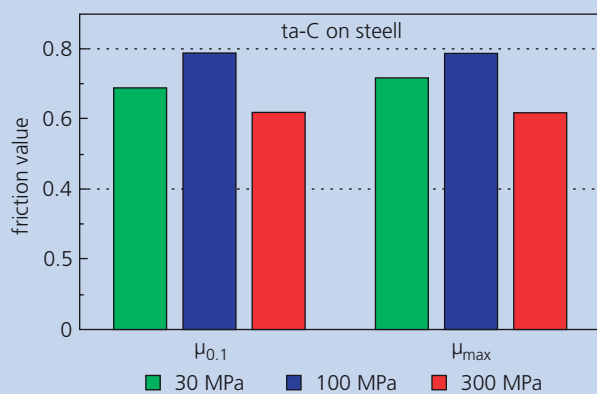

- 1 Flange and shrink fit connections
- 2/4 Fracture image of arc deposited ta-C (2) and metal (3) coatings for friction increase

CONTACT

Dr. Otmar Zimmer
 phone: +49 351 83391-3257
 otmar.zimmer@iws.fraunhofer.de



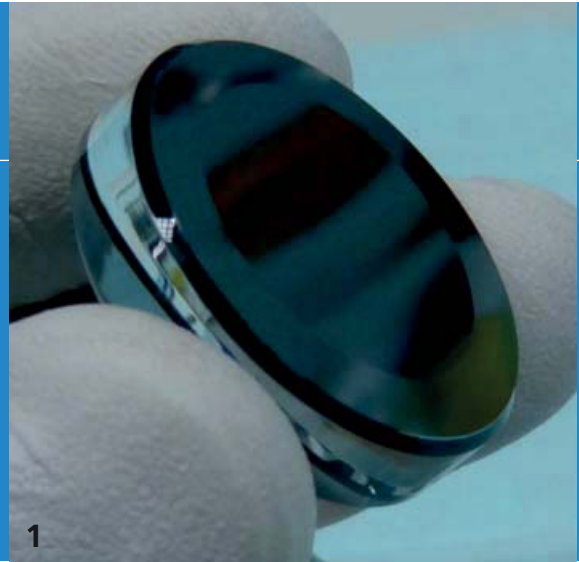

ION BEAM PROCESSING FOR HIGHEST PRECISION OPTICS

THE TASK

The manufacturing of optical mirrors for EUV (extreme ultraviolet) and X-ray radiation requires highest precision and quality of the processes for shaping, smoothing and coating the mirrors. Important parameters include the optical properties of the coating materials and the perfection of the multilayer reflective coating stack. It is also important that the mirror substrate precisely follows the desired contour and that the surface roughness is minimal.

The multilayer coating is primarily responsible for the spectral reflection behavior of the mirror. The beam shape or the caustic of the reflected light is defined by the contour of the mirror. Strongly curved 2D surfaces are required to focus the beam at short focal lengths or high aperture angles. Synchrotron optics, on the other hand, require flat and relatively long substrates with smallest tilt tolerances.

However, the biggest challenge for all shaping processes is the required surface smoothness of a few 0.1 nm, which is a basic condition to achieve sufficient reflectivity at these wavelengths.

OUR SOLUTION

Ion beam bombardment in vacuum is a suitable method to reproducibly remove layers and create profiles in typical mirror materials such as silicon and special glasses. The ballistic ion surface interactions also initiate surface processes on an atomistic scale, which ultimately achieves the targeted

smoothness. The substrates are typically mechanically or wet chemically polished prior to the ion beam treatment. The ion beam process then creates aspherical profiles and/or further smoothens the surface. It is important to minimize slope errors, which requires very homogenous material removal processes.

The Fraunhofer IWS has a UHV ion beam sputter unit. The system handles all processing steps to fabricate EUV and X-ray optical components, which include shaping, smoothing and cleaning of the initial substrates as well as the deposition of multilayer coatings with nanometer precision. Each process step requires specific ion energies and current densities. Two ECR ion sources are installed with adjustable ion energies from 50 to 2000 eV. An aperture system is used to mask the material removal and shape the deposition profiles. Optical substrate areas up to 500 x 200 mm² can be homogeneously and reproducibly processed.

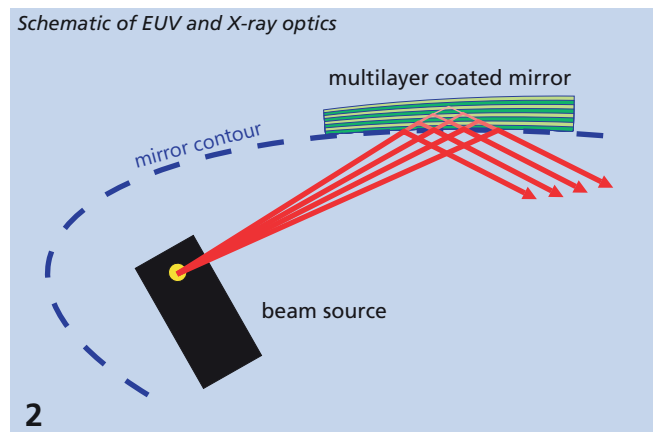



RESULTS

Ion beam milling was used to smoothen a flat optical component for synchrotron applications. The part had an initial microroughness of $R_q = 0.57 \text{ nm}$. The meridional residual curvature radius of the as-delivered optics was 15.5 km (concave). This corresponds to a deflection in the middle of the part of about 270 nm . The slope error was about $0.25 \text{ } \mu\text{rad rms}$ (0.06 arcsec). After removing 500 nm of silicon the process reduced the microroughness to $R_q = 0.28 \text{ nm}$ (Fig. 4).

Fig. 5 (top plot) shows that the surface was homogeneously reproduced. The relative error of the material removal depth is about $\pm 0.4 \% = 2.4 \text{ nm}$. The slope error (Fig. 5 bottom plot) remains nearly unchanged across this region at $0.28 \text{ } \mu\text{rad rms}$. The deviations near the supporting edges of the substrate can be attributed to the fact that these areas were not treated. When using mirror fixtures without supporting edges the entire surface can be processed as ok as the center area in this example .

AFM images of the surface of a single crystalline silicon synchrotron mirror
 Top: untreated substrates, microroughness $R_q = 0.57 \text{ nm}$
 Bottom: about 500 nm material removal due to ion beam smoothing, microroughness $R_q = 0.28 \text{ nm}$.

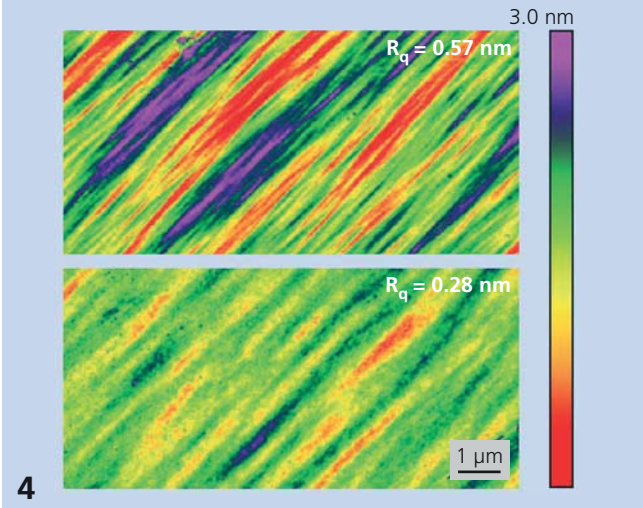

Substrate contour (top) and slope error (bottom) of a synchrotron optical component in meridional direction prior to and after ion beam processing (Measurements: F. Siewert, NOM / HZB Berlin)

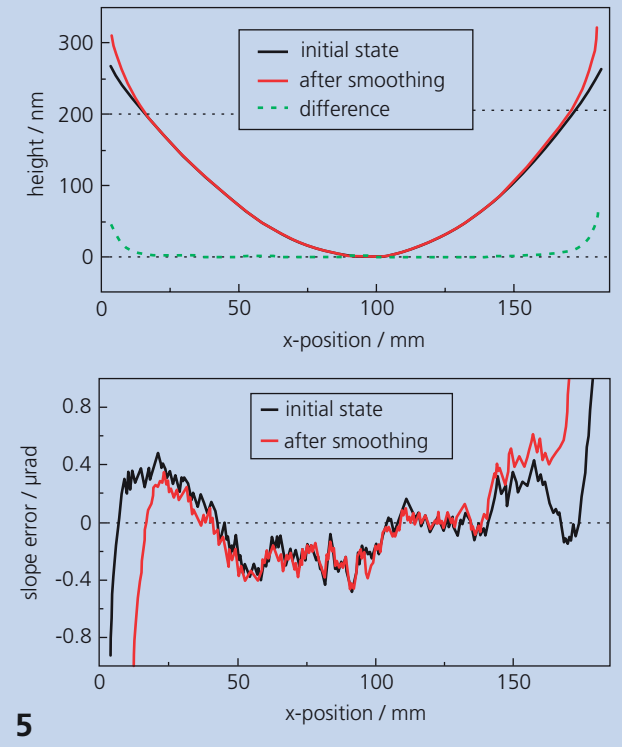

Parts of the presented work were founded by the European Union (EFRE) and the Free State of Saxony (SAB, contract no. 990.301018.5)

1/3 Example photos of EUV and X-ray optics

CONTACT

Dipl.-Phys. Peter Gawlitza
 phone: +49 351 83391-3431
 peter.gawlitza@iws.fraunhofer.de





REACTIVE MULTILAYER SYSTEMS FOR JOINING APPLICATIONS

THE TASK

In recent years Fraunhofer IWS engineers have developed so-called reactive multilayer systems (RMS) based on Ni/Al. These coating systems serve as in-situ heat sources for joining processes in temperature ranges compatible with thermoplastics as well as tin-based soft solder joints. RMS find applications in micro systems technology for joining materials with extremely different coefficients of thermal expansion and for joining thermoplastics.

RMS need to be further developed to make this joining technology accessible to other applications. Current research focuses on the use of higher melting point solders and on joining thermoplastic composite materials.

OUR SOLUTION

A multilayer RMS is placed right at the joining zone to serve as an internal heat source for melting the materials or solders. This approach has many advantages. The heat delivery is much localized and occurs over a short period of time. The bonding parts remain at room temperature and only the immediate joining zone heats sufficiently to enable the process. The RMS can be designed for the specific joining task. The multilayer design can be adjusted, which controls the amount of heat that will be released during the reaction (Fig. 2). To achieve higher reaction temperatures, as they are required for hard solders, the amount of heat released during the RMS reaction has to be increased. This is possible by using an RMS stack with a greater overall thickness. If it is impossible to increase the thickness due to design or technical constraints material systems with higher energy densities such as Zr/Si can be used.

Thermoplastics and thermoplastic composite materials can be firmly bonded using the RMS technology. Material systems with lower energy densities such as Ni/Al are used to avoid damage to the thermoplastic matrix.

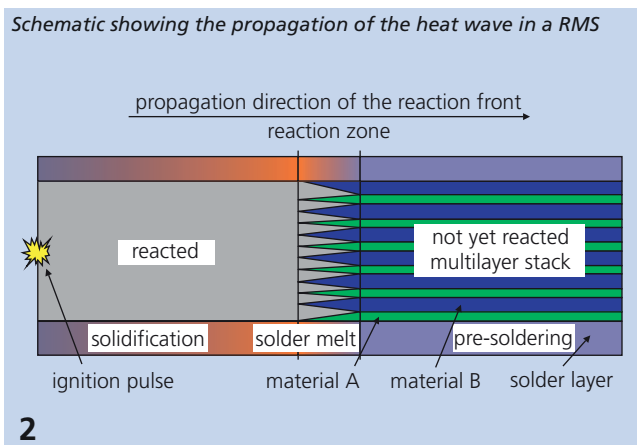

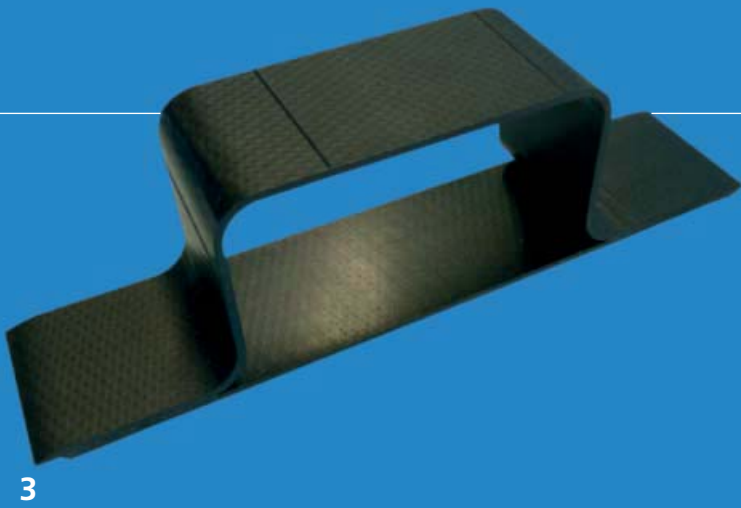

RESULTS

So far this reactive technology has primarily been used for joining applications based on soft solders. Melting hard solders requires temperatures of up to 720 °C, which requires more heat to be released from the RMS. Fraunhofer IWS engineers are using Ni/Al RMS with thicknesses of up to 120 µm. Another approach to increase the released amount of heat is to use novel and highly energetic RMS based on Zr/Si. These deliver up to twice the heat compared to Ni/Al RMS and are especially suitable for hard solder joining applications.

Silver-based hard solders and/or solders based on the eutectic aluminum alloy AlSi₁₀ were pre-soldered onto the RMS to join copper, aluminum and steel materials (Fig. 1). Already the first experiments were very successful. The joint strengths ranged from 20 - 40 MPa. An important point is that RMS joining can be done with AlSi₁₀ solder without the need for soldering flux, vacuum or inert gas conditions. After the solder is pre-soldered onto the RMS these can be laser cut to specific shapes tailored to the joining application (Fig. 4). The cut shapes solder exactly at the desired location since they provide both the solder and the heat for the soldering process.

Laser structured RMS preform frame for casing construction



The RMS technology was also further developed for applications with fiber reinforced thermoplastic composite materials. Usually these materials are adhesively bonded, which requires pretreatment and long curing times. Adhesives also suffer

from aging. The IWS developed reactive joining technology offers a clear alternative. Almost no pretreatment is required. The joining process is completed in a very short time and ensures a long-term stable bond.

Shear tension tests were performed with RMS bonded sections of non-reinforced polyamide. Once the critical loads passed the material's strength, the polyamide failed in the base material and not in the region where the sections were bonded. It was also demonstrated that the thermoplastic matrix of CFC and GFC materials could be used to firmly bond material sections among themselves and with thermoplastics using RMS technology (Fig. 3). Furthermore, first experiments proved the feasibility of joining thermoplastics with aluminum and steel materials.

Some of the results were developed in a collaborative project "Reactive joining in micro systems technology" (REMTEC, IGF: 17.370 B).

- 1 *Reactively joined material combinations*
- 3 *Reactively joined hat profile made of carbon fiber reinforced polyetherimide*

CONTACT

Dipl.-Ing. Georg Dietrich
phone: +49 351 83391-3287
georg.dietrich@iws.fraunhofer.de





NANO IN FOCUS – MULTILAYER LAUE LENSES FOCUS X-RAYS

THE TASK

X-ray microscopy is a promising technique for various applications to non-destructively study smallest structures. Conventional light microscopy is limited to a resolution of 200 nm. X-ray microscopy on the other hand offers potentially much higher resolutions. Improvements over the current state-of-the-art are especially anticipated from further developing optical X-ray components. Multilayer Laue lenses (MLL) are one of the most promising developments. They could yield resolutions in the nanometer range.

MLL are zone plate structures, which are fabricated using thin film technology. Fraunhofer IWS engineers have previously demonstrated coatings for MLL achieving a beam focus of less than 50 nm with diffraction efficiencies of 11 %. In order to further improve the beam focus and the diffraction efficiency of the lens it is necessary to develop a better understanding of the diffraction properties inside the lens.

OUR SOLUTION

Fraunhofer IWS scientists developed a method to calculate the behavior of X-rays within the lens. This method is used to simulate the imaging and focusing performance as a function of the lens properties. Consequently one can determine optimal lens properties and permissible fabrication

tolerances for each application. An example calculation of the focusing performance was performed for the following MLL design:

- X-ray energy: 10.5 keV
- focal length: 1 mm
- zones: 100 - 500
- total thickness: 4.3 μm
- material WSi_2/Si

The WSi_2/Si material combination was selected as it corresponded to the used experimental lenses. The calculations were performed to compare the effect of various lens geometries. The simulations predicted effects, which were also seen with real lenses.

MLL can be used in different geometries. The three most important designs are shown in Fig. 1. The first variant is equal to the zone plate design where all zone boundaries are aligned parallel to the optical axis (flat geometry, Fig. 1a).

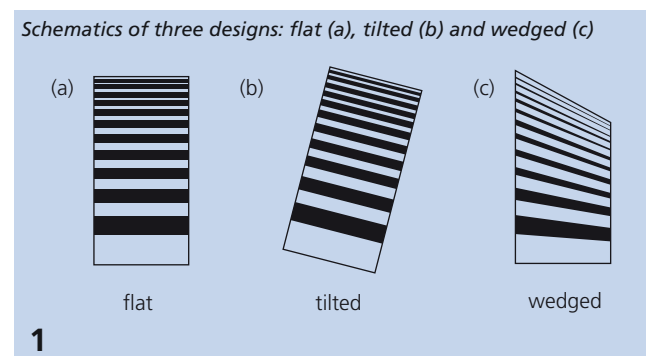

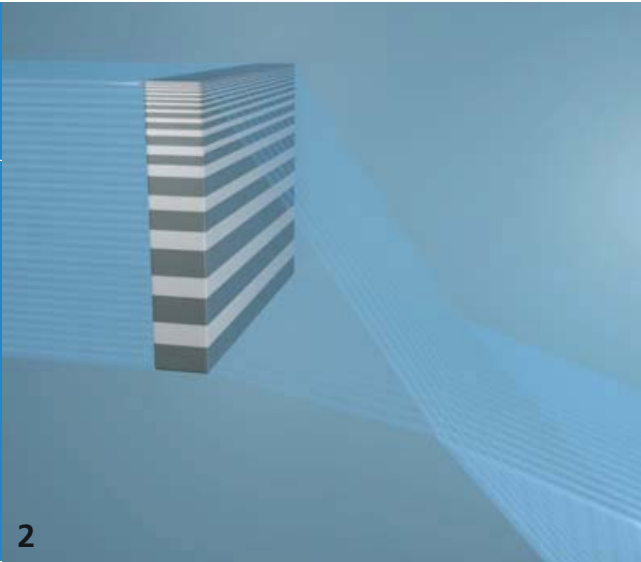

2

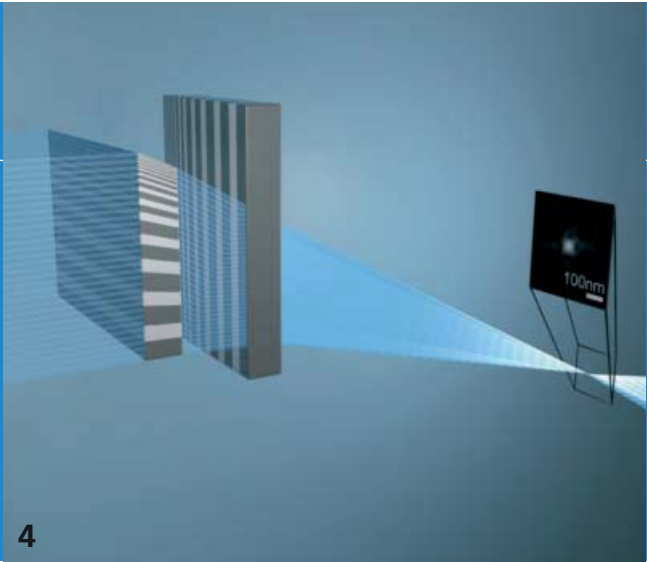

4

The lens can be tilted so that a part of the zones matches the Bragg conditions. This design achieves much better diffraction efficiencies (tilted geometry, Fig. 1b). Even higher diffraction efficiencies can be reached by aligning all zones to meet their respective Bragg conditions (wedged geometry, Fig. 1c).

RESULTS

The simulations use a model that assumes the interaction of plane waves with the various lens designs at optimum structure thicknesses. The result of the calculation is the beam profile in the focus, i.e., the beam intensity as function of the position perpendicular to the optical axis. A well focusing optics will yield a pronounced maximum with a small halfwidth.

The example clearly shows the need to develop wedged lens designs to achieve smaller beam sizes and higher intensities in the beam focus.

Focusing experiments using tilted and wedged lenses were performed at the beam line ID13 at the European Synchrotron Radiation Facility (ESRF) in Grenoble, France. For the first time ever the scientists tested a pair of crossed and wedge shaped lenses. The experimental and lens parameters were as follows: (X-ray energy: 10.5 keV, focal length: 6.6 mm, zones: 850 - 7850, total thickness: 53 μm , material WSi_2/Si).

An aperture of 15 μm was used for the focusing experiments. The focus size was lower than 45 nm in both directions. The efficiency was 20 % and thus has clearly improved over tilted lenses and approaches the theoretical limit.

Some of the presented works were performed with European Union (ERDF) and Free State of Saxony grant funding (project ENano 1000 87859). The Fraunhofer IWS thanks the Fraunhofer IKTS-MD and the Chair for Structural Physics of Condensed Matter at the Technische Universität Dresden.

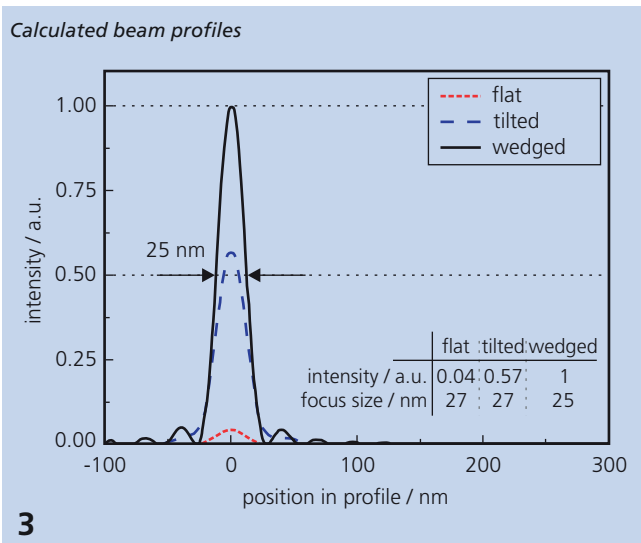

3

2 *Focusing through a multilayer Laue lens*

4 *Experimental results: Intensity of the focus for a pair of crossed wedged multilayer Laue lenses*

CONTACT

Dipl.-Phys. Adam Kubec
 phone: +49 351 83391-3572
 adam.kubec@iws.fraunhofer.de



HEAD OF DEPARTMENT
PROF. DR. STEFAN KASKEL



"Insight must precede application."

Max Planck



BUSINESS UNIT CHEMICAL SURFACE AND REACTION TECHNOLOGY

Editor: Prof. Kaskel, why are you working so intensively on sulfur batteries?

Prof. Kaskel: Electrode materials containing cobalt and lithium contribute up to 40 % of the costs of the cell materials. This fact implies a substantial demand for alternative and less expensive electrode materials. Sulfur is a waste product of the chemical industry, which accumulates in huge quantities in the Middle East. This makes sodium- and lithium-sulfur batteries extremely inexpensive. Additionally the theoretical capacity of sulfur is 1600 mAh/g and thus substantially higher than the capacity of established cathode materials such as NMC.

In the mid-term it can be expected that lithium-sulfur batteries will double the energy densities currently typical. However, there remain substantial challenges to be solved. This is in particular the low cycle stability of the lithium-sulfur battery. Today commercial products achieve only 50 cycles, however, in recent years our development of alternative anode materials has led to the realization of 4000 cycles. This is certainly a milestone in the area of sulfur batteries.

Editor: Prof. Kaskel, which applications do you see?

Prof. Kaskel: One use is of course in electro mobility applications, which is not limited to electro vehicles and cars but is also relevant to small crafts and electrically powered bicycles. This is certainly a future market. There are also ever new requirements for stationary energy storage devices to manage Germany's energy transition and to buffer electricity peaks, which occur due to the use of regenerative energy sources. In that sense we are expecting a positive development of the battery market in the coming years.

Editor: Will these developments demand more from current production methods?

Prof. Kaskel: Absolutely. The development of novel production methods is essential to reducing the costs of new battery systems. Process monitoring, meaning the efficient control of production flows in particular with optical techniques is critical for further developments. In recent years we have developed entirely new technologies such as the so-called hyperspectral imaging for extensive film analytics. This method is used to perform large area chemical analyses with spatial resolution.

Equally important are new production methods such as laser cutting of electrodes and joining processes, which connect copper and aluminum arrestors with low contact resistances. The parallel development of new materials, fabrication processes and systems technology is key to developing new battery systems.



COMPETENCES

CHEMICAL SURFACE TECHNOLOGY

Our scientists focus their research on gas and liquid gas phase processes for large area coating tasks. Apart from functional thin films with conductive, scratch resistant or self-cleaning properties we concentrate our research work on the field of electrode coatings for energy storage devices. Water-based coating technologies in a roll-to-roll procedure and solvent-free processes are being developed to advance a more cost-efficient fabrication of double-layer capacitors and batteries. Focus here is the lithium-sulfur battery as a highly capacitive storage system of the next generation.

PLASMA AND REACTION TECHNOLOGY

The group develops and modifies large-area, atmospheric pressure plasma sources for customized procedures. Diverse areas of applications are opened up for procedures such as adhesive bonding preparations, coating of adhesion promoting layers as well as powder deposition via plasma technologies. Another focus is the development of gas phase reactors for the fabrication of nanoparticles and metallically conductive nanotubes (CNTs). In particular, we developed flexible, cost-efficient high-rate synthesis procedures for the fabrication of single-walled, low-defect CNTs.

PROCESS MONITORING

Opto-spectroscopic techniques provide a superb tool for monitoring industrial production processes. Products can be characterized during or after fabrication. Various methods provide information about process atmospheres (gas composition) and product properties (surface, coatings, composition, porosity etc.). This data is obtained contact-free, with high sensitivity and sometimes even with lateral resolution. The results are exploited for automated monitoring, controlling and the optimization of such processes.



HEAD OF DEPARTMENT

PROF. STEFAN KASKEL

phone +49 351 83391-3331

stefan.kaskel@iws.fraunhofer.de



**GROUP LEADER
CHEMICAL SURFACE TECHNOLOGY**

DR. HOLGER ALTHUES

phone +49 351 83391-3476

holger.althues@iws.fraunhofer.de



**GROUP LEADER PLASMA
AND REACTION TECHNOLOGY**

DR. GERRIT MÄDER

phone +49 351 83391-3262

gerrit.maeder@iws.fraunhofer.de



**GROUP LEADER
PROCESS MONITORING**

DR. WULF GRÄHLERT

phone +49 351 83391-3406

wulf.graehlert@iws.fraunhofer.de



2014 PROJECT EXAMPLES

- | | |
|--|-----|
| 1. Cell concepts for lithium and sodium based secondary batteries | 110 |
| 2. Innovative coatings for room temperature sodium sulfur batteries | 112 |
| 3. Roll-to-roll process for transparent electrically conductive surfaces | 114 |
| 4. Recycling of process gases with porous materials | 116 |
| 5. Plasma bonding of polymer foils at atmospheric pressure | 118 |
| 6. Automated material identification by spectral image analysis | 120 |

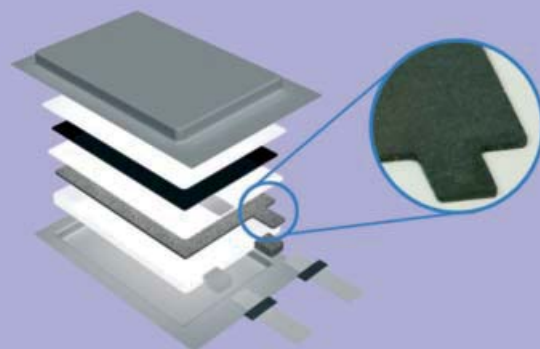
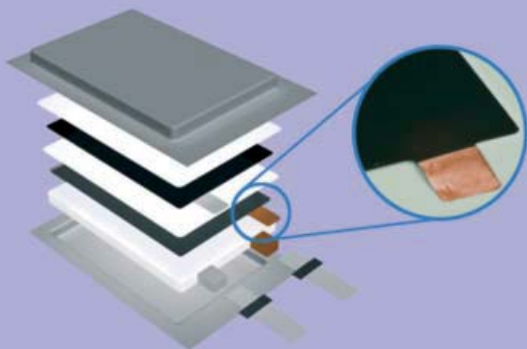

1

CELL CONCEPTS FOR LITHIUM AND SODIUM BASED SECONDARY BATTERIES

THE TASK

Increasing electrical storage capacity is an important development goal in battery research. Work focuses on improving the active storage components. Milestones are to increase the energy density and to get high charging and discharging rates. High cycle stabilities and the design of intrinsically safe cell systems are crucial.

Today batteries are primarily available in the form of wound cylindrical cells. Larger capacities are available in form of prismatic cells, which consist of a wound or stacked electrode package. Mobile devices for example have specifically designed wound prismatic cells.

In particular for mobile applications the desire is to store the electrical energy in a form factor as compact as possible. Another important consideration is the cell weight as well as the weight of the packaging. Stationary applications (e.g., local storage of solar energy) are less sensitive to weight and space constraints.

Future energy storage systems have to meet a wide variety of requirements. Depending on the cell chemistry this also requires new cell concepts.

OUR SOLUTION

An innovative approach for future cell concepts is to fundamentally change the electrode design. Fraunhofer IWS researchers are therefore exploring how metal foam structures can be used to host the active material and to improve the cell performance over current collector foils made from copper or aluminum, which are coated with active material (Fig.1). Fraunhofer researchers collaborate with universities and other Saxon research institutions in two projects (BamoSa, BMBF, project number: 03X4637A-H and BaSta, BMWi project number: 0325563A) to evaluate this concept for the two different cell materials lithium-sulfur and sodium-sulfur at room temperature.

The new electrode concept is based on metal foam current collectors with infiltrated active material. Their fabrication poses new challenges. Laser remote cutting processes shape the electrodes. Preferable the cutting process is performed prior to loading the electrodes with active material to minimize damage to the surface regions.

Contacting the electrodes with each other and conducting the current from the cell is performed as follows:

- a) Pressing the foam electrodes whereby the current collector is placed in-between the electrodes and thus mechanically anchored.
- b) Laser welding of the electrodes and the current collector to increase mechanical stability and reduce contact resistance.



RESULTS

Battery cells based on this electrode design can be used in prismatic hard case cells and in cylindrical cells (Fig. 2). The fabrication steps were developed, tested and optimized for manufacturing cylindrical cells for stationary room temperature sodium-sulfur batteries.

Contacted foam electrode and assembly in cylindrical stack cell

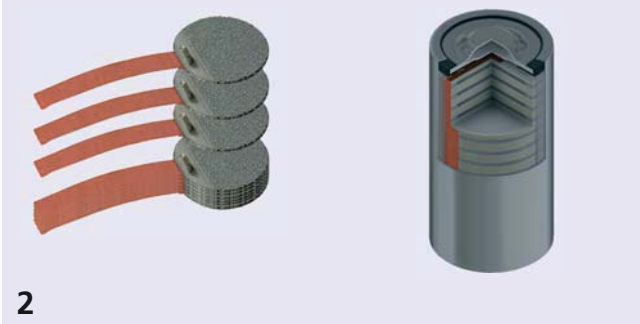

2

When stacking anode and cathode foam elements one has to ensure that the individual electrodes are connected to each other. On the other hand, the two types of electrodes must not be electrically shorted via the metallic case. While inserting the electrodes into the shell no conductive material must spread across the separator since this could also form an electrical short with the counter electrode.

Test cells were built using shrink tubes. These stabilize the electrodes along the side and provide electrical insulation from the case. The electrode contacts are remote laser welded to casing elements. The short interaction time with the laser minimizes the heat load for the electrodes while simultaneously providing a solid electrical connection of the cell stack.

Welding the electrode foams to metallic current collectors was successfully performed (pages 40/41).

Electrodes based on metal foam structures have a very low internal resistance. Charging the metal foams with active material can be tailored to desired cell properties and customer specifications.

The long-term performance and aging behavior of the cells have to be evaluated. The interaction of cell chemistry (active material, electrolyte) with metal foams and possible materials for the current collectors is very complex. Another ongoing research subject is the composition of the active material. The remaining project time will be used to further optimize the cell properties.

- 1 *Left: conventional electrode stack with Cu and Al current collector foils, Right: electrode stack with foam electrode instead of Cu anode*

CONTACT

Dr. Philipp Thümmeler
phone: +49 351 83391-3215
philipp.thuemmler@iws.fraunhofer.de



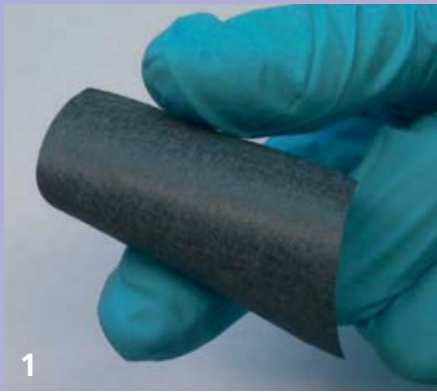

INNOVATIVE COATINGS FOR ROOM TEMPERATURE SODIUM SULFUR BATTERIES

THE TASK

For about 20 years sodium-sulfur batteries have been used for stationary electrical energy storage. There is plenty of sulfur and sodium available worldwide and thus the active materials in these batteries are inexpensive. A disadvantage of the technology is the temperature requirement of more than 300 °C to have both materials in liquid form, in order to achieve the cell reaction. This implies a low energy efficiency of the storage solution since it has to be heated. In addition liquid sodium poses substantial safety risks.

The theoretical limit for the specific electrochemical capacity of sulfur is 1672 mAh/g if the sulfur is completely discharged to Na₂S. This capacity is 7 times that of standard lithium ion cathode active materials. However, at high temperature the sodium-sulfur battery uses only about 25 % (418 mAh/g) of the theoretical capacity, because only polysulfides up to Na₂S₄ have a melting point below 300 °C. The formation of higher discharge products in the battery would lead to precipitation of such products and cause an irreversible capacity loss.

A sodium-sulfur battery that works at room temperature would have the advantages of inexpensive active materials and avoid the drawbacks of high temperature operation. The development of such a new battery type is part of the research project BaSta (project number: 0325563A). Five research institutes in Dresden collaborate on new components and manufacturing processes for room temperature Na-S batteries.

OUR SOLUTION

The key component of Dresden's solution is a carbon-sulfur composite electrode. The sulfur molecules are melted into the pores of the carbon material and thus are electrically connected. A solvent-free process creates freestanding electrode films from the carbon-sulfur composite powder and a binder. The use of toxic solvents and complex drying steps is avoided. A liquid electrolyte is used in the room temperature Na-S cell to transport sodium ions.

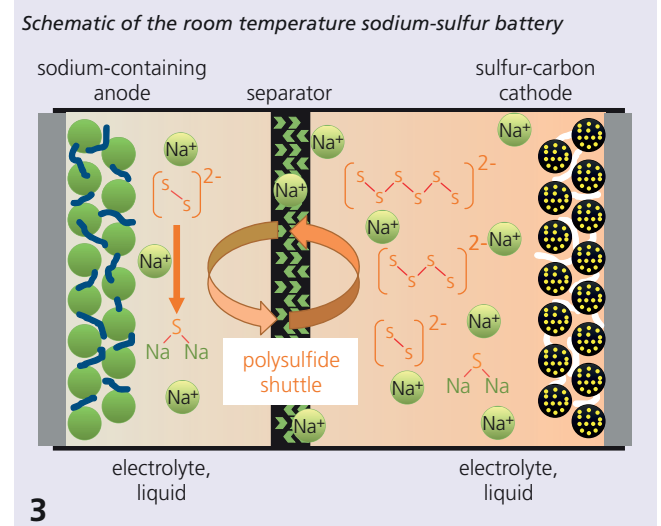

The cathode contains polysulfides. If these diffuse to the anode the cell degrades and the charging efficiency reduces. Therefore research is performed on barrier films for separator or anode to suppress polysulfide shuttle and avoid a polysulfide reaction with the anode.

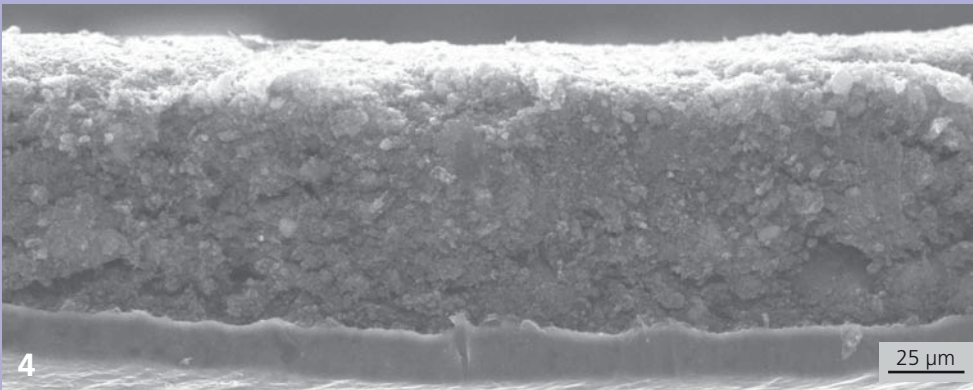

RESULTS

Sodium-sulfur cells with and without barrier coating were setup and tested at room temperature. The results demonstrate that discharge capacity and cycle stability drastically improve due to the barrier coating (Fig. 5). First cycles showed a specific capacity of more than 900 mAh/g or twice that of a high temperature Na-S cell. After 400 cycles the capacity still exceeded 400 mAh/g.

Cyclic voltammetric measurements showed that the polysulfide shuttle is quantifiably reduced due to the barrier coating (Fig. 6).

Sulfur discharge capacity versus cycle count, with and without barrier coating

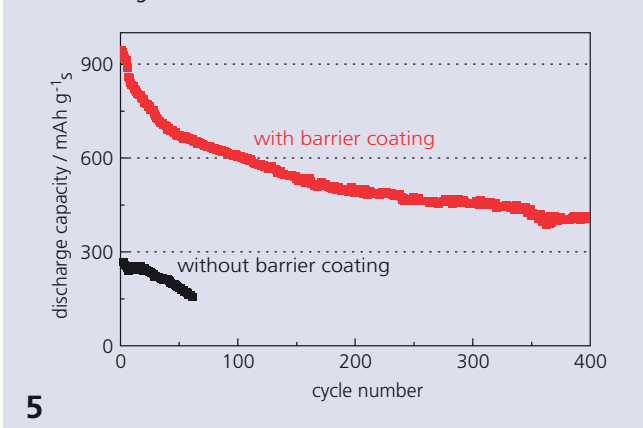

Shuttle currents for different barrier setups

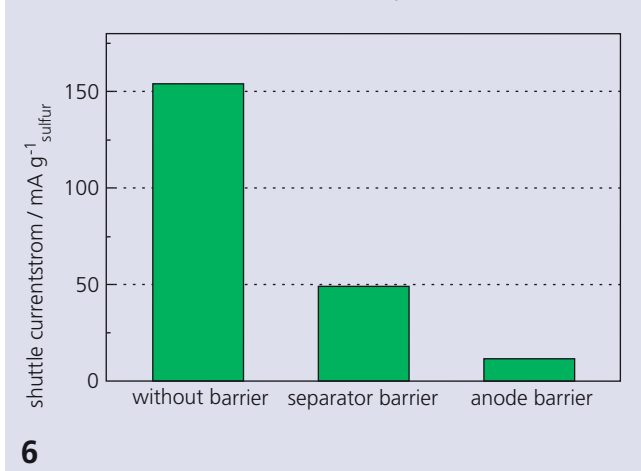

Manufacturing inexpensive energy storage devices requires not only widely available raw materials but also efficient and scalable manufacturing processes. The solvent-free fabrication of the cathodes is one step toward this goal. Additional production technology approaches are currently under investigation within the BaSta project. First results are described on pages 40/41 and 110/111.

- 1 Carbon electrode
- 2 Fraunhofer IWS pouch cell
- 4 SEM image of a carbon electrode in cross section

These first results prove the feasibility of sodium-sulfur batteries that can be operated at room temperature. Further development of key components and the cell systems will improve capacity and cycle stability.

CONTACT

M.Sc. Michael Kohl
 phone: +49 351 83391-3724
 michael.kohl@iws.fraunhofer.de



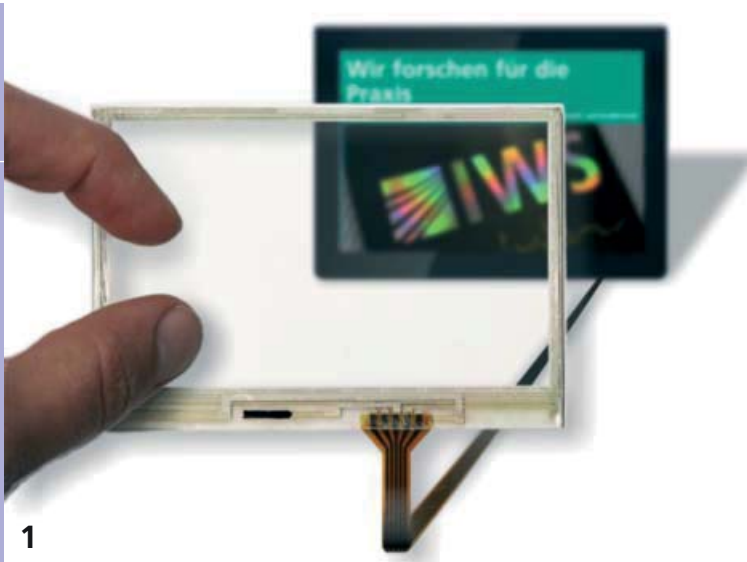

ROLL-TO-ROLL PROCESS FOR TRANSPARENT ELECTRICALLY CONDUCTIVE SURFACES

THE TASK

The finishing of polymer surfaces opens up new application fields and thus becomes increasingly interesting to the plastic processing industry sector. Transparent and electrically conductive foils have many applications in antistatic packaging and in electro optical components.

Conventionally, the desired electric surface properties were achieved through additives to the base material or by coating the foils in additional processing steps. Additives imply higher material consumption and potentially negative effects on the processability of the foils. They also may affect the properties of the plastic in a way that subsequent coating processes may require additional costs. Such coatings have to meet the highest standards while the deposition process windows are substantially limited due to the temperature sensitivity of the polymer. Technologies are required to overcome these limitations.

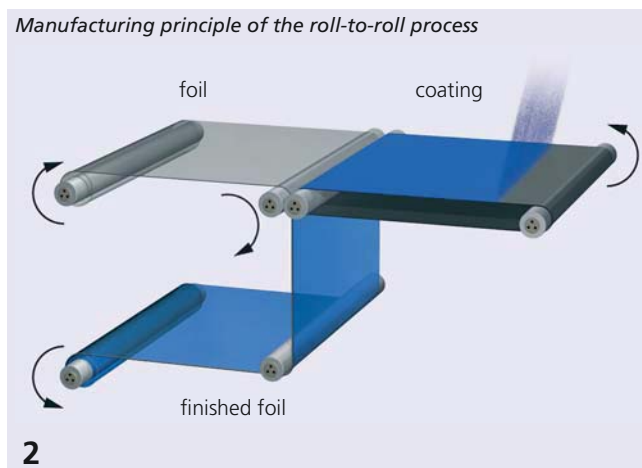

OUR SOLUTION

Fraunhofer IWS researchers have developed a new process to embed functional nanomaterials into polymer surfaces. The method solves the limitations of conventional surface refinement processes by separating the deposition process from the temperature sensitive polymer substrate. Existing coating processes (CSD, CVD) can be used with established processing conditions and temperatures to create highly conductive materials. The deposited coatings are later transferred onto the polymer foil (Fig. 2).

This transfer and embedding principle is useful in creating surfaces with a broad spectrum of properties and functions. Additional advantages are the low material consumption and the minimal influence on polymer properties.

The approaches were pursued to create electrically conductive and transparent polymer surfaces:

- transfer embedding of conductive **particles** such as ITO or silver
- transfer embedding of **networks** of silver wires or CNTs
- transfer embedding of **coatings** such as FTO or ATO

RESULTS

The transferred materials were abrasively tested to verify their mechanical stability. Fig. 3 shows the resistivity and transmittance of the different materials after the roll-to-roll transfer.

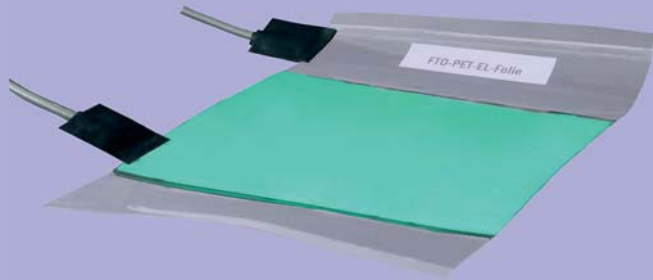

5

Transmittance and sheet resistance measurements of different materials that were transferred onto polymer foil

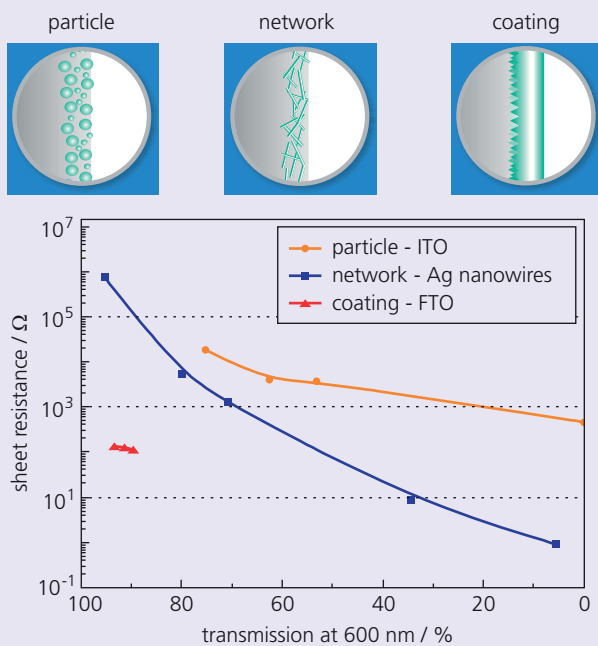

3

Fig. 4 shows a cross section SEM image of PET foil with embedded silver nanowires. The good connection and integration of the wires into the surface are visible.

SEM image of PET foil with embedded silver nanowires



4

A sheet resistance of > 100 kOhm is sufficient for antistatic applications. The resistance can be adjusted by embedding in the polymer surface conductive particles or networks made

from conductive nanotubes or wires. This method is very inexpensive and requires only minimal quantities (< 0.01 g per square meter) of material. Simple spraying processes from particle suspensions produce the temporary coating.

Electro optical components (electroluminescence, touch panel) require much lower sheet resistances (< 200 Ohm) and higher optical transmittance (> 85 %). Compact coatings have a higher cross sectional area for conduction compared to particles and networks. The lowest sheet resistance was achieved by transferring a FTO coating. The optical transmittance of the FTO-coating is caused by semi-conducting properties of the tin oxide. Thus for the first time it was possible to build touch panels and electroluminescence components based on FTO-PET foils (Fig. 1 and 5).

The results demonstrate the broad usability of the process with respect to the structure of the coatings that are transferred to the polymer surface. Additional inorganic functional nanomaterials help to engineer optical, electrical, chemical and mechanical surface properties of polymer foils.

The discussed demonstrators were created in a project funded by the BMBF (SubITO, project number: 033R082A).

- 1 Touch panel based on FTO-PET foil
- 5 Electroluminescent foil with transparent FTO-PET front electrode.

CONTACT

Dipl.-Ing. Thomas Abendroth
 phone: +49 351 83391-3294
 thomas.abendroth@iws.fraunhofer.de



1

RECYCLING OF PROCESS GASES WITH POROUS MATERIALS

THE TASK

Atmospheric pressure plasmas (AP) are very suitable to treat sensitive materials and can also be easily integrated into existing inline processes. So far these plasmas were primarily used to pretreat surfaces for cleaning and activation purposes. The deposition of coatings and nanoparticles based on AP processes is still a niche application of the technology. Compared to low pressure processes AP consumes inert gases, which enormously increases the costs of the process and hinders the technology from being more broadly used in these areas.

This is in particular true for the deposition of non-oxide coatings or the production of nanoparticles (e.g., SiC or Si₃N₄), which require expensive inert gases (e.g., argon) to create the plasma. To operate such systems economically requires recycling and reusing the gases. Surface activation processes can use pressurized air instead of inert gases. However, this creates nitrogen oxides, which smell bad and also pose health risks. Scrubbing the exhaust gases is thus essential.

OUR SOLUTION

A modular gas recycling system was engineered, which consists of a suction, filter unit and gas recirculation system. The system can be tailored to the specific requirements of various atmospheric plasma sources. Goals are the complete separation of nanoparticles by a filter and the efficient removal of gaseous byproducts from the effluent stream by adsorbing them on porous material (Fig. 2).

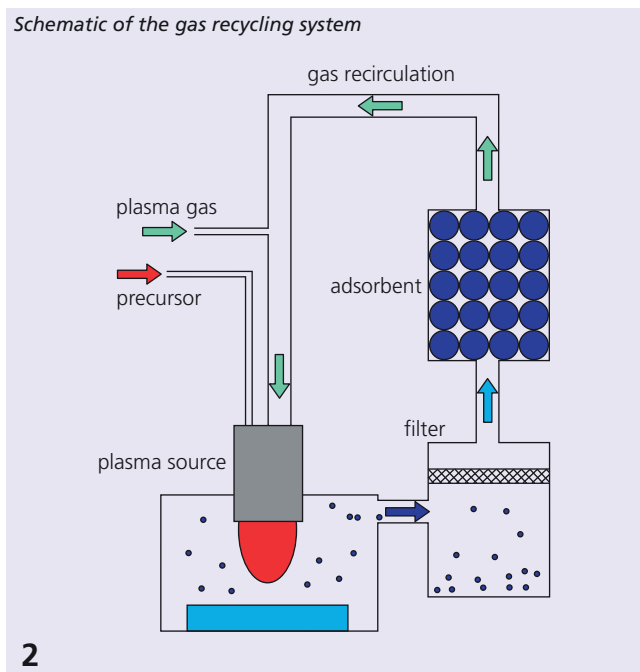

Cleaning the effluent stream by adsorption on porous materials first requires separating particles with a suitable particle filter. This prevents blocking of the pores, which in turn avoids a potential reduction of the adsorption capacity. The selection of the appropriate particle filter is based on the particle size distribution, which is determined by the help of a SMPS system (scanning mobility particle sizer).

The exhaust gas stream composition is determined using IR spectroscopy (FTIR). Based on the results it is decided which species have to be removed. Subsequently suitable adsorbents are selected and modularly integrated into the adsorbent cartridge.

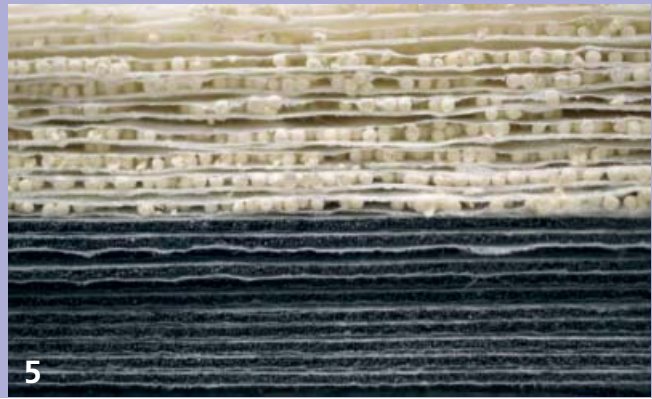

RESULTS

Data from particle and exhaust gas analyses were used to design the filter unit and the adsorbent cartridge of a specific AP process. There are numerous commercial adsorbents available such as zeolites and charcoal. Combining these different classes of porous materials removes gases of different characteristics (e.g., polar and non-polar substances, molecules with small and large diameters) from the exhaust gas mixture.

Commercial suction unit with different porous material with flat form factor

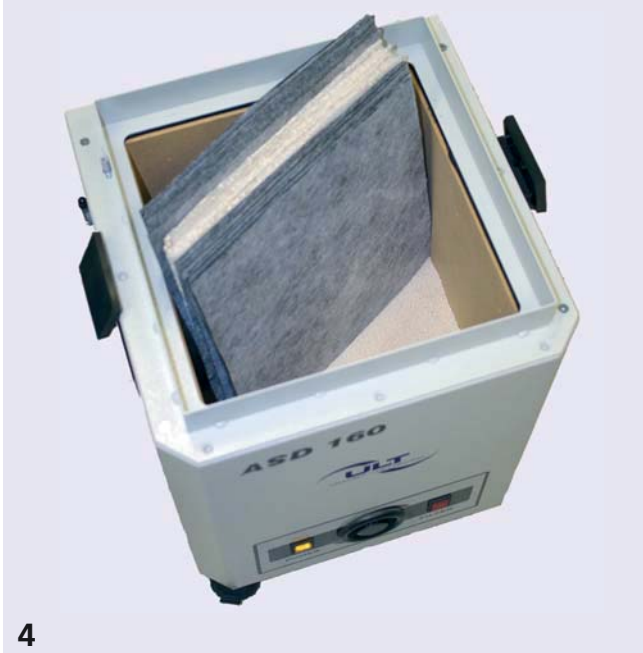

In addition to adsorbents it is also possible to include catalyzers. Catalytically active materials help to convert poorly adsorbing materials into substances that have better adsorptive properties. The arrangement of adsorbents and catalyzers in the cartridge can be in form of loose fills (Fig. 3) or with a flat form factor (Fig. 4 and 5). The use of such flat media makes it easy to simply exchange, receive or discard the saturated adsorbents.

Particle filters combined with the adsorbent cartridge clean the gas stream so that it recirculates back to the plasma nozzle during operation. This reduces the consumption of fresh process gases. This combination also serves as a cleaning unit to remove odors from the exhaust gas steam and eliminates health risks for the user.

- 1 Schematic of the adsorption process
- 3 Adsorbent fill (zeolite)
- 5 Adsorbent flat media (zeolite/charcoal)

CONTACT

Dr. Nicole Klein
 phone: +49 351 83391-3563
 nicole.klein@iws.fraunhofer.de



PLASMA BONDING OF POLYMER FOILS AT ATMOSPHERIC PRESSURE

THE TASK

Joining of polymer foils to build multifunctional units has great potential for applications in optics, microfluidics, environmental monitoring and process analytics. Especially the area of microfluidics has seen a revolutionary trend toward Lab-on-a-Chip solutions in analytical chemistry. The goal is to further miniaturize chemical analysis of liquids in life science applications. This enables high throughput screening analytics with minimized sample volumes.

Ultrasonic welding or adhesive bonding of specially prepared polymer foils are typical fabrication techniques to build Lab-on-a-Chip systems. Multilayer stacks are difficult to fabricate and the biocompatibility of the adhesives is often insufficient. Fraunhofer IWS researchers are therefore working on more effective and biocompatible joining technologies for polymer foils that are also suitable for large areas. These techniques are based on surface functionalization of polymer foils.

OUR SOLUTION

The developed bonding process for polymer foils does not require adhesives. Instead the foil surfaces are prepared with different functional groups. A subsequent bonding process triggers a chemical reaction between these groups, which creates a permanent bond.

The surface functionalization is accomplished with a special Fraunhofer IWS plasma process at atmospheric pressure. The polymer treatment occurs in high power plasmas created with a dielectric barrier discharge in combination with precursor gases for functionalization. The diluted precursor gases are transported with a carrier gas toward the vicinity of the polymer surface. There they interact with the argon plasma coming from the barrier discharge. After functionalization the gas mixture escapes to the exhaust.

To achieve a sufficient dissociation of the precursors, it required a redesign of the plasma electrodes and also increasing the frequency of the high voltage power supply of the plasma source. The length and the distance of the electrodes were optimized so that the foil is processed homogeneously across the full area. An undesired coating of the electrode is reduced by sheath streaming the precursors along the foil surfaces. This ensures that the foils can be treated in a long-term stable process.

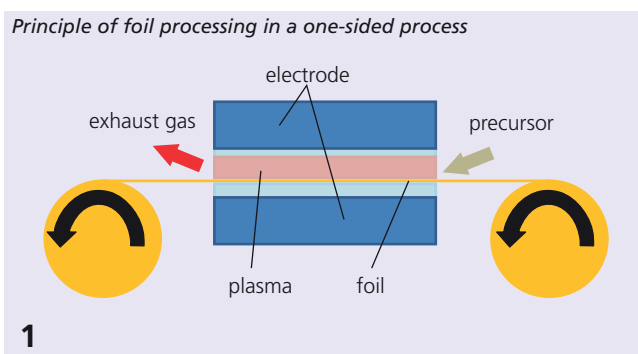

The IWS functionalization process has the following advantages:

- atmospheric pressure process (simple integration into existing systems to process foils)
- gentle and non-destructive foil processing
- simple scalability
- full area homogenous treatment
- front and backsides of the foil can be differently functionalized
- roll-to-roll process is possible
- laser structuring process can be added prior to functionalization in roll-to-roll process
- high efficiency / throughout, processing times are on the order of seconds
- use of non-toxic precursors

RESULTS

The developed functionalization process was applied to foils of different thicknesses. The cold plasma discharge is sufficiently gentle to not damage foils as thin as a few micrometers. Since the precursors are efficiently dissociated the processing times are only a few seconds.

After plasma treatment the foils are joined under light pressure. Due to the functionalization the foil surfaces are chemically reacting, which forms a long-term stable, bond resistant to liquids. The surface functionalization is also not sensitive to environmental influences. The joining process can be performed several hours after the functionalization without reducing the strength of the bond.

Plasma bonding of polymer foils is an ideal and inexpensive joining process for fabricating Lab-on-a-Chip systems. In collaboration with the IWS group working on laser microstructuring processes, the technology was used to build multilayer microfluidics systems. In addition to pneumatically actuated micro pumps and valves, the multilayer technology realizes fluidic structures and circular systems, which can reach across several layers within the biochip (pages 82/83).

Surface functionalization bonded the foils across large areas and forms a seal so that liquids cannot escape. It also creates optimized conditions to grow cell cultures for Lab-on-a-Chip applications. The technique saves or significantly shortens processing steps compared to conventional fabrication solutions.

2 *Plasma polymer foil processing with high power DBD (double-sided process)*

CONTACT

Dr. Gerrit Mäder
 phone: +49 351 83391-3262
 gerrit.maeder@iws.fraunhofer.de





1



AUTOMATED MATERIAL IDENTIFICATION BY SPECTRAL IMAGE ANALYSIS

THE TASK

The recycling of materials is one of the big challenges in current times as the costs for primary raw materials are constantly increasing. Polymers are very suitable for closed material cycles if they can be recovered at more than 99.9 % purity for re-use. An effective recycling process therefore requires a precise and automated material detection, classification and sorting system.

Requirements are increasing if the polymers are black in color. These are difficult to categorize with optical and spectroscopic methods. They mostly absorb incoming radiation and reflect only a very minimal fraction. In addition to the ability to classify these materials, the detection system has to be fast. Otherwise delays between detection and reaction (sorting) slow down the process.

OUR SOLUTION

Imaging spectroscopy based on hyperspectral imaging (HSI) can classify colored and black polymers that are transported by the same conveyor belt. The entire width of the conveyor belt is captured.

Hyperspectral imaging is principally very flexible since lenses, slit widths and working distances can be adjusted. However, the high data acquisition rates of more than 60000 spectra per second require powerful data analysis hard and software.

The HSI system was adapted to the requirements of automatically detecting and classifying black polymers. The preparation included a special illumination and adaption of the conveyor belt material. The material itself must not spectrally absorb since this would make detection of the polymers difficult. The recorded spectra are analyzed using specially prepared statistic models. The algorithms included support vector methods (SVM) and discriminant function analysis (DA).

Fraunhofer IWS researchers developed the software imantoPRO, which is processor-optimized. The software classifies the polymer particles in real-time. The information of each polymer particle (polymer type, time stamp and location) is delivered to a SPS unit, which controls the sorting.

Schematic of detection and classification

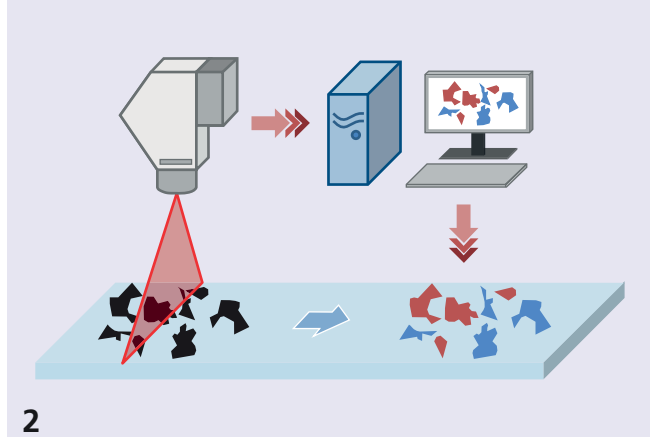

2

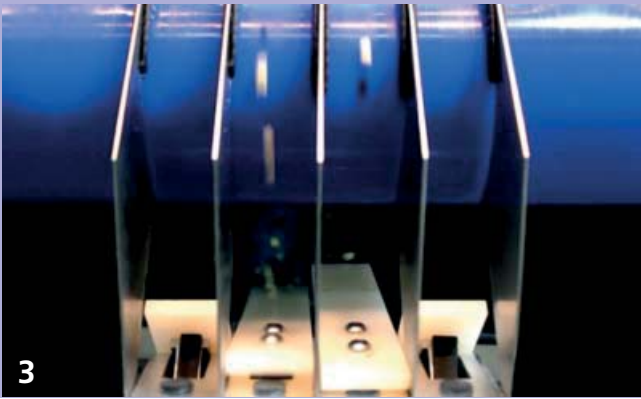

RESULTS

Powerful multivariate statistical detection methods solve challenges of sorting colorful and black polymers. The requirements for processing speed and polymer purity are achieved. Additional features such as the automatic recognition of the conveyor belt material and assessing the spectra quality are realized in real-time.

A pixel-by-pixel validation of the multivariate models shows that it is often not possible to directly achieve the required purity of the polymers. However, statistic certainty can be increased with increasing the number of pixels or spectra per polymer particle. The table below provides an overview of the results of model validations.

Results of the model validation of two different polymers

model	charge 1	charge 2
polymers	TPE white POM yellow TPE black	Pa66 black POM black
multivariate method	squared DA	SVM
prefiltered spectra	yes	yes
model validation (quality in %) (1 pixel)	98.4 %	88.5 %
number of pixels for purity > 99.9 %	2	4

4

Hyperspectral imaging is a powerful technique to automatically detect and classify objects. The technology is applicable to numerous different materials (polymers, glasses, metals, etc.) and sample configurations (single and multilayer systems). It can also be tailored to detect different features such as defects, impurities and material properties.

The measured data can be processed and used to fit various applications. For example, simple process control statements can be issued in an automated fashion. These can be used for process control algorithms to regulate sorting in recycling processes.

Sorting results from Model #1.
(Impurities are detected and removed from a flow of polymer particles. The desired product, pure POM in yellow is extracted.)
left: incoming polymer particles
right: sorted polymer particles "POM yellow"

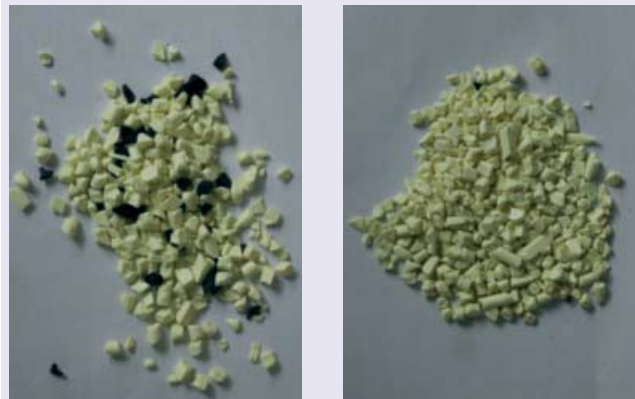

5

- 1 Different polymer fractions, the individual materials are used to define the model
- 3 Example of a system to sort polymers

CONTACT

Dr. Philipp Wollmann
phone: +49 351 83391-3316
philipp.wollmann@iws.fraunhofer.de



CENTERS



CONCENTRATION ON SPECIFIC EXPERTISE

The IWS competence centers are established to bundle expert knowledge and responsibility in research fields, which are of strategic relevance for the institute.

Tailored Joining – Concentrated competence in Dresden	124
IWS battery research – Technologies for new energy storage systems	125
Energy efficiency – We are not finished yet!	126
Additive manufacturing – Competence in materials and manufacturing engineering	127
Nano in focus – The nanotechnology center	128
Nanotubes and nanoparticles – Small parts with great effect	129
Carbon technology – Unique variety at Fraunhofer IWS	130
Fiber composite technology – Technologies for modern lightweight construction	131
Laser integration in manufacturing	132
Process monitoring and sensor technology – Committed to quality	133
Research of terabytes – Competence in data management	134
Smart systems in focus of medical and biosystems engineering	135

Furthermore the IWS operates centers at different sites, which concentrate on the current level of knowledge and expertise and evaluate market potential and trends for future research demands.

Dortmunder Oberflächencentrum (DOC®)	136
Project Center Laser Integrated Manufacturing in Wrocław (PCW)	138
Fraunhofer-Center for Coatings and Laser Applications (CCL)	140

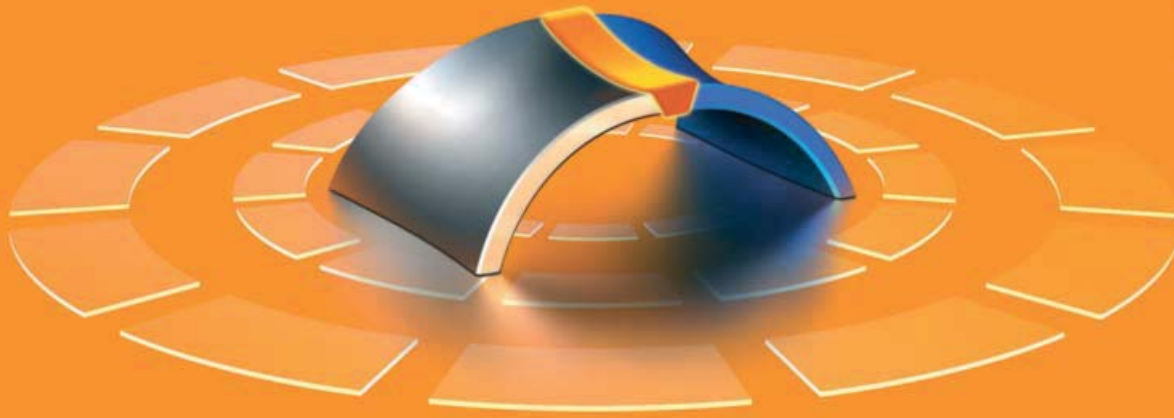

TAILORED JOINING – CONCENTRATED COMPETENCE IN DRESDEN

Joining is a central production challenge and also a significant cost factor. In many cases current joining technology developments offer significant improvements and impulses. Therefore the Fraunhofer IWS in cooperation with the TU Dresden and other partners established the joining technology center “Tailored Joining”. The center is designed to provide an overview to users of joining technology, to show the different processes as well as their advantages and limitations. New developments are presented and industrial solutions shown.

The basis of the center is formed by the enormous bandwidth of available joining technologies in Germany and also internationally. IWS performs research on all of these methods:

- laser beam welding
- laser hybrid processes (plasma, arc, induction)
- laser brazing (hybrid) and reactive multilayers
- magnetic pulse welding (forming + welding)
- friction stir welding
- frictionally engaged laser welding (web-slot connections)
- diffusion welding (laser induction roll plating)
- adhesive bonding

Our partners at the “Chair Joining Technologies and Assembly” at the TU Dresden concentrate their research work on processes and tools in the field of thermal joining (arc welding, brazing), forming, mechanical joining (screwing and pressing) and hybrid joining. The scientists focus their work on the comprehensive planning of processes for installation, handling and joining processes.

COORDINATION

DR. JENS STANDFUSS

phone +49 351 83391-3212
jens.standfuss@iws.fraunhofer.de



PUBLIC RELATIONS

CLAUDIA ZELLBECK

phone +49 351 83391-3332
claudia.zellbeck@iws.fraunhofer.de



www.iws.fraunhofer.de/joining

Since 2014 the Hochschule für Technik und Wirtschaft (HTW) Dresden has actively supported our center with its expertise in the field of electron beam technology.

Special effort is spent on presenting a fair comparison of the various solutions. The goal is to provide the user with insightful help when selecting which technology best meets the application’s needs.

The International Joining Symposium “Tailored Joining” has excellently proven itself as a platform for the exchange of experiences. The next symposium will be held within the framework of the International Laser Symposium “Fiber, Disc & Diode”, on February 23rd – 24th, 2016. The huge variety of current joining procedures and their developments will be presented and discussed. In addition, the symposium will offer practical demonstrations in our partners’ laboratories, providing newcomers with the opportunity to quickly become familiar with new technologies and to evaluate their limits and possibilities.

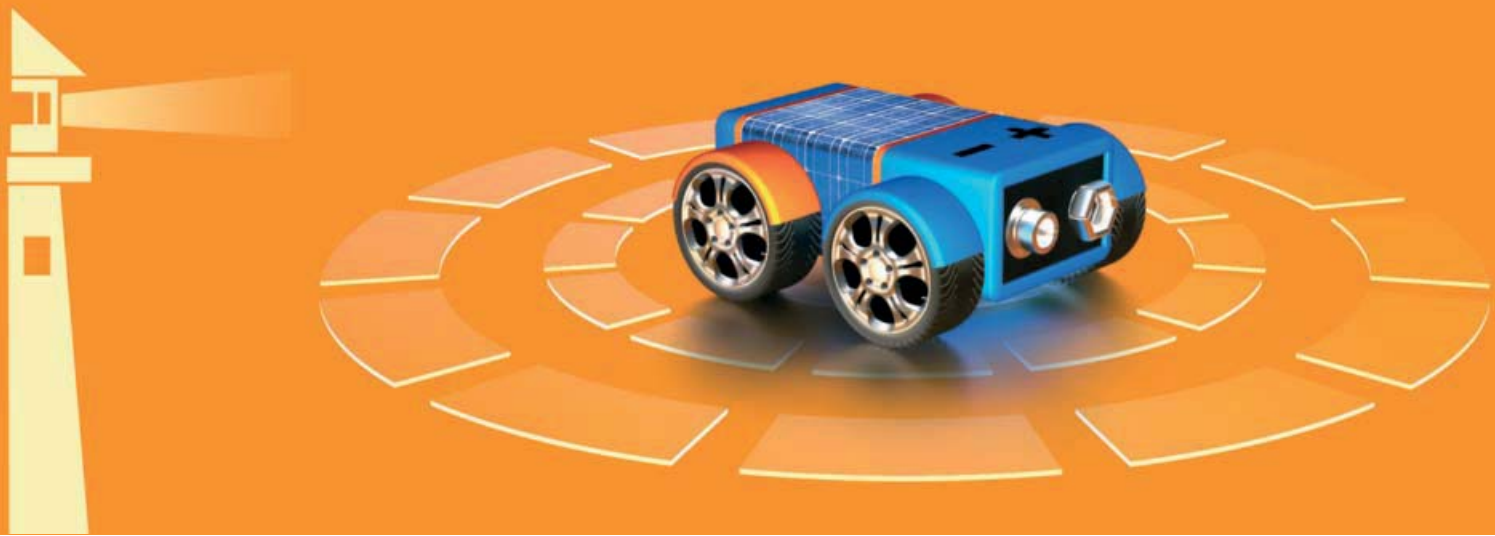

IWS BATTERY RESEARCH – TECHNOLOGIES FOR NEW ENERGY STORAGE SYSTEMS

Numerous research projects addressing the development of storage solutions and other energy storage applications in the area of electromobility emphasize the key role of the Fraunhofer IWS in Dresden. The battery manufacturing demonstrator line, developed at the IWS, contributes essential knowledge to a more efficient in-house development. Our scientists are now able to comprehensively provide support to industrial enterprises in their research into battery materials.

This year, a demonstrator for electrode cutting and transport processes with continuous material feed has been developed and set up within the BMBF-funded DryLIZ project (BMBF: KIT 02PJ2302). It excellently complements the already existing system for the automated, accurate stapling of battery electrodes and separators. A continuous feed of the electrode to the stapling device is guaranteed and thus, a decisive reduction of machining time is achieved. The electrodes can now be processed and stapled directly after the cutting process.

Primarily publically funded projects advance the further development of materials and technologies.

CryPhysConcept (BMW/BMWi/BMBF: FZJ 03EK3029B)
 With crystal physics to future concepts of electrochemical energy storage systems
 Timeframe: 10/2012 - 12/2015

BaSta (BMW/BMWi: FZJ 0325563A)
 Battery – Stationary in Saxony
 Timeframe: 11/2012 - 10/2015

BatCon (BMW/BMWi: DLR 01MX12055C)
 Functionally integrated high current connectors for battery modules, Timeframe: 01/2013 - 12/2015

COORDINATION

MATERIALS DEVELOPMENT

DR. HOLGER ALTHUES

phone +49 351 83391-3476
 holger.althues@iws.fraunhofer.de



MANUFACTURING TECHNOLOGY

DR. PHILIPP THÜMMLER

phone +49 351 83391-3215
 philipp.thuemmler@iws.fraunhofer.de



www.iws.fraunhofer.de/battery

PLIANT (EU: FP7-NMP-2012-LARGE-6)
 Process Line Implementation for Applied Surface Nanotechnologies
 Timeframe: 01/2013 - 01/2017

BamoSa (BMBF: FZJ 03X4637A-H)
 Battery – mobile in Saxony
 Timeframe: 06/2013 - 05/2016

LiScell (Fraunhofer internal preliminary research project)
 Safe lithium-sulfur cell with 400 Wh/kg and 1000 cycle stability
 Timeframe: 06/2014 - 05/2017

In 2015 the 4th workshop “Lithium-Sulfur Batteries” will take place within the framework of the Dresden Conference “Energy in Future” at the International Congress Center Dresden, 10 - 11 November, 2015.

More at www.zukunftenergie-dresden.de/en

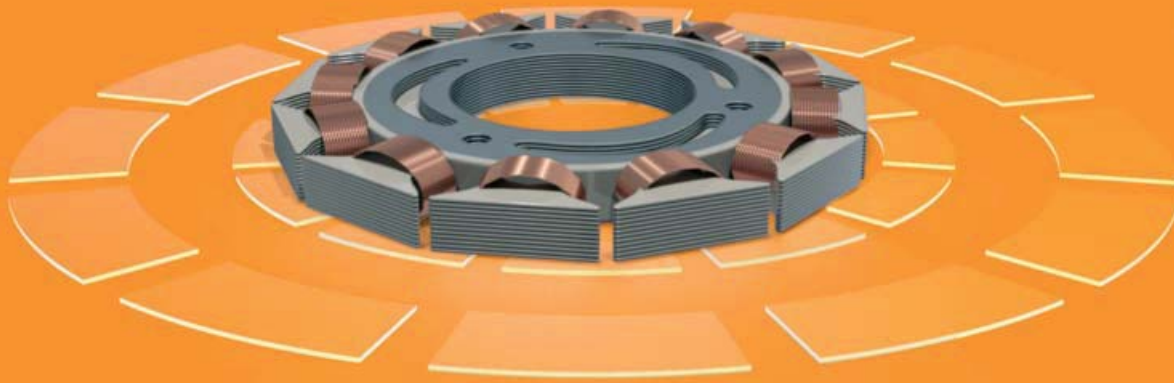

ENERGY EFFICIENCY – WE ARE NOT FINISHED YET!

The Fraunhofer IWS focuses its research on the advancement of resource-saving technologies and on the economical use of energy. Right from the beginning the IWS has implemented numerous technologies into industrial applications, which have benefited society and enterprises as a whole. One example is the development of a novel local heat-treatment technology, which is able to increase the energy-related efficiency of steam engines.

Another example is the IWS-developed laser welding technology applied for belly pod areas of different Airbus models enabling a significant decrease of the structure weight. In the case of the models A340 – 600 it became possible to save nearly 100 kilograms. With regard to primary structures our welding technology can even save up to 10 % weight.

The laser welding process has become nearly indispensable in mass production processes of car transmission parts. Considerable savings in terms of fuel and better energy efficiency have been achieved. Particular IWS friction-reducing coatings on motor components open up a novel way for fuel reduction. The IWS technology, in combination with the Diamor® deposition system is well on its way to a broad industrial application.

In 2009 the IWS-coordinated center “Dresdner Innovationszentrum Energieeffizienz DIZE^{EFF}” was founded to advance the future topic “Energy efficiency” beyond its existing limits and to speed up innovations for the local economy.

SPOKESMAN

PROF. ECKHARD BEYER

phone +49 351 83391-3420
eckhard.beyer@iws.fraunhofer.de



COORDINATION

DR. STEFAN SCHÄDLICH

phone +49 351 83391-3411
stefan.schaedlich@iws.fraunhofer.de



www.iws.fraunhofer.de/energy

The center joins scientists of the TU Dresden and of the Fraunhofer Institutes in numerous projects, which focus on highly efficient solar cells, fuel cells, high-temperature energy technology, lightweight construction and energy-saving displays.

Current IWS developments focus on energy-harvesting processes through thermoelectric generators as well as on the reduction of magnetic losses in electric motors. Recent developments and research results will be presented at the Hannover Messe Industrie 2015 and at the IWS conference “Energy in Future”.

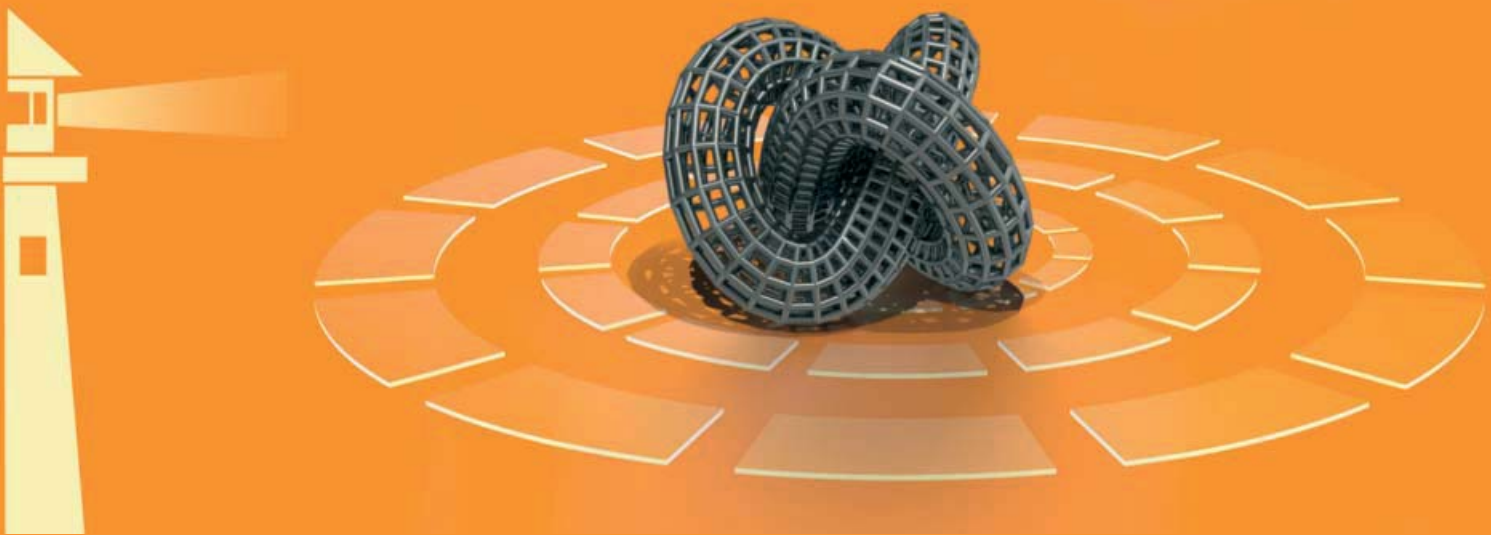

ADDITIVE MANUFACTURING – COMPETENCE IN MATERIALS AND MANUFACTURING ENGINEERING

Additive manufacturing technology has led to a paradigm shift in manufacturing engineering. Thanks to the layer-by-layer generation material is only applied at the area where it is needed. The new manufacturing technology allows degrees of freedom for functional optimization and flexibility not seen before, beyond the limits of conventional manufacturing technology. There is a correspondingly high industrial interest in qualifying the additive manufacturing to a high industrial level.

The high potential of additive manufacturing is opposed to the large variety of unsolved issues. These issues can only be solved in a close collaboration between science and industry. Fraunhofer IWS initiated the project "Additive Manufacturing – Agent-3D" to advance the required collaboration. The consortium with its 60 partners establishes a strong network between industry and research organizations.

Within the framework DRESDEN-concept the scientists, together with partners of the TU Dresden, founded an internationally recognized competence center, in which material and manufacturing solutions for challenging products are interdisciplinarily developed. Presently the scientists focus on research fields such as aerospace, automotive industry, tool making, energy technology and medical engineering. In a rapidly developing high technology field the center offers an excellent networking platform for economy, scientific basic research and application-oriented research.

COORDINATION

PROF. CHRISTOPH LEYENS

phone +49 351 83391-3242

christoph.leyens@iws.fraunhofer.de



COORDINATION

DR. ELENA LOPEZ

phone +49 351 83391-3296

elena.lopez@iws.fraunhofer.de



www.iws.fraunhofer.de/additivemanufacturing

Our process portfolio includes

- laser buildup welding with wire and powder
- selective laser melting
- electron beam melting
- 3D printing technology

for metallic and intermetallic materials, polymers, functional materials and multi-material systems. With regard to procedures we offer developments for processes, for system and sensor technologies, and for on-line process diagnostics.

The research work of the center focuses on product chains comprising: component design, finishing and processing steps, repair and recycling. Testing and characterization of material and components produced with additive manufacturing technologies belong to the core competences as well.



NANO IN FOCUS – THE NANOTECHNOLOGY CENTER

Nanotechnology offers innovation and delivers important contributions to energy and resource efficiency. It is a cross sectional technology overarching many branches. A close cooperation between research organizations and companies is required to faster and better utilize nanotechnologies in applications. The Fraunhofer IWS has been actively participating in this effort for years. Activities include internal research work as well as the coordination of and participation in numerous initiatives.

Research works at the IWS in this field address in particular:

- ion beam processing of optics (pages 100/101).
- multilayer Laue lenses for high resolution X-ray optics (pages 104/105).

These topics are of increasing interest for industrial applications.

For the 10th time the Fraunhofer IWS, together with the City of Dresden, organized the International Nanotechnology Symposium “Nanofair – new ideas for industry” held in Dresden on July 1st to 3rd 2014. The program included more than 65 presentations and contributions from renowned international experts. 350 participants from 35 countries vividly followed the program as well as the poster session. Topics covered such subjects as nanomaterials and nanocomposites, Life Science applications, organic and printed electronics and new aspects in nanoanalytics. The Fraunhofer IWS is actively engaged in transferring research results to manufacturing. That is the reason why the institute has participated in the “nano tech” fair in Tokyo, Japan for years. Furthermore, fair trade presentations at the PSE in Garmisch-Partenkirchen addressed this topic.

COORDINATION

PROF. ANDREAS LESON

phone +49 351 83391-3317

andreas.leson@iws.fraunhofer.de



www.iws.fraunhofer.de/nanotechnology

In addition the IWS continues to be actively involved with the initiative “Nano in Germany”, which joins more than 120 enterprises and institutes. Prof. Andreas Leson was elected as their spokesman for a further two years. Prof. Leson is the Deputy Director of IWS Dresden and also head of a business unit at the institute. He was honored for his outstanding dedication with the award “A Life for Thin Film” in 2014.

The IWS Dresden coordinates the nanotechnology competence center “Ultrathin Functional Coatings”, is also a member of the Fraunhofer Alliance Nanotechnology, participates in Dresden’s cluster for nanoanalytics and in the network “Organic Electronics Saxony”.

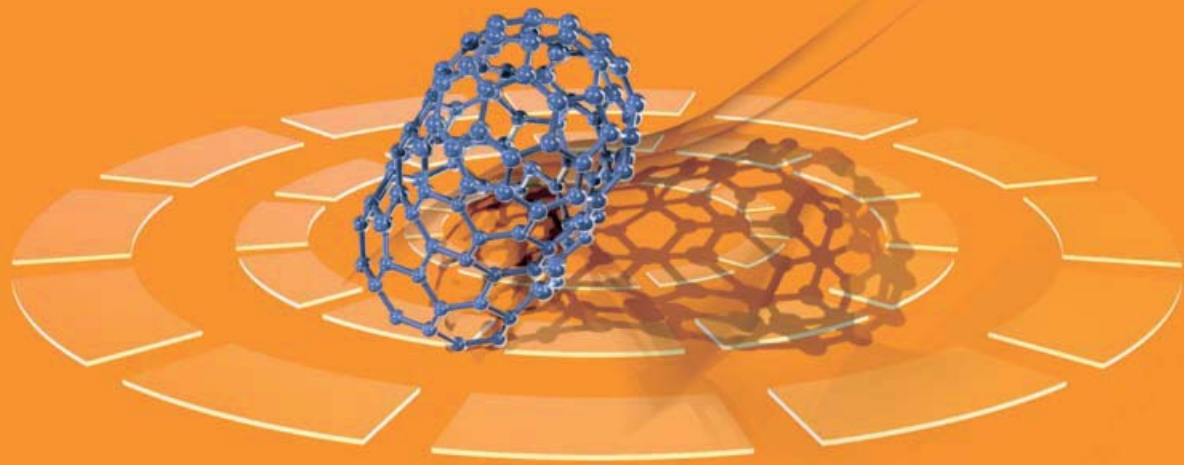

NANOTUBES AND NANOPARTICLES – SMALL PARTS WITH GREAT EFFECT

Due to their large surfaces, nanoparticles show a different chemical and physical behavior than materials with macroscopic structures. This feature enables a decisive improvement of the characteristics of composite materials by targeted embedding nanoparticles into the corresponding matrix. The scientists of the Fraunhofer IWS focus their research on the fabrication of carbon nanoparticles and their competences comprise:

Fabrication of Single Wall Carbon Nanotubes (SWCNTs):

- development of a procedure for a scalable, cost-saving gas phase synthesis of SWCNTs, which is unique in the world
- development of an IWS pilot line for a large scale SWCNT production (kg/day) for the fabrication of semi-conducting and metal SWCNTs with up to 90 % purity
- online monitoring of SWCNT gas phase synthesis
- development of a process to deposit vertically aligned CNTs on surfaces (in cooperation with the TU Dresden)

Preparation of SWCNTs:

- cleaning of SWCNTs (removal of amorphous carbon and catalyst particles)
- functionalization of SWCNTs
- dispersion of SWCNTs in aqueous surfactant solutions or organic solvents for direct applications (spraying) on surfaces

Fabrication of nanoscale carbon black particles:

- development of solar thermal processes (no CO₂ emission) to fabricate carbon black of a defined structure size as a by-product of hydrogen production

COORDINATION

DR. GERRIT MÄDER

phone +49 351 83391-3262
gerrit.maeder@iws.fraunhofer.de



PUBLIC RELATIONS

DR. RALF JÄCKEL

phone +49 351 83391-3444
ralf.jaekkel@iws.fraunhofer.de



www.iws.fraunhofer.de/nanoparticles

Possible applications of the nanoparticles are:

- transparent conductive layers
- flexible conductive layers
- antistatic surfaces
- flexible conductive polymers
- optical absorbing layers for high temperature range

The Fraunhofer IWS was a member of the innovation alliance Inno.CNT cooperating with 90 renowned partners from science and industry. Thus the potential of SWCNTs could be perfectly utilized and transferred into industrial applications.



CARBON TECHNOLOGY – UNIQUE VARIETY AT FRAUNHOFER IWS

Carbon is a special element with extraordinary versatility. Its various modifications and compounds have a broad property and applications spectrum. For years carbon has played a central role in Fraunhofer IWS research. Here are some examples:

Diamond-like carbon (ta-C) to reduce friction and wear is an important research focus in the business unit PVD and Nanotechnology. For many years the research has addressed the link between coating properties and deposition process. Now the Fraunhofer IWS developed systems technology to deposit ta-C has found its way to industry. Two industrial applications could be implemented in 2014 (pages 44/45).

Graphite-like carbon (GLC) has predominantly graphitic bonds and thus an associated high electrical conductivity. IWS engineers use a modified deposition technology to synthesize these coatings. They are characterized by a low contact and a high chemical corrosion resistance. A special laser structuring process is also used to locally graphitize diamond-like coatings (pages 92/93).

Carbon nanotubes (CNTs) are characterized by their high electrical conductivity. Vertically aligned carbon nanotubes serve as conductive and binder free matrix for contacting sulfur in lithium-sulfur batteries. IWS engineers produce single wall carbon nanotubes in a gas phase, which are increasingly used in sensor and actuator applications.

Thin CNT-coatings enable the fabrication of transparent, conductive layers with high flexibility and actuator characteristics. By integrating CNTs into polymer surfaces IWS scientists could improve their anti-static features.

COORDINATION

PROF. STEFAN KASKEL

phone +49 351 83391-3331
stefan.kaskel@iws.fraunhofer.de



PUBLIC RELATIONS

DR. RALF JÄCKEL

phone +49 351 83391-3444
ralf.jaekkel@iws.fraunhofer.de



www.iws.fraunhofer.de/carbon

Carbon fibers are another highly topical subject. IWS scientists' research focus includes coating processes of carbon fibers with respect to their integration into polymer matrices as well as cutting and joining process steps for carbon-reinforced polymers.

Mono and polycrystalline diamond is of great interest for optical, X-ray optical and electronic applications. At Lansing, MI, USA subsidiary Fraunhofer CCL, IWS produces diamond from the vapor phase by homoepitaxial chemical vapor deposition (pages 38/39).

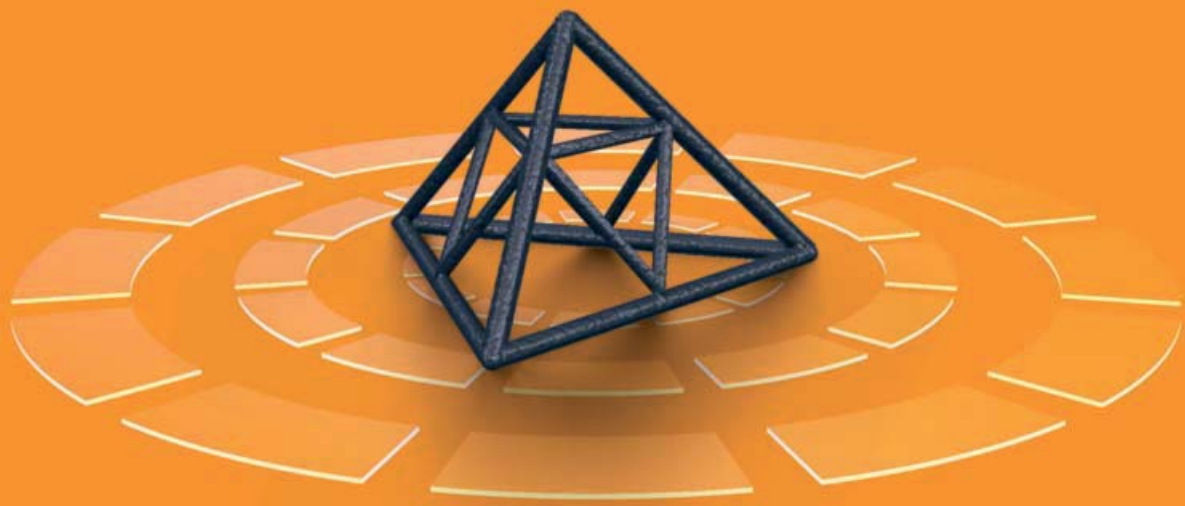

FIBER COMPOSITE TECHNOLOGY – TECHNOLOGIES FOR MODERN LIGHTWEIGHT CONSTRUCTION

Lightweight structures, consisting of fiber composite materials and tailor-designed part geometries can excellently meet the demanding requirements regarding energy-saving products. To reduce the costs for these structures, the scientists of the Fraunhofer IWS Dresden and experts from the Technische Universität Dresden focus their work on optimizing this manufacturing process chain. Among others their foci include:

- controlled heat input through minimization of the interaction time with simultaneously high ablation rates using ultra-short pulsed lasers
- near-net-shape processing of consolidated and unconsolidated materials using the laser remote technology (remocut®FRP)
- generation of form-fitting joints applying generating and ablative procedures
- structural adhesive bonding of composite parts
- adhesive and laser fixing of fiber reinforced semifinished products
- inductively assisted adhesive bonding
- optimized material joining of hybrid components through tailored processing of contact areas by applying laser and plasma pretreating
- generation of reactive nanometer multilayers for high speed joining processes of thermoplastic fiber reinforced parts
- laser assisted processes for the continuous carbonizing of stabilized precursor fibers for carbon fiber fabrication
- application of microwave radiation and microwave plasma for energy efficient carbon fiber fabrication
- fabrication of polymer fibers with diameters between 50 nm and 1 µm with integrated nanoparticles (e.g. carbon nanotubes)

COORDINATION

ANNETT KLOTZBACH

phone +49 351 83391-3235
annett.klotzbach@iws.fraunhofer.de



www.iws.fraunhofer.de/composite

A close cooperation in the field of fiber composite technologies is intensified by the active involvement in the special collaborative research project SFB 639 (textile reinforced composite components for functionally integrated mixed constructions).

Thanks to the membership in the association "Carbon Composite e.V.", the scientists benefit from a lively exchange of ideas with experts from regional enterprises and other research organizations. The research results of several departments were successfully presented at the different national and international expert tradeshows and conferences.



IWS joint booth together with Held Systems at the Composite Europe in Düsseldorf

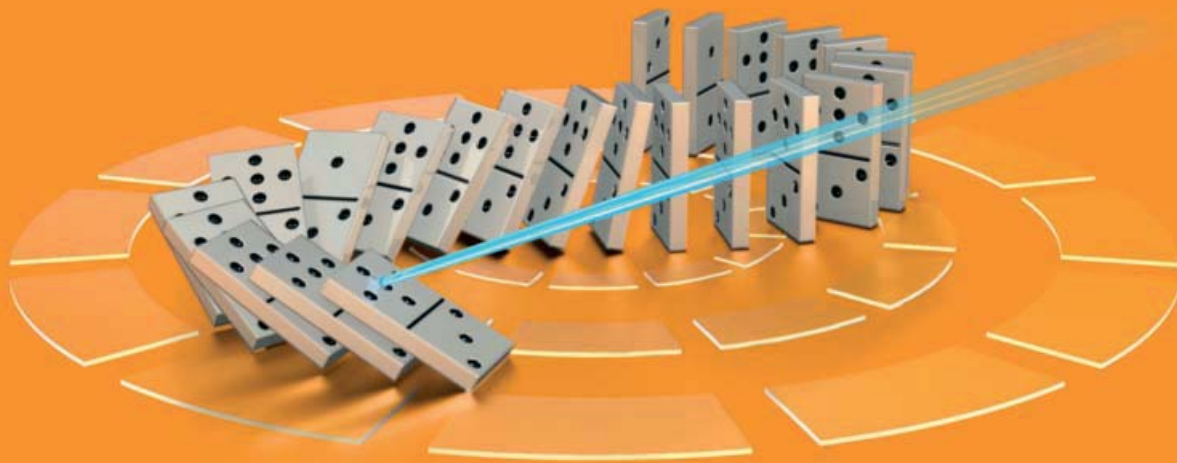

LASER INTEGRATION IN MANUFACTURING

For many years the Fraunhofer IWS has aimed at increasing the competitiveness of Germany's machine and plant building industry by providing laser technology. Dresden's researchers have already delivered numerous innovative technologies and systems to industrial customers. A special brochure compiled a selection of such successes, which was issued for the 20th anniversary of the institute.

The institute's activities continue to be driven by branch overarching applied research for industry. IWS networks and collaborations with other research institutions and industrial partners are concentrated within the center for laser integration in manufacturing. The goal is to offer customers "one step" solutions.

The advantages for machine and plant builders as well as manufacturers are evident:

- cost savings due to reduced process chains,
- higher efficiency of the manufacturing processes and products,
- higher efficiency of the manufacturing processes and products,
- competitive advantages at the highest technical level.

The implementation of the laser MSG hybrid welding system for longitudinal welding processes of mobile crane components and the application of the highly dynamic form cutter for sheet cutting processes were our latest technology transfers. In addition, the first industrial application of the highly efficient remote cutting technology for sheet parts and another laser buildup welding and hardening systems for large tool making could successfully be transferred into industrial applications. Further implementations of the year 2014 can be found on page 8 and 9.

COORDINATION

DR. STEFFEN BONSS

phone +49 351 83391-3201
steffen.bonss@iws.fraunhofer.de



PUBLIC RELATIONS

CLAUDIA ZELLBECK

phone +49 351 83391-3332
claudia.zellbeck@iws.fraunhofer.de

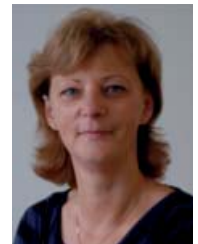

www.iws.fraunhofer.de/en/laserintegration

IWS developed technologies are to be transferred into practical and cost-effective solutions as quickly as possible. To bridge the gap between science and economy and to address a broad professional audience IWS scientists exhibited their recent developments at national and international trade shows. Examples include the Hannover tradeshow, the Airshow ILA, Lasys, Parts2clean, the EuroBlech and the EuroMold.

The 9th International Laser and Tailored Joining Symposium, held at the International Congress Center in Dresden on February 27th and 28th 2014, was a particular highlight. Already the preliminary Open House invitation welcomed numerous visitors who were looking forward to visiting our IWS laboratories. They continued their expert discussions within the subsequent symposium with its 460 participants and the well-attended exhibition.

More at www.lasersymposium.de/en



PROCESS MONITORING AND SENSOR TECHNOLOGY – COMMITTED TO QUALITY

One central task in modern industrial production processes is to monitor the processes and to analyze the products during and after fabrication. Thus new production technologies increasingly include the development of appropriate process analytical sensors, measurement methods and devices.

The IWS center for process monitoring and sensor technology focuses on the development of optical and optical-spectroscopic sensors and their implementation in the field of laser and surface technologies.

Specially developed monitoring techniques help to derive information about laser processes (temperature, beam analysis), product characteristics (surface, layers, composition, porosity), and process atmospheres (gas composition) in a non-contact and highly sensitive manner. The results obtained are applied for automated monitoring, control and for the optimization of processes. Apart from adaptations to existing technologies, novel sensor technologies are being developed up to the point where they can be commercialized. Based on many years' experience the IWS scientists rely on their comprehensive expertise.

Foci for the monitoring of laser processes are:

- high-speed temperature monitoring of laser hardening and cladding processes (E-MAqS / E-FAqS)
- measurement and control systems for temperature monitoring (LompocPro)
- laser beam analysis for quality control of optics and laser sources (LasMon)
- plasma spectroscopy for laser welding tasks

COORDINATION

DR. WULF GRÄHLERT

phone +49 351 83391-3406

wulf.graehlert@iws.fraunhofer.de



www.iws.fraunhofer.de/processcontrol

Furthermore optical-spectroscopic procedures are applied to perform single-point measurements as well as 100 % checks. Procedures such as IR, RAMAN, UV/VIS and laser spectroscopy are excellently suited for manifold tasks in the field of process monitoring. Most modern "Hyperspectral Imaging" systems are used for a 100 % monitoring.

Development priorities for optical-spectroscopic measurement techniques are:

- optical calorimetry for the analysis of porous materials (InfraSORP®)
- determination of water vapor permeation rates of ultra-barrier materials (HiBarSens®)
- imaging analysis tools (hard and software) for Hyperspectral Imaging (imanto®)
- infrared based in-situ multi gas analysis (ISPRoM®)
- laser diode spectroscopic trace gas analysis (TraceScout)



RESEARCH OF TERABYTES – COMPETENCE IN DATA MANAGEMENT

Data management and the responsible handling of data are essential topics in medicine, Life Science and production processes. The management of data (e.g. test results) take up a quarter of researcher's working time. Additionally different laboratory devices provide different data types and an overview is quickly lost. Even companies have long been applying the digital revolution. Cyber-physical systems connect processes, products, media, and operators via internet. These IT-systems are tested at laboratory scale at the IWS.

The competence center "Data Management" is a cooperation with the TU Dresden and the University Hospital Dresden. Methods for big data and interactive assistance systems are jointly developed. The focus of the research is on digital data used for early recognition, temperature measurements, diagnostics, therapy schedule, therapy support and therapy success monitoring. Research and development range from image acquisition to image processing, modeling and visualization to user-interface and application design.

Competence profile of the IWS:

- development of image database and technologies
- image processing and 3D visualization
- process optimization for data management and storage in databases
- development of bio-medical image file formats
- software development for modelling, architecture, analysis
- data management and data storage
- visualization, visual analytics
- development of technology and data standards for the management of digital images and metadata

COORDINATION

PROF. KAROL KOZAK

phone +49 351 83391-3717

karol.kozak@iws.fraunhofer.de



www.iws.fraunhofer.de/datamanagement

Complementary partner competence profile in the field of professional software development and consulting:

- object-oriented programming languages: J2EE, NET, Python
- InMemory databases
- mobile application: InMemory: iPhone, Android, WindowsPhone
- professional project management: Scrum-Agile Model
- IT and software architecture modeling

In the field of data management and evaluation:

- development of technology and data evaluation for the management of digital images and metadata
- automated real-time data processing and management
- multi-parametric and statistical evaluation, visualization, management
- visual analytics

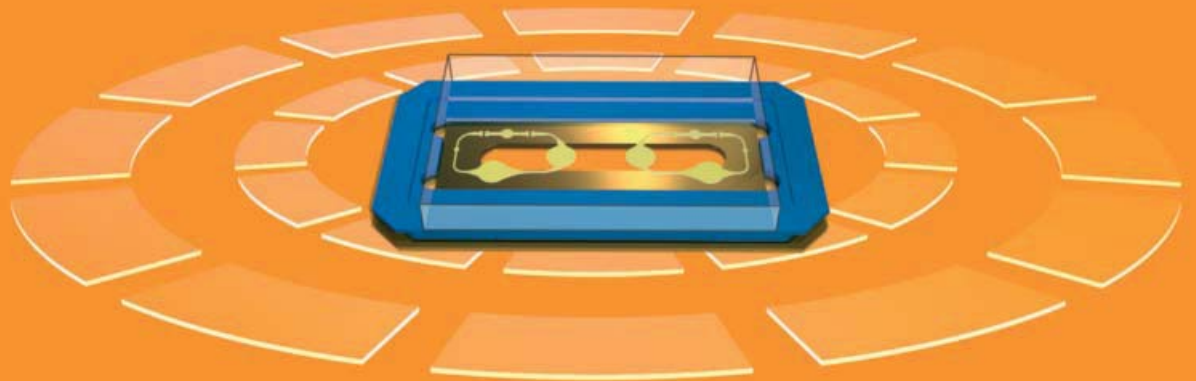

SMART SYSTEMS IN THE FOCUS OF MEDICAL AND BIOSYSTEMS ENGINEERING

In the field of medical and bio systems engineering the laser is a firmly established tool and laser processing applications are increasingly advancing. The scientists of the Fraunhofer IWS Dresden offer a comprehensive overview about the possibilities and limits of technical systems, produced by laser technologies in the field of biotechnology, environmental biosensors and cell culture technology. New developments and industrial solutions are to be presented and explained.

Complex cell culture experiments are indispensable for developments in the field of regenerative and personalized medicine. For this reason scientists of the IWS have been developing a microfluidic system which is actuated by integrated micro pumps. The perfusion in these microfluidic systems enables the simulation of conditions of living organisms, meaning it becomes possible to mimic cell behavior which can otherwise only be observed in real organisms. Together with industrial partners and scientists of the Dresden University Hospital IWS researchers developed a multilayered Lab-on-a-Chip system for the simulation of the capillary flow condition of a kidney (pages 82/83). The system is designed to research the regeneration of a kidney, to help to understand the complicated cellular processes and to develop novel therapies.

The actuation of microfluidic systems implies various challenges. To solve these problems IWS scientists developed, together with project partners, an actuation device which operates eight micro pumps with variable pump velocities and which can heat four cell culture chambers. Quality control data can be recorded and subsequently analyzed via common interfaces. The operation of this device is user-friendly and possible via touchscreen interface.

COORDINATION

DR. UDO KLOTZBACH

phone +49 351 83391-3252
 udo.klotzbach@iws.fraunhofer.de



COORDINATION

DR. FRANK SONNTAG

phone +49 351 83391-3259
 frank.sonntag@iws.fraunhofer.de



www.iws.fraunhofer.de/biosystems

Research and developments at the Fraunhofer IWS comprise a wide range of applications:

- micro structuring as well as micro cutting and drilling with various short and ultra-short pulsed lasers
- micro laser joining
- design, simulation and generation of microfluidic structures and micro reactors as well as universal Lab-on-a-Chip platforms including actuation
- rapid prototyping of microfluidic structures and micro reactors
- generation of bio-functional / bio-compatible components (scaffolds, tissue engineering by organic printing)
- nano imprint lithography
- 2PP-Multi-Organ-Chips

IWS scientists are strongly engaged in national and international networks. Examples are networks such as Optonet, Biosaxony and EPIC.



DORTMUNDER OBERFLÄCHENCENTRUM (DOC®)

Surface technology is key to many steel products. ThyssenKrupp Steel Europe AG (TKSE) has concentrated its surface technology research and development efforts in Dortmund. The "Dortmunder OberflächenCentrum" (DOC® for Surface Technology Center Dortmund) is a globally leading research institution addressing the development of surface technologies for steel products. The DOC® develops tailored coatings, which are deposited in a continuous manufacturing process onto moving steel band substrates. Customer oriented development goals are the implementation of novel surface concepts leading to superior properties such as improved corrosion resistance, scratch resistance, electrical conductivity, forming capability or cleaning properties. Flat steel products with completely new functional properties and novel light-weight materials (LITECOR®) and thus increased value are also part of the current research, which for example includes work on solar thermal and photovoltaic properties.

The Fraunhofer IWS cooperates directly with DOC® by supporting a project group on site. This group works primarily on surface coatings using PVD, PACVD and spraying processes and on laser materials processing.



COORDINATION

DR. AXEL ZWICK

Fraunhofer IWS
phone +49 231 844 3512
axel.zwick@iws.fraunhofer.de



FRAUNHOFER-PROJECT GROUP AT DORTMUNDER OBERFLÄCHENCENTRUM DOC®

Eberhardstraße 12
44145 Dortmund

www.iws.fraunhofer.de/en/dortmund

Current main foci in the thin film technology:

- development of conducting, formable carbon layer systems,
- GLC: graphite like carbon and plasma nitro-carburized surfaces for electro mobility applications, e.g., steel bipolar sheets for fuel cells and Al/CU electrodes for batteries and super caps (pages 92/93),
- Diamor® coating systems (ta-C: tetrahedral amorphous carbon) for wear protection based on a short pulsed arc process (spArc®) for example series implementation of self-sharpening kitchen knives,
- novel PVD procedures for metal band coating processes and developments of corrosion protection properties. They base on zinc alloy coatings, e.g. for highly corrosion-resistant metallic coatings (ZnMg) and for metallic coatings in hot forming processes (ZnFe).



Laser materials processing and spray coating projects include:

- developments of joining procedures based on laser MSG hybrid welding for the lightweight construction e.g., welding of mobile crane booms made from high strength fine-grained steel (successful laser welding implementation of longitudinal seam welds of telescoping boom sections (pages 36/37),
- high speed laser welding with high beam quality solid-state lasers and low melt particle emission,
- wire arc spraying,
- combination process of joining and wire arc spraying, e.g. for the post galvanizing of weld seams,
- development of prototype welding processes with solid-state laser.

The Fraunhofer project group offers a selection of complementary surface refinement technologies, which is available at its 1100 m² laboratory space. The latest system technology is used to make spray coatings with the cost effective wire arc process, which can also be performed in an oxygen-free environment (vacuum chamber) and in combination with solid-state lasers. Surface areas of parts and tools exposed to high wear conditions can be clad with millimeter thick wear protective coatings using laser buildup welding. Even in vacuum it is possible to coat meter-sized and ton-heavy parts with nano- and micrometer thin high performance coatings including Diamor[®] films that are deposited with the cost effective and robust spArc[®] process. These coatings have an exceptional hardness and excellent low friction properties. They are deposited at high rates and at temperatures below 150 °C. New coating material systems are under development to provide additional corrosion protection properties.

The spectrum of system technology available at the Fraunhofer DOC[®] project group includes:

- modular spArc[®] evaporator technology with industrial PVD large chamber system with a usable diameter and height of 1.2 m each (batch load up to 2 tons),
- in-house developed high performance PVD technology for the metal band coating under rough vacuum conditions,
- latest wire arc spray technology with spraying cabin, vacuum chamber and the possibility to support the process with laser power,
- 3D capable laser and laser-MSG hybrid welding system (gantry portal system, robot systems) with mobile 8 kW fiber laser.

Additional systems from Fraunhofer IST and TKSE are available for joint projects. TKSE, IST and IWS jointly operate the DOC[®]'s modular and 80 m long sheet metal band coating pilot machine. The team offers research and development on vacuum coating processes for the continuous surface refinement of thin metal sheets.

The broad selection of offered processes and systems can also be efficiently combined in many instances. In combination with Fraunhofer IWS know-how we ensure that we provide TKSE, TKSE's customers and other industrial customers with technically and economically optimized solutions. New, compact and mobile solid-state lasers offer the possibility to perform process development as well as trouble shooting directly onsite and on short notice for our industrial customers.

PROJECT CENTER LASER INTEGRATED MANUFACTURING IN WROCLAW (PCW)

The scientists of the Fraunhofer Project Center Laser Integrated Manufacturing in Wrocław (founded in 2008) concentrate their research work on three major areas:

- contract work and industrial developments for customers,
- publically funded research projects within the framework of national, bilateral and European R&D programs,
- programs to strengthen the competencies of both partners.

The expertise of the Fraunhofer Project Center is based on the core competencies of the laser based IWS business units:

- ablation and cutting
- joining (welding)
- thermal coating technology
- surface technology

and on the basic areas of the CAMT (Center for Advanced Manufacturing Technologies of the Wrocław University of Technology):

- manufacturing technologies, including generative technologies
- production management
- production automation and control
- quality control systems

The Fraunhofer Project Center is located in the Institute of Production Engineering and Automation at the Wrocław University of Technology.

In 2014 the center intensified its efforts to establish the Fraunhofer model into the Polish research market, successfully advancing their close customer relations. One example is the implementation of several coating units for large area laser powder cladding processes. The units include beam shaping optics and the IWS developed powder nozzle Coax13.

EXECUTIVE DIRECTOR OF INSTITUTE

PROF. EDWARD CHLEBUS

TU Wrocław

phone +48 71 320 2705

edward.chlebus@pwr.wroc.pl



PROJECT CENTER LASER

INTEGRATED MANUFACTURING

Wrocław University of Technology

ul. Łukasiewicza 5

50-371 Wrocław, Poland

COORDINATION

DR. JAN HAUPTMANN

Fraunhofer IWS

phone +49 351 83391-3236

jan.hauptmann@iws.fraunhofer.de



www.iws.fraunhofer.de/poland

They are combined with two 5 kW fiber lasers for customers' production.

Furthermore an offline programming system for a robot-based coating system has been installed at the Technische Universität Wrocław. The offline programming system DCAM is a universally employable software system for offline programming tasks of CNC and robot systems. Processing routines and process parameters are designed, in particular for such procedures as buildup welding, hardening, cutting and welding. These routines and parameters facilitate the operator's preparation tasks.

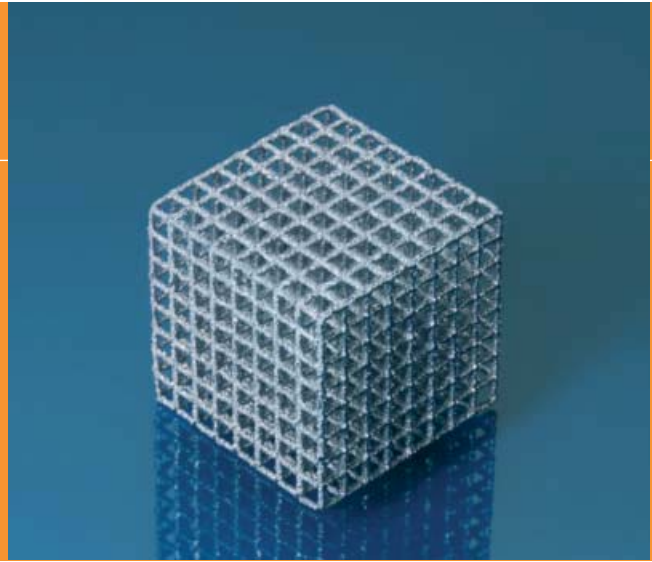
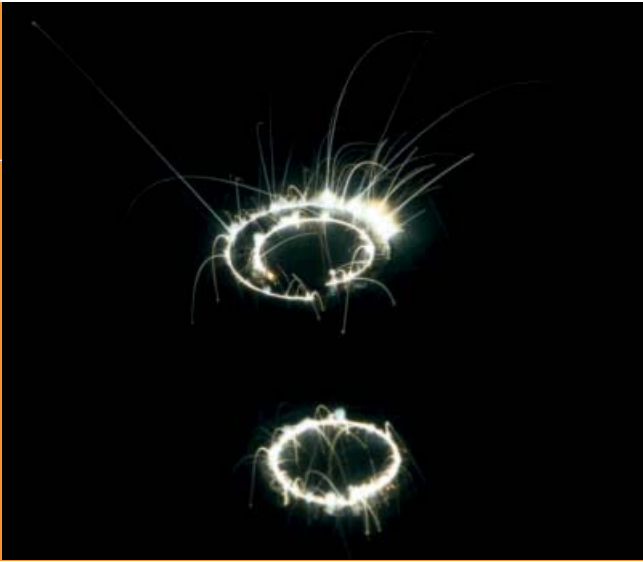

The process is as follows: 1. CAD data and scanning data of the geometry to be machined are imported. 2. The parts to be machined are prepared (determination of edges, contour lines design, surface modification). 3. The appropriate module for tool path calculation is activated and the simulation for the calculation of all axes is performed. 4. The postprocessor creates the specific CNC or robot programs.

In addition, the scientists were successful in acquiring new customers. One exciting task, for example, is the research for a partial decoating of thermal insulating coatings on architectural glass. Different laser system alternatives are tested with regard to their usability for the decoating process. Apart from high-performance cw-lasers various pulsed laser systems were applied. In all cases the wavelength was in the near infrared range, as glass, in this range, shows only a small adsorption and damages are avoided.

The test results showed that short-pulsed, high-repetition laser systems with near infrared wavelengths combined with scanning coupling can be recommended. Coating systems with additional corrosion protection are being developed.

A Polish company applies the IWS developed remote laser welding technology in its production. A comprehensive operator's instruction and training was performed on-site.

The instruction comprised the training for new operators and programs. Within the training newly developed functions were introduced and customer's requirements regarding devices and software were discussed.

The system for the joining of plate heat exchangers is equipped with an x-y galvanometer scanning device for highly dynamic laser beam motion.

A software solution, which was jointly developed by IWS scientists and engineers from the Technische Universität Wrocław, handles the activation of the scanner, the communication to the higher-level CNC control and the control of the quick signals to the laser source.

An offline programming system, also developed at the IWS, manages the programming of the welding contour, the motion distribution between system and scanner as well as the determination and optimization of the welding sequence.

The cooperation between the scientists of the two institutes was intensified with the exchange of personnel. Individualized contacts will strengthen the close partnership, one example being Dr. Karel Kozak's appointment as Honorary Professor for Information Technology. His particular expertise in the field of information technology and data processing will advance the scientific exchange between the two institutes.



FRAUNHOFER-CENTER FOR COATINGS AND LASER APPLICATIONS (CCL)

The Fraunhofer USA subsidiary is 100 % owned by the Fraunhofer-Gesellschaft. The goals of doing business in the USA are the transfer of technology, the expansion of scientific competence through intensive collaborations with research centers of outstanding international reputation and the qualification and education of employees in an international context. The President of the Fraunhofer-Gesellschaft, Prof. Reimund Neugebauer, hosted the 20th anniversary celebration of Fraunhofer USA in Boston, Massachusetts, on September 30th 2014 and also introduced a new management team of the US subsidiary. Fraunhofer USA's new President is Frank Treppe (Fig. 1, right). Mr. Treppe simultaneously serves as Head of Department for Corporate Strategy and International Affairs at the Fraunhofer-Gesellschaft. Fraunhofer USA's new Executive Vice President is Dr. Patrick Bressler (Fig. 1 left).

The US market is one of the most important innovation drivers for applied research. Therefore the IWS has for more than a decade focused on developing its daughter organization in the United States, the Center for Coatings and Laser Applications (CCL). Today the Center is successfully established in the US research market. In 2014 the Center with 21 employees and 23 students performed projects worth \$5.5 million of which \$3.2 million were contracted directly from industry.

It is very desirable to IWS to continue the growth of the Center, which requires a restructuring. Beginning in January 2015 the two CCL divisions will become centers in their own right. CCL's laser division is merging with the Center for Laser Technology to form the new Center for Laser Applications (CLA). The former CCL division director Mr. Craig Bratt will head the CLA, which continues to

CENTER DIRECTOR

PROF. JES ASMUSSEN

phone +48 71 320 2705

jasmussen@fraunhofer.org



DIRECTOR

COATING TECHNOLOGY DIVISION

DR. THOMAS SCHÜLKE

phone +1 517 432 8173

tschuelke@fraunhofer.org

East Lansing, Michigan 48824-1226, USA

www.ccd.fraunhofer.org



DIRECTOR

LASER APPLICATIONS DIVISION

CRAIG BRATT

phone +1 734 738 0550

cbratt@fraunhofer.org

Plymouth, Michigan 48170-6080, USA

www.cla.fraunhofer.org



be located in Plymouth, Michigan. The CCL division associated with Michigan State University will become the Center for Coatings and Diamond Technologies (CCD) led by Dr. Thomas Schuelke.

The long-term Fraunhofer CCL director Prof. Dr. Jes Asmussen (Fig. 3, second from right) stepped down and was honored for his service during a celebration event held on December 5th 2014. In the future he will work on selected scientific questions in the field of diamond synthesis for CCD.

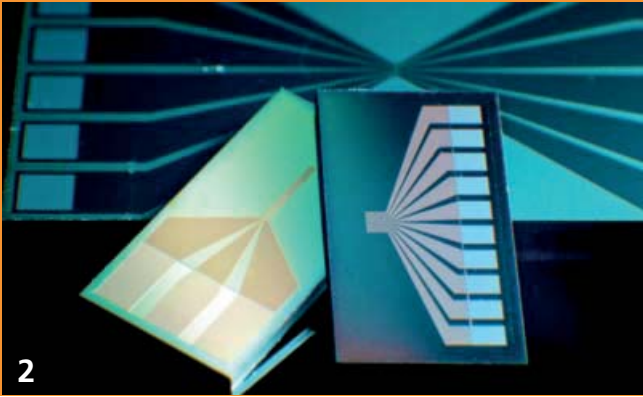

2

Coating Technology Division

CCL scientists have developed reliable manufacturing processes to produce customized boron doped diamond electrodes (Fig. 2). This new electrode material for electrochemical applications exceeds the performance of metal-based electrodes. They are also substantially less costly than platinum electrodes.

CCL engineers are working jointly with Fraunhofer IWS and a leading supplier of powertrain and braking systems on new high performance ceramic coatings for forming tools in high temperature applications. The coating process is physical vapor deposition. The coated tools are applied in forging processes of steel components at temperatures as high as 1065 °C. Compared to uncoated tools, the coated punches lasted three times as long before they had to be replaced. This is an exceptional result.

At the "Netzwerk Symposium" of the Fraunhofer-Gesellschaft, IWS and CCL scientists received a "Fraunhofer Elevator Pitch Award". The project team "QuelleSmart – Mobile Drinking Water Safety" was selected for support. The jury was convinced by the concept, which combines CCL knowhow of boron doped diamond electrodes and IWS developed detectors for heavy metal analytics in water.



3

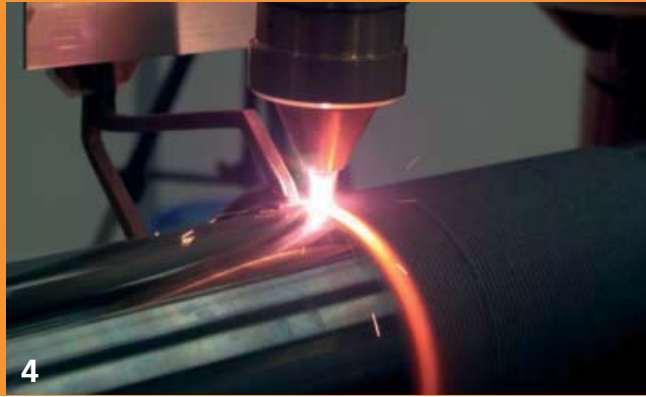

4

Laser Applications Division

CCL's laser applications division offers contract research and development services to its customers in North America in the field of high power laser applications. Applications are in the fields of laser welding, heat treatments, coating and additive manufacturing. The Plymouth site is equipped with the most modern power lasers, CNC systems and robots.

In 2014 the division installed a new CNC laser-processing machine, which includes dual core fiber technology. The system offers high precision laser processes at extremely high speeds. The work cell has a comfortable working range of 4 m x 1.5 m. The new dual core fiber technology simplifies changes between different applications and reduces down time. Applications are high-speed laser cutting, laser welding and additive manufacturing.

Customers from industry perceive the laser applications division as a "First Stop" development site for laser applications in North America. About 90 percent of the revenues are sourced from industry. The center focuses on the development of laser technologies for applications in the oil and gas industry (Fig. 4), alternative energy production, and automotive and aerospace industries.

The Center in Plymouth closely collaborates with a large number of automotive companies to develop and advance new laser technologies and applications for modern light-weight vehicle constructions and electro vehicles. Lithium-ion battery technology has become a competence at CCL. Several large industry customers in the field of battery technologies are meanwhile using CCL's laser welding technology in production.

NETWORKS

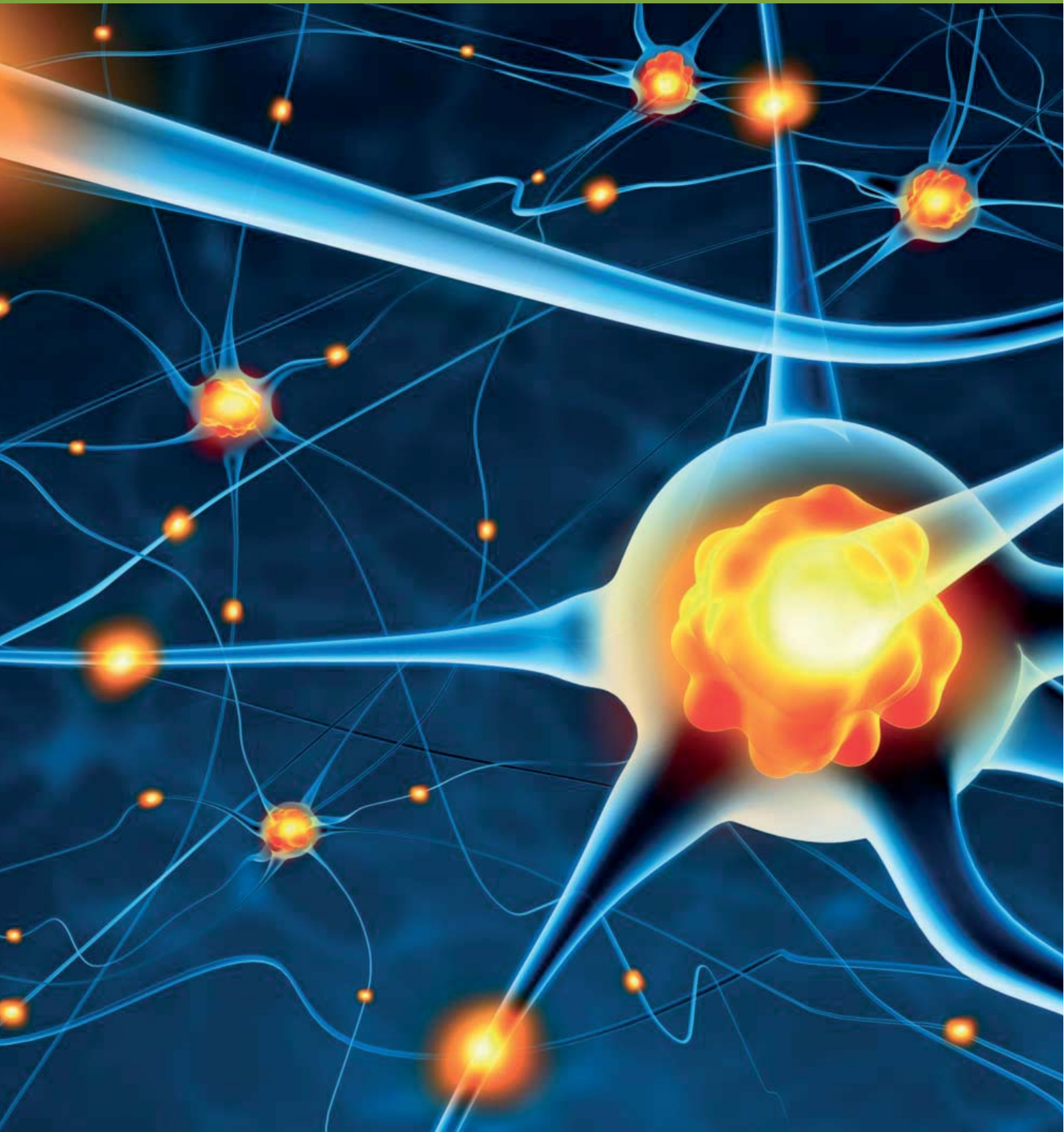

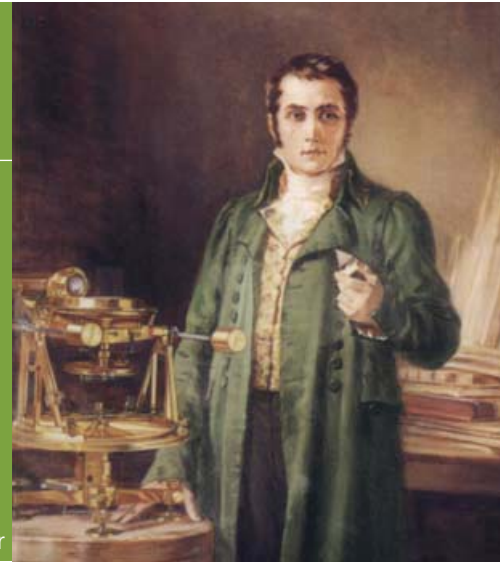

Joseph von Fraunhofer

THE FRAUNHOFER-GESELLSCHAFT

Research of practical utility lies at the heart of all activities pursued by the Fraunhofer-Gesellschaft. Founded in 1949, the research organization undertakes applied research that drives economic development and serves the wider benefit of society. Its services are solicited by customers and contractual partners in industry, the service sector and public administration.

At present, the Fraunhofer-Gesellschaft maintains 66 institutes and research units. The majority of the more than 24,000 staff are qualified scientists and engineers, who work with an annual research budget of 2 billion euros. Of this sum, more than 1.7 billion euros is generated through contract research. More than 70 percent of the Fraunhofer-Gesellschaft's contract research revenue is derived from contracts with industry and from publicly financed research projects. Almost 30 percent is contributed by the German federal and Länder governments in the form of base funding, enabling the institutes to work ahead on solutions to problems that will not become acutely relevant to industry and society until five or ten years from now.

International collaborations with excellent research partners and innovative companies around the world ensure direct access to regions of the greatest importance to present and future scientific progress and economic development.

With its clearly defined mission of application-oriented research and its focus on key technologies of relevance to the future, the Fraunhofer-Gesellschaft plays a prominent role in the German and European innovation process. Applied research has a knock-on effect that extends beyond the direct benefits perceived by the customer: Through their research and development work, the Fraunhofer Institutes help to reinforce the competitive strength of the economy in their local region, and throughout Germany and Europe. They

do so by promoting innovation, strengthening the technological base, improving the acceptance of new technologies, and helping to train the urgently needed future generation of scientists and engineers.

As an employer, the Fraunhofer-Gesellschaft offers its staff the opportunity to develop the professional and personal skills that will allow them to take up positions of responsibility within their institute, at universities, in industry and in society. Students who choose to work on projects at the Fraunhofer Institutes have excellent prospects of starting and developing a career in industry by virtue of the practical training and experience they have acquired.

The Fraunhofer-Gesellschaft is a recognized non-profit organization that takes its name from Joseph von Fraunhofer (1787–1826), the illustrious Munich researcher, inventor and entrepreneur.

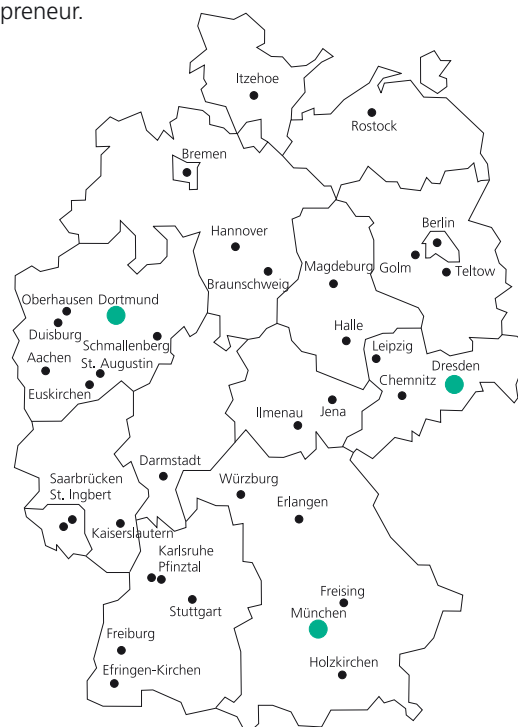

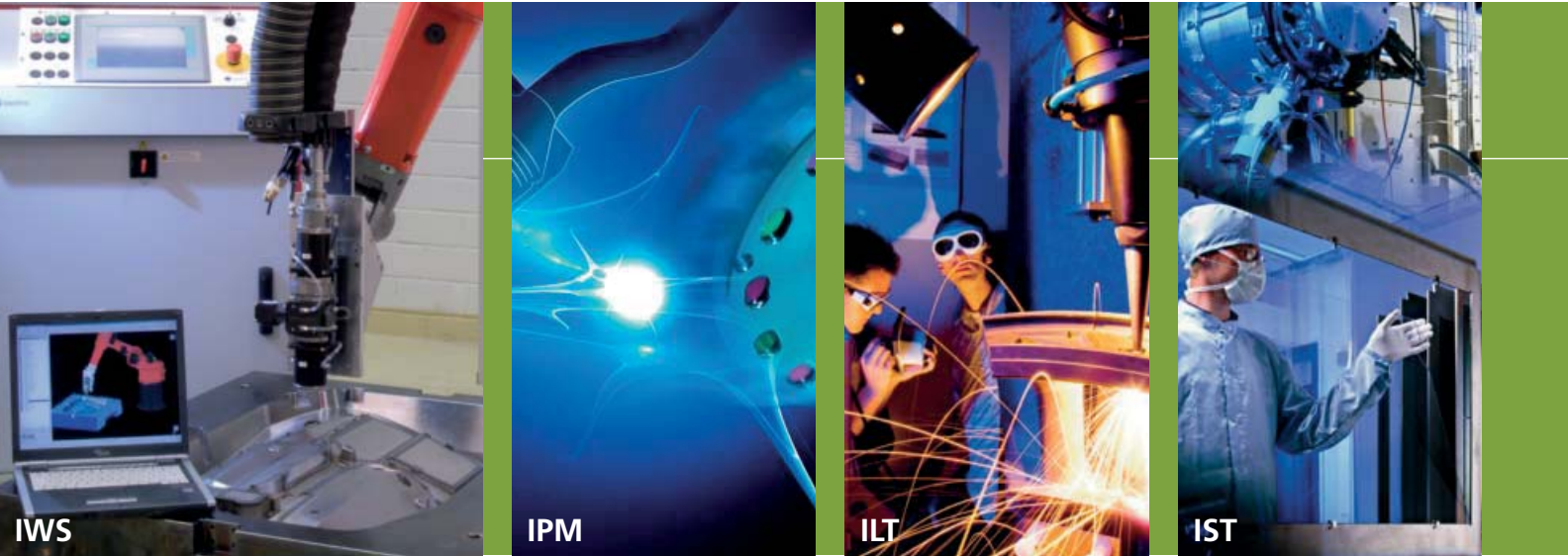

FRAUNHOFER-GROUP LIGHT & SURFACES

COMPETENCE BY NETWORKING

Six Fraunhofer institutes cooperate in the Fraunhofer Group Light & Surfaces. Co-ordinated competences allow quick and flexible alignment of research work on the requirements of different fields of application to answer actual and future challenges, especially in the fields of energy, environment, production, information and security. This market-oriented approach ensures an even wider range of services and creates synergetic effects for the benefit of our customers.

CORE COMPETENCES OF THE GROUP

- surface and coating functionalization
- laser-based manufacturing processes
- laser development and nonlinear optics
- materials in optics and photonics
- microassembly and system integration
- micro and nano technology
- carbon technology
- measurement methods and characterization
- ultra precision engineering
- material technology
- plasma and electron beam sources

CONTACT

Group Chairman
Prof. Dr. Andreas Tünnermann

Group Assistant
Susan Oxfart
phone: +49 3641 807-207
www.light-and-surfaces.fraunhofer.de

FRAUNHOFER INSTITUTE FOR ORGANIC ELECTRONIC, ELECTRON BEAM AND PLASMA TECHNOLOGY FEP, DRESDEN

Electron beam technology, sputtering technology, plasma-activated high-rate deposition and high-rate PECVD are the core areas of expertise of Fraunhofer FEP. The business units include vacuum coating, surface modification and treatment with electrons and plasmas. Besides developing layer systems, products and technologies, another main area of work is the scale-up of technologies for coating and treatment of large areas at high productivity.

www.fep.fraunhofer.de

FRAUNHOFER INSTITUTE FOR LASER TECHNOLOGY ILT, AACHEN

Since 1985 the Fraunhofer Institute for Laser Technology ILT has developed innovative laser beam sources, laser technologies, and laser systems for its partners from the industry. Our technology areas cover the following topics: laser and optics, medical technology and biophotonics, laser measurement technology and laser materials processing. This includes laser cutting, caving, drilling, welding and soldering as well as surface treatment, micro processing and rapid manufacturing. Furthermore, the Fraunhofer ILT is engaged in laser plant technology, process control, modeling as well as in the entire system technology.

www.ilt.fraunhofer.de

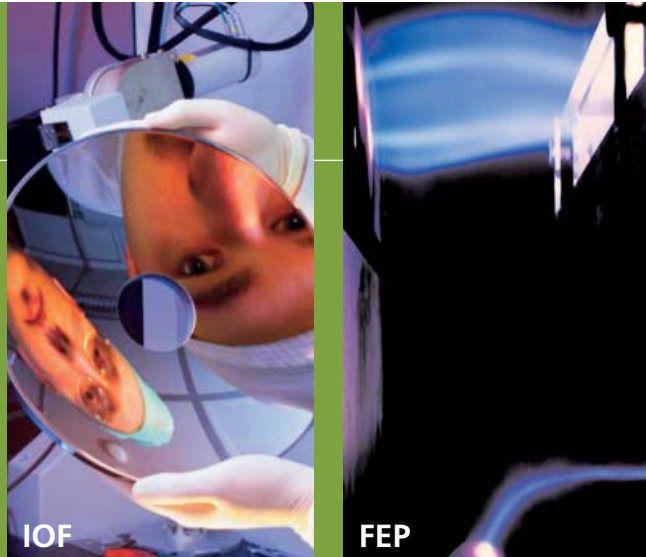

FRAUNHOFER INSTITUTE FOR APPLIED OPTICS AND PRECISION ENGINEERING IOF, JENA

The Fraunhofer IOF develops solutions with light to cope foremost challenges for the future in the areas energy and environment, information and security, as well as health care and medical technology. The competences comprise the entire process chain starting with optics and mechanics design via the development of manufacturing processes for optical and mechanical components and processes of system integration up to the manufacturing of prototypes. Focus of research is put on multifunctional optical coatings, micro- and nano-optics, solid state light sources, optical measurement systems, and opto-mechanical precision systems.

www.iof.fraunhofer.de

FRAUNHOFER INSTITUTE FOR PHYSICAL MEASUREMENT TECHNIQUES IPM, FREIBURG

Fraunhofer IPM develops and builds optical sensor and imaging systems. These mostly laser-based systems combine optical, mechanical, electronic and software components to create perfect solutions of robust design that are individually tailored to suit the conditions at the site of deployment. In the field of thermoelectrics, the institute has extensive know-how in materials research, simulation, and systems. Fraunhofer IPM also specializes in thin-film technologies for application in the production of materials, manufacturing processes and systems.

www.ipm.fraunhofer.de

FRAUNHOFER INSTITUTE FOR SURFACE ENGINEERING AND THIN FILMS IST, BRAUNSCHWEIG

As an industry oriented R&D service center, the Fraunhofer IST is pooling competencies in the areas film deposition, coating application, film characterization, and surface analysis. Scientists, engineers, and technicians are busily working to provide various types of surfaces with new or improved functions and, as a result, help create innovative marketable products. The institute's business segments are: mechanical and automotive engineering, aerospace, tools, energy, glass and facade, optics, information and communication, life science and ecology.

www.ist.fraunhofer.de

FRAUNHOFER INSTITUTE FOR MATERIAL AND BEAM TECHNOLOGY IWS, DRESDEN

The Fraunhofer Institute for Material and Beam Technology is known for its innovations in the business areas joining and cutting as well as in the surface and coating technology. Our special feature is the expertise of our scientists in combining the profound know-how in materials engineering with the extensive experience in developing system technologies. Every year, numerous solution systems have been developed and have found their way into industrial applications.

www.iws.fraunhofer.de



EXCELLENT COOPERATION PARTNER TU DRESDEN

The cooperation with the TU Dresden began in 1997. Since then the Fraunhofer IWS has continuously expanded the cooperation with various university chairs. Such collaboration enables the combination of the broad basic science knowledge of the university with the applied development work performed at the IWS. Professors and coworkers at the TU Dresden are closely involved in IWS research projects and have access to the technical equipment and infrastructure at the institute. IWS management and coworkers support the university in educating students and graduate students. Junior scientists emerge from this pool. This effort is driven by these scientists:

FACULTY OF MECHANICAL SCIENCE AND ENGINEERING INSTITUTE OF MANUFACTURING TECHNOLOGY

**CHAIR OF LASER AND SURFACE
TECHNOLOGY**
**PROF. DR.-ING. HABIL. DR. H. C.
ECKHARD BEYER**



Topics:

- laser systems technology
- laser machining processes
- plasma in manufacturing
- surface technologies
- laser robotics

FACULTY OF MATHEMATICS AND NATURAL SCIENCES DEPARTMENT OF CHEMISTRY AND FOOD CHEMISTRY

CHAIR OF INORGANIC CHEMISTRY
**PROF. DR. RER. NAT. HABIL.
STEFAN KASKEL**



Topics:

- synthesis, characterization and application of porous materials
- inorganic nanoparticles
- nanocomposites and hybrid materials

FACULTY OF MECHANICAL SCIENCE AND ENGINEERING INSTITUTE OF MATERIALS SCIENCE

CHAIR OF MATERIALS SCIENCE
**PROF. DR.-ING.
CHRISTOPH LEYENS**



Topics:

- metallic and intermetallic high temperature materials
- ferrous and nonferrous materials
- surface and coating technologies
- relationships between microstructure and properties of metallic materials



"Science needs cooperation meaning the knowledge of the one is enriched by another's discovery."

José Ortega y Gasset

**FACULTY OF MECHANICAL SCIENCE AND ENGINEERING
INSTITUTE OF MANUFACTURING TECHNOLOGY**

**CHAIR OF LASER AREA BASED
MICRO/NANO STRUCTURING
PROF. DR.-ING.
ANDRÉS-FABIÁN LASAGNI**



Topics:

- fabrication of large area 2- and 3D micro and nanostructures
- surface functionalization
- laser structuring
- two photon polymerization
- simulation of structuring processes
- process development

**FACULTY OF MECHANICAL SCIENCE AND ENGINEERING
INSTITUTE OF MATERIALS SCIENCE**

**CHAIR OF MATERIALS TESTING AND
CHARACTERIZATION
PROF. DR.-ING.
MARTINA ZIMMERMANN**



Topics:

- mechanical properties and microstructure
- fatigue (high frequency test engineering)
- failure analysis and prevention
- structure and component reliability

**FACULTY OF MECHANICAL SCIENCE AND ENGINEERING
INSTITUTE OF MANUFACTURING TECHNOLOGY**

**CHAIR OF NANO- AND COATING
TECHNOLOGY
PROF. DR. RER. NAT.
ANDREAS LESON**



Topics:

- nanotechnology
- thin film technology

**FACULTY OF MECHANICAL SCIENCE AND ENGINEERING
INSTITUTE OF MANUFACTURING TECHNOLOGY**

**CHAIR OF PRODUCTION TECHNOLOGY
STEINBEIS UNIVERSITY
PROF. DR.-ING.
ULRICH GÜNTHER**



Topics:

- surface cutting
- production design



SPECIAL EVENTS

FEBRUARY 27th - 28th 2014

8th International Laser Symposium "Fiber, Disc, Diode & 2nd International Symposium "Tailored Joining" at the International Congress Center Dresden
(organizer: Fraunhofer IWS Dresden)

MARCH 26th - 27th 2014

TAW Symposium "Thermal Coating with Laser Based Manufacturing Processes", Technical Academy Wuppertal e.V. in collaboration with the Fraunhofer IWS Dresden and the FriBa Lasernet Holzkirchen in Dresden

MARCH 27th 2014

Fraunhofer IWS Dresden participates in federal "Girls Day" activities

MARCH 31st 2015

Completion of the third construction expansion of the Fraunhofer IWS Dresden for activities in the field of nanotechnology

JULY 1st - 3rd 2014

10th International Nanotechnology Symposium "New ideas for industry" together with the 2nd Dresden Nanoanalysis Symposium at the International Congress Center Dresden (organizer: Fraunhofer IWS Dresden, Dresden Center for Nanoanalysis (DCN), the City of Dresden)

JULY 4th 2014

Fraunhofer Institutes Center Dresden participates in the "Long Night of the Sciences" of the state capital Dresden

AUGUST 18th - 22nd 2014

Scientific Campus of the Fraunhofer-Gesellschaft in Dresden
(organizer: Fraunhofer-Zentrale)

AUGUST 25th - 29th 2014

3rd International Summer School "Trends and New Developments in Laser Technology"
(organizer: Fraunhofer IWS Dresden)

NOVEMBER 11th 2014

Colloquium "Material-Optimized Laser Technologies" on the occasion of the 65th anniversary of Prof. Dr. Berndt Brenner
(organizer: Fraunhofer IWS Dresden)

NOVEMBER 12th - 13th 2014

3rd Workshop "Lithium-Sulfur Batteries" at the Fraunhofer IWS Dresden (organizer: Fraunhofer IWS Dresden and Institut für Anorganische Chemie der TU Dresden)

NOVEMBER 27th 2014

Workshop "Ultra-Barrier Manufacturing and Testing" at the Fraunhofer IWS Dresden (organizer: Fraunhofer IWS and FEP Dresden, Organic Electronics Saxony e.V.)

NOVEMBER 27th 2014

Completion of the fourth construction expansion of the Fraunhofer IWS and setting up of the Center for Resource-Saving Energy Technologies RESET

AWARDS AND HONORS



The German Society for Materials Science (DGM), the German Association for Materials Research and Testing (DVM) and The Steel Institute VDEh jointly awarded **Prof. Dr. Martina Zimmermann** with the Galileo Prize for her outstanding achievements and contributions in the field of materials testing research.

Martina Zimmermann successfully concentrated her research into the experimental challenges and theoretical background concerning the topic Very High Cycle Fatigue (VHCF). Through her active engagement she was able to decisively contribute to a broad understanding of the fatigue behavior of structural metal materials at very high cycle rates and succeeded in stimulating comprehensive national and international research activities.



Prof. Andreas Leson, Deputy Director of the Fraunhofer IWS, was honored for his extraordinary dedication in the field of Thin Films at the 11th Symposium of European Vacuum Coaters in Anzio (Italy) on September 28, 2014. The award "A life for thin film" particularly honors experts in the field of film and surface technology, who have dedicated their careers to interaction between research, life and art.

Dr. Wulf Grählert, Dr. Harald Beese and Prof. Dr. Stefan Kaskel together with Johannes Grübler, Jörg Koch, from Sempa Systems were honored with the Hans Pulkner Award at the 10th International Conference on Coatings on Glass and Plastics ICCG in Dresden for their poster, titled "New concepts for the reliable testing of the water vapor transmission rate of ultra-high barrier coatings in the range of 10^{-4} to 10^{-6} g m⁻² d⁻¹".

The first prize went to the poster "Novel corrosion-protection systems for sheet components", presented at the BMBF-Forum MatRessource " Die Förderinitiative des BMBF zu Materialien im Kontext von Ressourcen, Recycling, Substitution, Katalyse und Korrosionsschutz" in Darmstadt in September 2014. **Dr. Axel Zwick, Dr. Thomas Stucky and Dr. Slavcho Topalski** from the Fraunhofer IWS received the award together with ThyssenKrupp Steel Europe and Daimler scientists .

On December 17, 2014 IWS prize winners received their awards

Andreas Grimm, Sebastian Schulze, René Eger and Robert Plach received an award honoring their outstanding scientific and technical performance for their development of novel joining technologies for future metal fuselage structures. They developed flexible fixtures, which are attached and aligned to the fuselage shell via vacuum pads. An electrically driven guide carriage moves a spindle on a three-dimensional rail system for edge trimming and component friction stir welding. The direct coupling of shell, guidance, guide carriage and tool eradicates the need for classical welding systems and clamping devices. The team demonstrated that the system (called MUVAX) enables the efficient fabrication of metal fuselage structures implying significant weight reduction and lower manufacturing costs (pages 30/31).



The award for the innovative product idea to launch a new business field went to **Jens Liebscher**. He focused his research into possibilities to transfer the double-sided laser welding technology to components of the railroad vehicle industry. With the help of this technology, initially developed for aviation applications, it became possible to weld complete sidewall structures. A flexible, cost-saving clamping device enabled the almost gap-free joining of the stiffener elements and the outer panel. This technology operates without additional welding wires, reduces weight, distortion and manufacturing costs (pages 28/29).

Dr. Elena López received one of the two awards for the best performance of a young scientist. In her doctoral thesis she researched in the field of dry chemical plasma etching of solar wafers with atmospheric pressure plasmas. The chemical plasma etching process was successfully applied for the edge isolation of wafers. The patented procedure is characterized by high flexibility, high efficiency and optimum light injection in solar cells.

Erik Pflug was also honored with the award for the best performance of a young scientist. He developed a technology to join polymers, CFK, GFK and hybrid metal joints via reactive multilayer systems (RMS). The system's energy is adjusted to the joining application via the stoichiometric ratio of nickel and aluminum or via the period thickness of the layer staple. Thermoplastics or glass fiber reinforced polyamide and carbon reinforced polyetherimide can be joined via RMS within seconds without any pre-treatment.

Markus Mielke was recognized as an outstanding student performer for his research on "Using Al-Si solders for joining procedures via reactive multilayer systems". The combined use of RMSs and Al-Si solder enabled hard soldering procedures of diversified material combinations, substituting the expensive silver-based hard solder (pages 102/103).

Furthermore **Florian Gruber** was also recognized for his outstanding student performance. Florian Gruber characterized different large-area OLED layers with respect to their lateral film thickness and to contaminations via hyperspectral imaging (HSI).

Another prize went to **Nick Kulissa** for his automated feed system for nanoparticle-containing suspensions for thermal spray processes (pages 50/51). The modular setup for suspension spraying operates via three different vessels and is a highly economic and an attractive IWS solution.

A special prize of the institute went to **Kerstin Zenner** and **René Zenner** for their extraordinary process animations and presentations.



Florian Gruber, Eckhard Beyer, René Zenner, Anja Techel, Kerstin Zenner, Andreas Leson, Sebastian Schulze, Andreas Grimm, Robert Plach, Jens Liebscher, Elena López, Markus Mielke, René Eger, Erik Pflug (f.l.t.r.)

PUBLICATIONS

[L1]

Asafa, T.B.; Witvrouw, A.; Schneider, D.; Moussa, A.; Tabet, N.; Said, S.A.M.:

»Thickness effect on the structural and electrical properties of poly-SiGe films.«

Materials research bulletin 49 (2014), Nr.1, S.102-107
DOI: 10.1016/j.materresbull.2013.08.054

[L2]

Barbosa, M.M.; Puschmann, R.; Thiele, S.; Toma, F.-L.; Martin, H.P.; Berger, L.-M.; Leyens, C.; Beyer, E.; Laag, N.J. van der:

»Development of thermally sprayed $\text{Ca}_2\text{Fe}_2\text{O}_5$ coatings for thermoelectrical applications.«

Deutscher Verband für Schweißen und Verwandte Verfahren e. V. -DVS-; The Thermal Spray Society - TSS-; International Institute of Welding -IIW-: ITSC 2014, International Thermal Spray Conference & Exposition: Abstracts (including manuscripts on CD-ROM) of the conference in Barcelona, Spain, on May 21-23, 2014
Düsseldorf: DVS Media, 2014, S.485-490
(DVS-Berichte 302)

[L3]

Bauer, I.; Thieme, S.; Brückner, J.; Althues, H.; Kaskel, S.:

»Reduced polysulfide shuttle in lithium-sulfur batteries using Nafion-based separators.«

Journal of power sources 251 (2014), S.417-422
DOI: 10.1016/j.jpowsour.2013.11.090

[L4]

Bauer, I.; Kohl, M.; Althues, H.; Kaskel, S.:

»Shuttle suppression in room temperature sodium-sulfur batteries using ion selective polymer membranes.«

Chemical communications 50 (2014), Nr.24, S.3208-3210
DOI: 10.1039/c4cc00161c

[L5]

Bellmann, J.; Wagner, M.; Jahn, A.; Brenner, B.; Kröger, M.:

»Stahl-Aluminium-Mischverbindungen für belastungsgerechten Werkstoffeinsatz.«

Lightweight design (2014), Nr.6, S.30-35

[L6]

Berger, L.-M.; Shakhverdova, I.; Puschmann, R.; Gräfensteiner, D.M.; Leidich, E.; Schiefer, S.; Gerlach, M.:

»Investigation of HVOF-sprayed (Ti,Mo)(C,N)-Ni hardmetal coatings for static friction applications.«

Deutscher Verband für Schweißen und Verwandte Verfahren e. V. -DVS-; The Thermal Spray Society - TSS-; International Institute of Welding -IIW-: ITSC 2014, International Thermal Spray Conference & Exposition: Abstracts (including manuscripts on CD-ROM) of the conference in Barcelona, Spain, on May 21-23, 2014
Düsseldorf: DVS Media, 2014, S.239-245
(DVS-Berichte 302)

[L7]

Berger, L.-M.; Toma, F.-L.; Scheitz, S.; Trache, R.; Börner, T.:

»Thermisch gespritzte Schichten im System Al_2O_3 - Cr_2O_3 - TiO_2 - ein Update.«

Materialwissenschaft und Werkstofftechnik 45 (2014), Nr.6, S.465-475
DOI: 10.1002/mawe.201400260

[L8]

Berger, L.-M.:

»Application of hardmetals as thermal spray coatings.«

International journal of refractory metals and hard materials (2014), Online First, 15 S.
DOI: 10.1016/j.ijrmhm.2014.09.029

[L9]

Berger, L.-M.; Thiele, S.; Börner, T.; Janka, L.C.; Rodriguez R.M.:

»Influence of Cr_3C_2 -NiCr feedstock powder characteristics on the deposition efficiency, coating microstructures and abrasion wear resistance.«

Deutscher Verband für Schweißen und Verwandte Verfahren e. V. -DVS-; The Thermal Spray Society - TSS-; International Institute of Welding -IIW-: ITSC 2014, International Thermal Spray Conference & Exposition: Abstracts (including manuscripts on CD-ROM) of the conference in Barcelona, Spain, on May 21-23, 2014
Düsseldorf: DVS Media, 2014, S.806-812
(DVS-Berichte 302)

[L10]

Biemelt, T.; Selzer, C.; Schmidt, F.; Mondin, G.; Seifert, A.; Pinkert, K.; Spange, S.; Gemming, T.; Kaskel, S.:

»Hierarchical porous zeolite ZSM-58 derived by desilication and desilication re-assembly.«

Microporous and mesoporous materials 187 (2014), S.114-124
DOI: 10.1016/j.micromeso.2013.12.028

[L11]

Boelli, G.; Berger, L.-M.; Bonetti, M.; Lusvardi, L.:

»Comparative study of the dry sliding wear behaviour of HVOF-sprayed WC-(W,Cr)₂C-Ni and WC-CoCr hardmetal coatings.«

Wear 309 (2014), Nr.1-2, S.96-111
DOI: 10.1016/j.wear.2013.11.001

[L12]

Braun, S.:

»Röntgenlinsen für die Nanoanalytik.«

Laser-Magazin (2014), Nr.3, S.60-61

[L13]

Braun, S.; Gawlitza, P.; Menzel, M.; Friedrich, W.; Schmidt, J.; Leson, A.:

»Specific aspects of roughness and interface diffusion in non-periodic MoSi multilayers.«

Morawe, C. ; Society of Photo-Optical Instrumentation Engineers - SPIE-, Bellingham/Wash.: Advances in X-Ray/EUV Optics and Components IX : 18_DS20 August 2014, San Diego, California Bellingham, WA: SPIE, 2014, Paper 920707, 10 S.
(Proceedings of SPIE 9207)
DOI: 10.1117/12.2062193

- [L14]**
Brückner, J.; Thieme, S.; Böttger-Hiller, F.; Bauer, I.; Grossmann, T.; Strubel, P.; Althues, H.; Spange, S.; Kaskel, S.:
»Carbon-based anodes for lithium sulfur full cells with high cycle stability.«
Advanced Functional Materials 24 (2014), Nr.9, S.1284-1289
DOI: 10.1002/adfm.201302169
- [L15]**
Brückner, J.; Thieme, S.; Grossmann, H.T.; Dörfler, S.; Althues, H.; Kaskel, S.:
»Lithium-sulfur batteries: Influence of C-rate, amount of electrolyte and sulfur loading on cycle performance.«
Journal of power sources 268 (2014), S.82-87
DOI: 10.1016/j.jpowsour.2014.05.143
- [L16]**
Dörfler, S.; Pinkert, K.; Weiser, M.; Wabnitz, C.; Goldberg, A.; Ferse, B.; Giebeler, L.; Althues, H.; Schneider, M.; Eckert, J.; Michaelis, A.; Beyer, E.; Kaskel, S.:
»D2 enertrode: Production technologies and component integration of nanostructured carbon electrodes for energy technology - functionalized carbon materials for efficient electrical energy supply.«
Advanced engineering materials 16 (2014), Nr.10, S.1196-1201
DOI: 10.1002/adem.201400184
- [L17]**
Goppold, S.; Zanger, K.; Herwig, P.; Wetzig, A.; Mahrle, A.; Beyer, E.:
»Experimental analysis for improvements of process efficiency and cut edge quality of fusion cutting with 1 µm laser radiation.«
Schmidt, F.: Laser Assisted Net Shape Engineering 8: International Conference on Photonic Technologies, Proceedings of the LANE 2014, September 08-11, 2014, Fürth, Germany
Amsterdam: Elsevier, 2014, S.892-900
(Physics Procedia 56.2014)
DOI: 10.1016/j.phpro.2014.08.108
- [L18]**
Götze, A.; Makowski, S.; Kunze, T.; Hübner, M.; Zellbeck, H.; Weinhacht, V.; Leson, A.; Beyer, E.; Joswig, J.-O.; Seifert, G.; Abrasonis, G.; Posselt, M.; Fassbender, J.; Möller, W.; Gemming, S.; Krause, M.:
»Tetrahedral amorphous carbon coatings for friction reduction of the valve train in internal combustion engines.«
Advanced engineering materials 16 (2014), Nr.10, S.1226-1233
DOI: 10.1002/adem.201400188
- [L19]**
Grigoriev, S.N.; Tarasova, T.V.; Gvozdeva, G.O.; Nowotny, S.:
»Microcladding of hypereutectic Al-Si alloys: technological aspects and structure features.«
International journal of cast metals research 27 (2014), Nr.6, S.357-361
DOI: 10.1179/1743133614Y.0000000119
- [L20]**
Grigoriev, S.N.; Tarasova, T.V.; Gvozdeva, G.O.; Nowotny, S.:
»Solidification behaviour during laser microcladding of Al-Si alloys.«
Surface and coatings technology (2014), Online First, 7 S.
DOI: 10.1016/j.surfcoat.2014.08.001
- [L21]**
Grigoriev, S.N.; Tarasova, T.V.; Gvozdeva, G.O.; Nowotny, S.:
»Structure formation of hypereutectic Al-Si-alloys produced by laser surface treatment.«
Strojniski vestnik = Journal of mechanical engineering 60 (2014), Nr.6, S.389-394
DOI: 10.5545/sv-jme.2013.1211
- [L22]**
Grünzweig, C.; Siebert, R.; Betz, B.; Rauscher, P.; Schäfer, R.; Lehmann, E.:
»Determination of bulk magnetic volume properties by neutron dark-field imaging.«
Schneider, J.; TU Bergakademie Freiberg, Institut für Metallformung; Univ. Gent: 6th International Conference on Magnetism and Metallurgy, WMM 2014: Cardiff, UK, June 17th to 19th, 2014
Cardiff: Spectrum Printing, 2014, S.351-359
- [L23]**
Hagen, M.; Quiroga-González, E.; Dörfler, S.; Fahrner, G.; Tübke, J.; Hoffmann, M.J.; Althues, H.; Speck, R.; Krampfert, M.; Kaskel, S.; Föll, H.:
»Studies on preventing Li dendrite formation in Li-S batteries by using pre-lithiated Si microwire anodes.«
Journal of power sources 248 (2014), S.1058-1066
DOI: 10.1016/j.jpowsour.2013.09.144
- [L24]**
Heitmanek, M.; Dobler, M.; Graudenz, M.; Perret, W.; Göbel, Gunther; Schmidt, M.; Beyer, E.:
»Laser brazing with beam scanning: Experimental and simulative analysis.«
Schmidt, F.: Laser Assisted Net Shape Engineering 8 : International Conference on Photonic Technologies, Proceedings of the LANE 2014, September 08-11, 2014, Fürth, Germany
Amsterdam: Elsevier, 2014, S.689-698
(Physics Procedia 56.2014)
DOI: 10.1016/j.phpro.2014.08.076
- [L25]**
Henseleit, A.; Stürmer, J.; Pohl, C.; Hausteil, N.; Sonntag, F.; Bley, T.; Boschke, E.:
»Surface plasmon resonance based detection of human serum albumin as a marker for hepatocytes activity.«
Institute of Electrical and Electronics Engineers -IEEE-: Ninth International Conference on Intelligent Sensors, Sensor Networks and Information Processing, ISSNIP 2014 : Singapore, 21 - 24 April 2014 Piscataway, NJ: IEEE, 2014, S.80-84
DOI: 10.1109/ISSNIP.2014.6827601
- [L26]**
Kaspar, J.; Zimmermann, M.; Ostwaldt, A.; Göbel, G.; Standfuß, J.; Brenner, B.:
»Challenges in joining aluminium with copper for applications in electro mobility.«
Mishra, B.; The Minerals, Metals and Materials Society -TMS-, Warrendale/Pa.: THERMEC 2013, 8th International Conference on Processing and Manufacturing of Advanced Materials. Proceedings: December 2 - 6, 2013, Las Vegas, USA
Durnten-Zurich: Trans Tech, 2014, S.1747-1752 (Materials Science Forum 783-786)
DOI: 10.4028/www.scientific.net/MSF.783-786.1747
- [L27]**
Kaulfuß, F.; Zimmer, O.:
»Temperaturstabile Hartstoffschichten zur Standzeitverlängerung von Schmiedewerkzeugen.«
Sörgel, T.: Jahrbuch Oberflächen-technik. Bd.70
Saulgau: Leuze, 2014, S.61-70
- [L28]**
Klotzbach, U.; Sonntag, F.; Grünzner, S.; Busek, M.; Schmieder, F.; Franke, V.:
»Multilayer-based lab-on-a-chip systems for perfused cell-based assays.«
Advanced Optical Technologies 3 (2014), Nr.5-6, S.515-521
DOI: 10.1515/aot-2014-0046
- [L29]**
Köckritz, T.; Jansen, I.; Beyer, E.:
»Modifikation eines additionsvernetzten Silicons _DS Kombination verschieden modifizierter Elastomerschichten zur Herstellung eines Polymeraktors.«
TH Aachen -RWTH-, Institut für Schweißtechnik und Fügetechnik - ISF-: 3. Doktorandenseminar Klebtechnik: Vorträge der gleichnamigen Veranstaltung in Kassel am 5. und 6. November 2012
Düsseldorf: DVS Media, 2014, S.6-11
(DVS-Berichte 303)
- [L30]**
Kotte, L.; Haag, J.; Mertens, T.; Kaskel, S.:
»Atmospheric plasma deposition of SiO₂ films for adhesion promoting layers on titanium.«
Metals 4 (2014), Nr.4, S.639-646
DOI: 10.3390/met4040639

[L31]

Krätzer, L.; Lorenz, H.; Berthold, C.; Sonntag, F.

»ARM-basierte, echtzeitfähige Hardwareplattform für Datenerfassung, Signalverarbeitung und eHealth.«

Förster, A.: 5. Dresdner Medizintechnik Symposium 2014 : Biomedizinische Technik_DS Von der Grundlagenforschung zum Transfer, 01.-03.12.2014, Dresden
Stuttgart: Steinbeis-Edition, 2014, S.59-62 (Reports on Biomedical Engineering 2)
URL: <http://publica.fraunhofer.de/documents/N-321979.html>

[L32]

Kubec, A.; Braun, S.; Niese, S.; Krüger, P.; Patommel, J.; Hecker, M.; Leson, A.; Schroer, C.G.:

»Ptychography with multilayer Laue lenses.«

Journal of synchrotron radiation 21 (2014), Nr.5, S.1122-1127
DOI: 10.1107/S1600577514014556

[L33]

Lasagni, A.; Roch, T.; Bieda, M.; Benke, D.; Beyer, E.:

»High speed surface functionalization using direct laser interference patterning, towards 1 m²/min fabrication speed with sub-µm resolution.«

Klotzbach, U. ; Society of Photo-Optical Instrumentation Engineers - SPIE-, Bellingham/Wash.: Laser-based Micro- and Nanoprocessing VIII: February 2014, San Francisco, California, United States Bellingham, WA: SPIE, 2014, Paper 89680A, 9 S. (SPIE Proceedings 8968)
DOI: 10.1117/12.2041215

[L34]

Leifert, A.; Mondin, G.; Doerfler, S.; Hampel, S.; Kaskel, S.; Hofmann, E.; Zschetzsch, J.; Pflug, E.; Dietrich, G.; Rühl, M.; Braun, S.; Schädlich, S.:

»Fabrication of nanoparticle-containing films and nano layers for alloying and joining.«

Advanced engineering materials 16 (2014), Nr.10, S.1264_DS1269
DOI: 10.1002/adem.201400196

[L35]

Leson, A.:

»Neue Werkstoffe sind für die Entwicklung nachhaltiger Produkte entscheidend.«

Vakuu in Forschung und Praxis 26 (2014), Nr.3, S.38-39
DOI: 10.1002/vipr.201490022

[L36]

Linashcke, D.; Schilling, N.; Dani, I.; Klotzbach, U.; Leyens, C.:

»Highly n-doped surfaces on n-type silicon wafers by laser-chemical processes.«

Energy Procedia 55 (2014), S.247_DS254
DOI: 10.1016/j.egypro.2014.08.076

[L37]

Lode, A.; Meissner, K.; Luo, Y.; Sonntag, F.; Glorius, S.; Nies, B.; Vater, C.; Despang, F.; Hanke, T.; Gelinsky, M.:

»Fabrication of porous scaffolds by three-dimensional plotting of a pasty calcium phosphate bone cement under mild conditions.«

Journal of tissue engineering and regenerative medicine 8 (2014), Nr.9, S.682-693
DOI: 10.1002/term.1563

[L38]

Lueg-Althoff, J.; Lorenz, A.; Gies, S.; Weddeling, C.; Göbel, G.; Tekkaya, A.; Beyer, E.:

»Magnetic pulse welding by electromagnetic compression: Determination of the impact velocity.«

Groche, Peter: Tribology in Manufacturing Processes & Joining by Plastic Deformation: Selected, peer reviewed papers from the 6th International Conference on Tribology in Manufacturing Processes & Joining by Plastic Deformation, ICTMP 2014, June 22-24, 2014, Darmstadt, Germany
Dürnten: Trans Tech Publications, 2014, S.489-499 (Advanced materials research 966-967)
DOI: 10.4028/www.scientific.net/AMR.966-967.489

[L39]

Mahrle, A.; Rose, S.; Beyer, E.; Füssel, U.:

»Crucial role of beam spot position in laser assisted plasma arc welding.«

Science and technology of welding and joining 19 (2014), Nr.2, S.119-124
DOI: 10.1179/1362171813Y.0000000173

[L40]

Mahrle, A.; Rose, S.; Lohse, M.; Beyer, E.; Füssel, U.:

»Interaction mechanism in hybrid laser arc welding.«

Kaierle, S. (Congress General Chair); Laser Institute of America - LIA-: ICALEO 2014, 33rd International Congress on Applications of Lasers & Electro-Optics. Congress proceedings. CD-ROM: October 19-23, 2014, San Diego, CA, USA Orlando, Fla.: LIA, 2014, Paper 1202, 10 S.
DOI: 10.13140/2.1.3470.1769

[L41]

Makowski, S.; Weihnacht, V.; Schaller, F.; Leson, A.:

»Ultra-low friction of biodiesel lubricated ta-C coatings.«

Tribology international 71 (2014), S.120-124
DOI: 10.1016/j.triboint.2013.11.002

[L42]

Materne, E.M.; Wagner, I.; Hasenberger, T.; Lorenz, A.; Schimek, K.; Horland, R.; Hoffmann, S.; Busek, Mathias; Sonntag, Frank; Klotzbach, Udo; Lauster, R.; Marx, U.:

»The multi-organ-chip (MOC) - a universal microfluidic platform for long-term tissue maintenance and substance testing.«

Journal of tissue engineering and regenerative medicine 8 (2014), Supplement 1, S.378-379
DOI: 10.1002/term.1932

[L43]

Meier, A.; Weinberger, M.; Pinkert, K.; Oschatz, M.; Paasch, S.; Giebler, L.; Althues, H.; Brunner, E.; Eckert, J.; Kaskel, S.:

»Silicon oxycarbide-derived carbons from a polyphenylsilsequioxane precursor for supercapacitor applications.«

Microporous and mesoporous materials 188 (2014), S.140-148
DOI: 10.1016/j.micromeso.2013.12.022

[L44]

Nickel, W.; Oschatz, M.; Lehr, M. von der; Leistner, M.; Hao, G.; Adelmüller, P.; Müller, P.; Smarsly, B.; Kaskel, S.:

»Direct synthesis of carbide-derived carbon monoliths with hierarchical pore design by hard-templating.«

Journal of materials chemistry. A, Materials for energy and sustainability 2 (2014), Nr.32, S.12703-12707
DOI: 10.1039/c4ta02260b

[L45]

Niese, S.; Krüger, P.; Kubec, A.; Laas, R.; Gawlitza, P.; Melzer, K.; Braun, S.; Zschech, E.:

»Fabrication of customizable wedged multilayer Laue lenses by adding a stress layer.«

Thin solid films 571 (2014), Nr.2, S.321_DS324
DOI: 10.1016/j.tsf.2014.02.095

[L46]

Niese, S.; Krüger, P.; Kubec, A.; Braun, S.; Patommel, J.; Schroer, C.G.; Leson, A.; Zschech, E.:

»Full-field X-ray microscopy with crossed partial multilayer Laue lenses.«

Optics Express 22 (2014), Nr.17, S.20008-20013
DOI: 10.1364/OE.22.020008

[L47]

Nisato, G.; Klumbies, H.; Fahlteich, J.; Müller-Meskamp, L.; Weijer, P. van de; Bouten, P.; Boeffel, C.; Leuenberger, D.; Grählert, W.; Edge, S.; Cros, S.; Brewer, P.; Kucukpinar, E.; Girolamo, J. de ; Srinivasan, P.:

»Experimental comparison of high-performance water vapor permeation measurement methods.«

Organic Electronics 15 (2014), Nr.12, S.3746-3755
DOI: 10.1016/j.orgel.2014.10.014

- [L48]**
Nowotny, S.; Berger, L.-M.; Spatzier, J.:
»Coatings by laser cladding.«
Sarin, V.K.; Mari, D.: Comprehensive hard materials. Vol.1: Hardmetals
Amsterdam: Elsevier, 2014, S.507-525
DOI: 10.1016/B978-0-08-096527-7.00018-0
- [L49]**
Oschatz, M.; Borchardt, L.; Pinkert, K.; Thieme, S.; Lohe, M.R.; Hoffmann, C.; Benusch, M.; Wisser, F.M.; Ziegler, C.; Giebeler, L.; Rümeli, M.H.; Eckert, J.; Eychmüller, A.; Kaskel, S.:
»Hierarchical carbide-derived carbon foams with advanced mesostructure as a versatile electrochemical energy-storage material.«
Advanced energy materials 4 (2014), Nr.2, Art. 1300645, 9 S.
DOI: 10.1002/aenm.201300645
- [L50]**
Oschatz, M.; Nickel, W.; Thommes, M.; Cychosz, K.A.; Leistner, M.; Adam, M.A.; Mondin, G.; Strubel, P.; Borchardt, L.; Kaskel, S.:
»Evolution of porosity in carbide-derived carbon aerogels.«
Journal of materials chemistry. A, Materials for energy and sustainability 2 (2014), Nr.43, S.18472-18479
DOI: 10.1039/c4ta03401e
- [L51]**
Pap, J.-S.; Jansen, I.; Beyer, E.:
»Strukturelles Kleben von textilverstärkten Thermoplasten mit zäh elastischen Klebstoffen.«
TH Aachen -RWTH-, Institut für Schweißtechnik und Fügetechnik - ISF-: 3. Doktorandenseminar Klebtechnik: Vorträge der gleichnamigen Veranstaltung in Kassel am 5. und 6. November 2012
Düsseldorf: DVS Media, 2014, S.33-39
(DVS-Berichte 303)
- [L52]**
Piccoli, R.; Robin, T.; Méchin, D.; Brand, T.; Klotzbach, U.; Taccheo, S.:
»Effective mitigation of photodarkening in Yb-doped lasers based on Al-silicate using UV/visible light.«
Ramachandran, S.; Society of Photo-Optical Instrumentation Engineers -SPIE-, Bellingham/Wash.: Fiber Lasers XI. Technology, Systems, and Applications: 3 - 6 February 2014, San Francisco, California, United States Bellingham, WA: SPIE, 2014, Paper 896121 (SPIE Proceedings 8961)
DOI: 10.1117/12.2039013
- [L53]**
Piccoli, R.; Robin, T.; Brand, T.; Klotzbach, U.; Taccheo, S.:
»Effective photodarkening suppression in Yb-doped fiber lasers by visible light injection.«
Optics Express 22 (2014), Nr.7, S.7638-7643
DOI: 10.1364/OE.22.007638
- [L54]**
Puschmann, R.; Barbosa, M.M.; Scheitz, S.; Berger, L.-M.; Toma, F.-L.; Leyens, C.; Beyer, E.:
»Technological approach for a full thermally sprayed thermoelectric generator.«
Deutscher Verband für Schweißen und Verwandte Verfahren e. V. -DVS-; The Thermal Spray Society -TSS-; International Institute of Welding -IIW-: ITSC 2014, International Thermal Spray Conference & Exposition: Abstracts (including manuscripts on CD-ROM) of the conference in Barcelona, Spain, on May 21-23, 2014
Düsseldorf: DVS Media, 2014, S.513-518
(DVS-Berichte 302)
- [L55]**
Rauscher, P.; Hauptmann, J.; Wetzig, A.; Beyer, E.:
»Domain refinement of grain oriented electrical steel with high power laser beam sources.«
International journal of modern physics B 28 (2014), Nr.12, Art. 1442003, 11 S.
DOI: 10.1142/S021797921442003X
- [L56]**
Rauscher, P.; Schröder, N.; Hauptmann, J.; Wetzig, A.; Beyer, E.:
»Effects of laser irradiation on the isolation layer of grain oriented electrical steel.«
Schneider, J.; TU Bergakademie Freiberg, Institut für Metallformung; Univ. Gent: 6th International Conference on Magnetism and Metallurgy, WMM 2014: Cardiff, UK, June 17th to 19th, 2014
Cardiff: Spectrum Printing, 2014, S.434-441
- [L57]**
Roch, A.; Stepien, L.; Roch, T.; Dani, I.; Leyens, C.; Jost, O.; Leson, A.:
»Optical absorption spectroscopy and properties of single walled carbon nanotubes at high temperature.«
Synthetic metals 197 (2014), S.182_DS187
DOI: 10.1016/j.synthmet.2014.09.016
- [L58]**
Roch, A.; Roch, T.; Talens, E.; Kaiser, B.; Lasagni, A.F.; Beyer, E.; Jost, O.; Cuniberti, G.; Leson, A.:
»Selective laser treatment and laser patterning of metallic and semiconducting nanotubes in single walled carbon nanotube films.«
Diamond and Related Materials 45 (2014), S.70-75
DOI: 10.1016/j.diamond.2014.03.007
- [L59]**
Roch, A.; Roch Talens, E.; Lehmann, B.; Jost, O.; Leson, A.:
»Synthesis of carbon nanotubes and their relevant properties.«
Fecht, Hans-Jörg (Hrsg.); Brüche, Kai (Hrsg.); Gluche, Peter (Hrsg.): Carbon-based nanomaterials and hybrids: Synthesis, properties, and commercial applications
Hoboken: Pan Stanford Publishing, 2014, S.125-155
- [L60]**
Roch, T.; Klein, F.; Guenther, K.; Roch, A.; Mühl, T.; Lasagni, A.:
»Laser interference induced nanocrystallized surface swellings of amorphous carbon for advanced micro tribology.«
Materials Research Express 1 (2014), Nr.3, Art. 035042, 14 S.
DOI: 10.1088/2053-1591/1/3/035042
- [L61]**
Röling, S.; Braun, S.; Gawlitza, P.; Wöstmann, M.; Ziegler, E.; Zacharias, H.:
»Tunable two-color hard x-ray multilayer Bragg mirrors.«
Optics Letters 39 (2014), Nr.9, S.2782-2785
DOI: 10.1364/OL.39.002782
- [L62]**
Schaaf, P.; Kaspar, J.; Höche, D.:
»Laser gas-assisted nitriding of Ti alloys.«
Hashmi, S.: Comprehensive Materials Processing. Vol.9: Laser Machining and Surface Treatment
Amsterdam: Elsevier, 2014, S.261-278
DOI: 10.1016/B978-0-08-096532-1.00912-2
- [L63]**
Schiefer, T.; Frenzel, R.; Jansen, I.; Calvimontes, A.; Simon, F.:
»Polyelectrolyte adsorption adds to laser pre-treatment.«
Adhesion. Adhesives & sealants 11 (2014), Nr.1, S.38-43
DOI: 10.1365/s35784-014-0264-z
- [L64]**
Schilling, N.; Klotzbach, U.:
»Bearbeitung faserverstärkter Kunststoffe mittels Kurzpuls-Lasersystemen zum selektiven Freilegen von Verstärkungsfasern.«
Innovative Fertigung durch Lasersysteme neuester Generation: Vorträge und Posterbeiträge der 9. Jenaer Lasertagung am 20. und 21. November 2014
Düsseldorf: DVS-Verlag, 2014, S.178-184
(DVS-Berichte 307)
- [L65]**
Schmieder, S.; Sonntag, F.:
»SPR-basierter Mikro-RNA-Nachweis.«
Förster, Andreas: 5. Dresdner Medizintechnik Symposium 2014: Biomedizinische Technik_DS Von der Grundlagenforschung zum Transfer, 01.-03.12.2014, Dresden
Stuttgart: Steinbeis-Edition, 2014, S.89-91 (Reports on Biomedical Engineering 2)

[L66]

Schulze, S.; Göbel, G.; Richter-Trummer, V.; Füssel, U.; Beyer, E.:

»The influence of gaps and misalignment on friction stir welded butt joints of medium-sized parts.«

Mishra, B.; The Minerals, Metals and Materials Society -TMS-, Warrendale/Pa.: THERMEC 2013, 8th International Conference on Processing and Manufacturing of Advanced Materials. Proceedings: December 2 - 6, 2013, Las Vegas, USA Durnten-Zurich: Trans Tech, 2014, S.1788-1793 (Materials Science Forum 783-786)
DOI: 10.4028/www.scientific.net/MSF.783-786.1788

[L67]

Schumm, B.; Kaskel, S.:

»Nanoimprint lithography for photovoltaic applications.«

Tiwari, A.: Solar cell nanotechnology Salem/Mass.: Scrivener Publishing, 2014, S.185-201
DOI: 10.1002/9781118845721.ch7

[L68]

Seifert, M.; Anhalt, K.; Baltruschat, C.; Lenhart-Rydzek, M.; Brenner, B.; Bonß, S.:

»Die Genauigkeit der berührungslosen Temperaturmessung bei der Randschicht-Wärmebehandlung.«

HTM - journal of heat treatment and materials 69 (2014), Nr.3, S.182-191

[L69]

Shilapuram, V.; Ozalp, N.; Oschatz, M.; Borchardt, L.; Kaskel, S.:

»Hydrogen production from catalytic decomposition of methane over ordered mesoporous carbons (CMK-3) and carbide-derived carbon (DUT-19).«

Carbon 67 (2014), S.377-389
DOI: 10.1016/j.carbon.2013.10.008

[L70]

Shilapuram, V.; Ozalp, N.; Oschatz, M.; Borchardt, L.; Kaskel, S.; Lachance, R.:

»Thermogravimetric analysis of activated carbons, ordered mesoporous carbide-derived carbons, and their deactivation kinetics of catalytic methane decomposition.«

Industrial and Engineering Chemistry Research 53 (2014), Nr.5, S.1741-1753
DOI: 10.1021/ie402195q

[L71]

Siebert, R.; Schneider, J.; Beyer, E.:

»Laser cutting and mechanical cutting of electrical steels and its effect on the magnetic properties.«

IEEE transactions on magnetics 50 (2014), Nr.4, Pt.1, Art. 2001904, 4 S.
DOI: 10.1109/TMAG.2013.2285256

[L72]

Siebert, R.; Schneider, J.; Beyer, E.:

»Manufacturing related effects on magnetic properties of electrical steels.«

Schneider, J.; TU Bergakademie Freiberg, Institut für Metallformung; Univ. Gent: 6th International Conference on Magnetism and Metallurgy, WMM 2014: Cardiff, UK, June 17th to 19th, 2014
Cardiff: Spectrum Printing, 2014, S.360-369

[L73]

Slawik, T.; Bergner, A.; Puschmann, R.; Franke, P.; Räthel, J.; Behnisch, T.; Scholl, R.; Berger, L.-M.; Moritz, T.; Zelm, R.; Gude, M.; Michaelis, A.; Beyer, E.; Leyens, C.; Großmann, H.; Kieback, B.:

»Metal_DS ceramic layered materials and composites manufactured using powder techniques.«

Advanced engineering materials 16 (2014), Nr.10, S.1293_DS1302
DOI: 10.1002/adem.201400221

[L74]

Sonntag, F.; Grünzner, S.; Busek, M.; Schmieder, F.; Klotzbach, U.; Franke, V.:

»Multilagenbasierte Lab-on-a-Chip-Systeme für perfundierte, zellbasierte Assays.«

Innovative Fertigung durch Lasersysteme neuester Generation: Vorträge und Posterbeiträge der 9. Jenaer Lasertagung am 20. und 21. November 2014
Düsseldorf: DVS-Verlag, 2014, S.170-177 (DVS-Berichte 307)

[L75]

Toma, F.-L.; Berger, L.-M.; Potthoff, A.; Langner, S.:

»Demands and economic aspects of thermal spraying with suspensions - an overview.«

Deutscher Verband für Schweißen und Verwandte Verfahren e. V. -DVS-; The Thermal Spray Society -TSS-; International Institute of Welding -IIW-: ITSC 2014, International Thermal Spray Conference & Exposition: Abstracts (including manuscripts on CD-ROM) of the conference in Barcelona, Spain, on May 21-23, 2014
Düsseldorf: DVS Media, 2014, S.368-372 (DVS-Berichte 302)

[L76]

Toma, F.-L.; Berger, L.-M.; Kuntze, T.; Scheitz, S.; Thiele, S.:

»Funktionalisierung von Keramikoberflächen durch thermisch gespritzte Schichten.«

Thermal spray bulletin 7 (2014), Nr.1, S.36-42

[L77]

Toma, F.-L.; Berger, L.-M.; Shakhverdova, I.; Leupolt, B.; Potthoff, A.; Oelschlägel, K.; Meißner, T.; Gomez, J.A.I.; Miguel, Y. de:

»Parameters influencing the photocatalytic activity of suspension-sprayed TiO₂ coatings.«

Journal of thermal spray technology 23 (2014), Nr.7, S.1037-1053
DOI: 10.1007/s11666-014-0090-5

[L78]

Trache, R.; Berger, L.-M.; Leyens, C.:

»Comparison of alumina-titania coatings deposited by plasma and HVOF spray techniques.«

Deutscher Verband für Schweißen und Verwandte Verfahren e. V. -DVS-; The Thermal Spray Society -TSS-; International Institute of Welding -IIW-: ITSC 2014, International Thermal Spray Conference & Exposition: Abstracts (including manuscripts on CD-ROM) of the conference in Barcelona, Spain, on May 21-23, 2014
Düsseldorf: DVS Media, 2014, S.824-829 (DVS-Berichte 302)

[L79]

Uhlmann, E.; Stawiszynski, B.; Leyens, C.; Heinze, S.:

»Steigerung der Leistungsfähigkeit von Hartmetallwerkzeugen in der Hartbearbeitung: Anwendung moderner HiPIMS-Schichten beim Hartdrehen.«

Zeitschrift für wirtschaftlichen Fabrikbetrieb: ZWF 109 (2014), Nr.4, S.236-241

[L80]

Wagner, K.; Friedrich, S.; Stang, C.; Bley, T.; Schilling, N.; Bieda, M.; Lagsagni, A.; Boschke, E.:

»Initial phases of microbial biofilm formation on opaque, innovative anti-adhesive surfaces using a modular microfluidic system.«

Engineering in life sciences 14 (2014), Nr.1, S.76-84
DOI: 10.1002/elsc.201200035

[L81]

Walter, J.; Hennings, C.; Hustedt, M.; Kaierle, S.; Borkmann, M.; Mahrle, A.:

»Effizienzsteigerung beim Remote-Laserschweißen durch optimierte Luftströmungsführung.«

Ruck, B. (Hrsg.); Deutsche Gesellschaft für Laser-Anemometrie e. V. -GALA-: 22. Fachtagung "Lasermethoden in der Strömungstechnik" 2014 : Karlsruhe, 9.-11.9.2014
Karlsruhe: GALA, 2014, S.49/1-49/8
URL: <http://www.galaev.org/images/Beitraege/Beitraege%202014/pdf/49.pdf>

[L82]

Wank, A.; Beck, F.; Schläfer, T.; Nowotny, S.; Brückner, F.; Hillig, H.; Pfennig, M.; Thieme, S.:

»Capability of combined thermal spray and laser coating centers to improve production efficiency.«

Welding and cutting 13 (2014), Nr.2, S.100-102

[L83]

Wehnert, F.; Langer, M.; Kaspar, J.; Jansen, I.:

»The contribution of nanoparticles towards multifunctionality within adhesives.«

10th European Adhesion Conference, EURADH 2014: Alicante/Spain (22.-25.4.2014)
Alicante: Sociedad de Adhesión, 2014, S.63-67

[L84]

Wisser, F.M.; Eckhardt, K.; Wisser, D.; Böhlmann, W.; Grothe, J.; Brunner, E.; Kaskel, S.:

»Tailoring pore structure and properties of functionalized porous polymers by cyclotrimerization.«

Macromolecules 47 (2014), Nr.13, S.4210-4216
DOI: 10.1021/ma500512j

[L85]

Wollmann, P.:

»Spektroskopie in neuen Dimensionen: Hyperspectral Imaging in Labor und Prozessanwendungen.«

Polytec Info. Informationszeitschrift aus dem Hause Polytec 76 (2014), S.20-22

[L86]

Ylivaara, O.M.E.; Liu, X.; Kilpi, L.; Lyytinen, J.; Schneider, D.; Laitinen, M.; Julin, J.; Ali, S.; Sintonen, S.; Berdova, M.; Haimi, E.; Sajavaara, T.; Ronkainen, H.; Lipsanen, H.; Koskinen, J.; Hannula, S.-P.; Puurunen, R.L.:

»Aluminum oxide from trimethylaluminum and water by atomic layer deposition: The temperature dependence of residual stress, elastic modulus, hardness and adhesion.«

Thin solid films 552 (2014), S.124-135
DOI: 10.1016/j.tsf.2013.11.112

[L87]

Zimmermann, M.; Kolyshkin, A.; Stöcker, C.; Jones, J.W.; Christ, H.-J.:

»Damage evolution and crack growth in nickel-based alloys during ultrasonic fatigue.«

Mishra, B.; The Minerals, Metals and Materials Society -TMS-, Warrendale/Pa.: THERMEC 2013, 8th International Conference on Processing and Manufacturing of Advanced Materials. Proceedings: December 2 - 6, 2013, Las Vegas, USA
Durnten-Zurich: Trans Tech, 2014, S.2410-2415 (Materials Science Forum 783-786)
DOI: 10.4028/www.scientific.net/MSF.783-786.2410

[L88]

Zimmermann, M.; Bretschneider, J.; Kirchhoff, G.; Stamm, U.; Standfuss, J.; Brenner, B.:

»Fatigue behaviour of laser beam welded circular weld seams under multi-axial loading.«

Clark, G.: Fatigue 2014, 11th International Fatigue Congress. Pt.2: Selected, peer reviewed papers from the 11th International Fatigue Congress 2014, March 2-7, 2014, Melbourne, Australia
Durnten-Zurich: TTP, 2014, S.1397-1402
(Advanced materials research 891-892)
DOI: 10.4028/www.scientific.net/AMR.891-892.1397

[L89]

Ziolkowski, G.; Chlebus, E.; Szymczyk, P.; Kurzac, J.:

»Application of X-ray CT method for discontinuity and porosity detection in 316L stainless steel parts produced with SLM technology.«

Archives of civil and mechanical engineering 14 (2014), Nr.4, S.608-614
DOI: 10.1016/j.acme.2014.02.003

ADDRESS AND DIRECTIONS

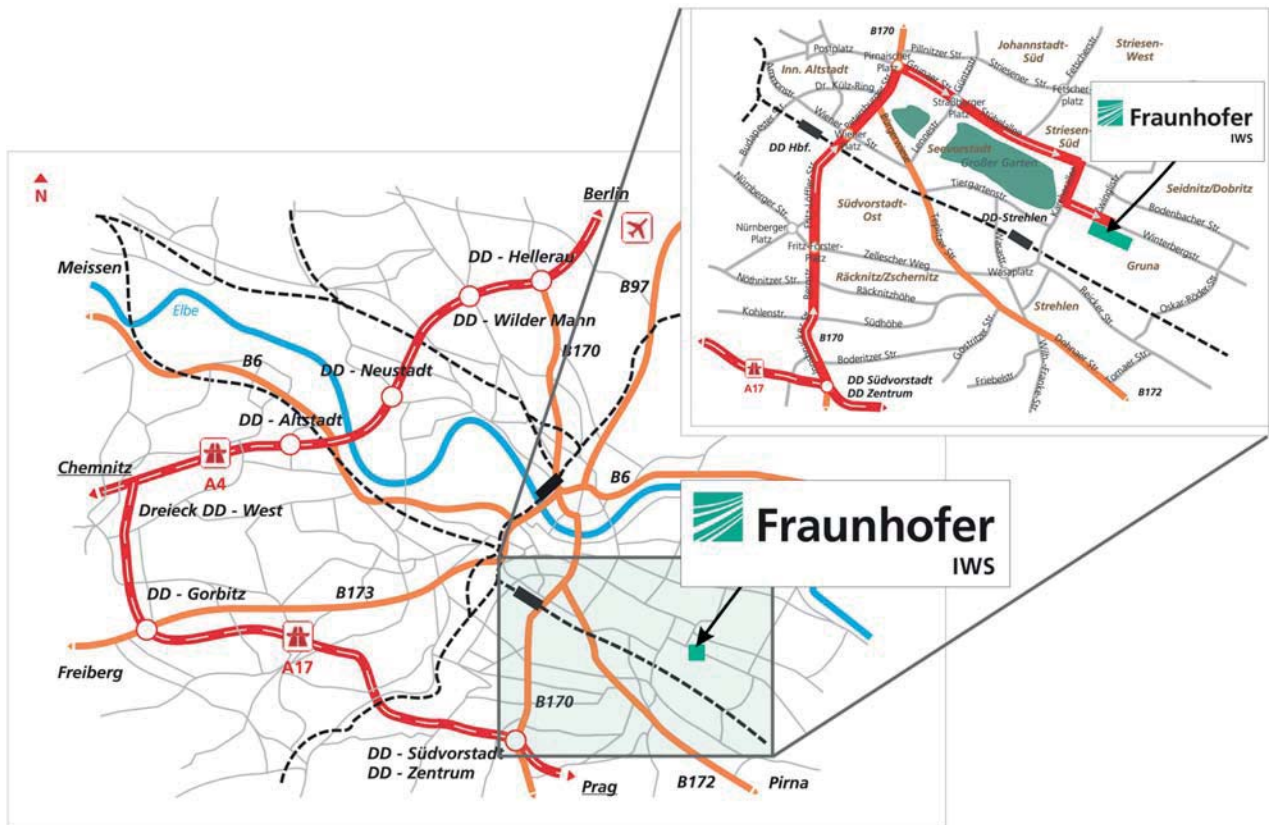

by car (from Autobahn / highway)

- take Autobahn A4 or A13 to intersection Dresden-West, follow new Autobahn A17 to exit Südvorstadt / Zentrum
- follow road B170 in direction Stadtzentrum (city center) to Pirnaischer Platz (about 6 km)
- at Pirnaischer Platz turn right towards "Gruna / VW-Manufaktur"
- continue straight until the end of the "Großer Garten" (Great Garden) and then turn right onto Karcherallee
- at the next traffic light turn left onto Winterbergstraße and continue straight until IWS

by railway and tram

- from Dresden main railway station take line #10 to Straßburger Platz
- change to line #1 (Prohlis) or #2 (Kleinzschachwitz) heading out from the city; exit at Zwinglistraße stop
- 10 minutes to walk from there (in the direction of Grunaer Weg)

by air plane

- from Airport Dresden-Klotzsche with a taxi to Winterbergstraße 28 (about 10 km)
- or with public transportation (shuttle train) to the main railway station (Hauptbahnhof), and continue with the tram

Address:

Fraunhofer-Institut für Werkstoff- und Strahltechnik IWS Dresden
(Fraunhofer Institute for Material and Beam Technology)

Winterbergstraße 28
01277 Dresden

Internet address:

www.iws.fraunhofer.de

phone +49 351 83391-0
fax +49 351 83391-3300
e-Mail info@iws.fraunhofer.de

Editorial staff:	Dr. Anja Techel	
Coordination:	Dipl.-Kffr. Anne Kutzleb	
	Dr. Ralf Jäckel	
Editing:	Georg Techel	
	René Zenner	
English edition:	Kathleen Schuelke	
	Claudia Leson	
Photos:	p. 2	Prof. Beyer (private) / Jürgen Jeibmann
	p. 5, 10, 13, 48, 90	Frank Höhler
	p. 8 (Fig. 1 left, middle)	DMG Mori Seiki AG
	p. 8 (Fig. 1 right)	Alpha Laser GmbH
	p. 6	Joachim Blobel
	p. 9 (top)	Held Systems GmbH
	p. 9 (bottom)	GTV Verschleißschutz GmbH
	p. 11	Dr. Junker (private)
	p. 14, 20, 22, 42, 44, 49, 56, 58, 68, 70, 73, 77, 88, 97, 106, 108, 139	Jürgen Jeibmann
	p. 18, 54	Fraunhofer IWS / Jürgen Jeibmann
	p. 30	MEV Verlag GmbH / Fraunhofer IWS Dresden
	p. 33, 146	TU Dresden
	p. 51	Firma DOT Rostock
	p. 55 (Fig. 3)	TU Wrocław
	p. 55 (Fig. 4)	Siemens AG
	p. 75	Keyence Corporation
	p. 83	TU Dresden / Fraunhofer IWS
	p. 86, 87	Fraunhofer USA
	p. 87	Trumpf
	p. 96, 97	Mackinac Technology Company
	p. 122	James Thew, Fotolia.com
	p. 142	adimas, Fotolia.com
	p. 151	DDpix.de, Marcel Quietzsch
	all other pictures	Fraunhofer IWS

© Fraunhofer Institute for Material and Beam Technology IWS Dresden 2015

Reprints require permission of the editor.